

STANDARD SPECIFICATIONS AND
DRAWINGS
for
WATER SYSTEMS

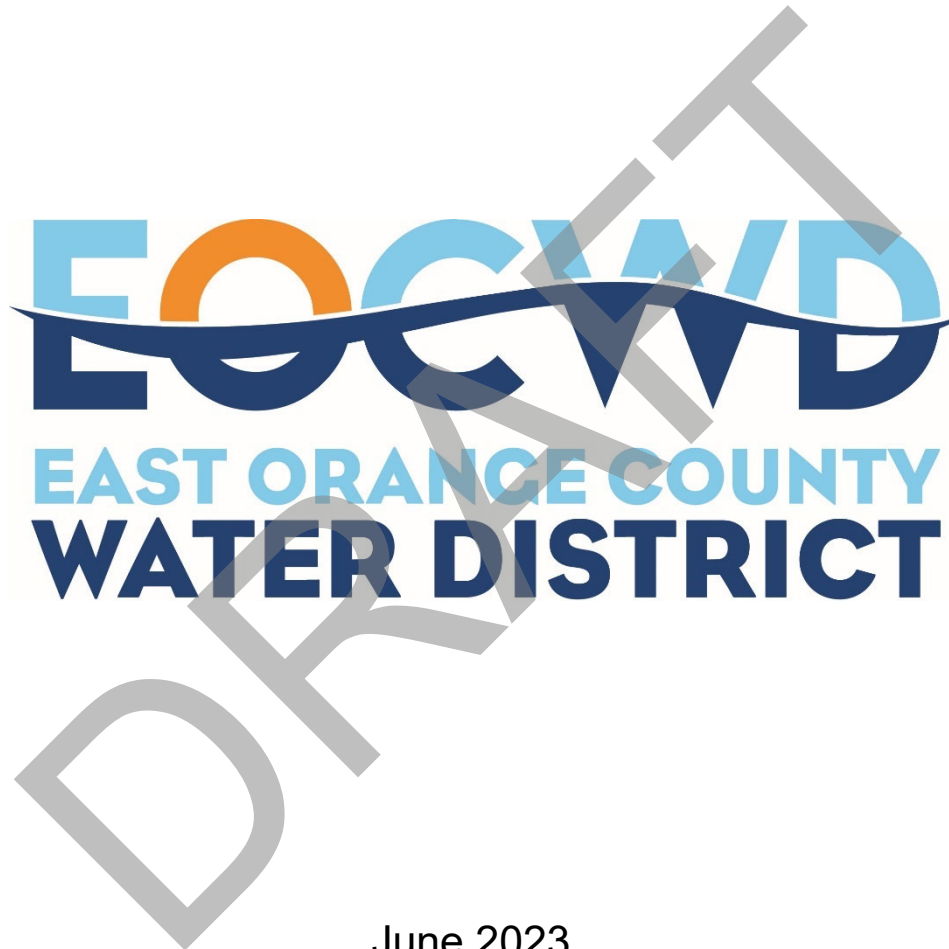

June 2023

1. STANDARD SPECIFICATIONS FOR WATER SYSTEMS

Table of Contents

- 1. STANDARD SPECIFICATIONS for WATER SYSTEMS 1-i**
- 1.1 **DEFINITIONS AND ABBREVIATIONS 1-1**
- 1.2 **INSTRUCTIONS TO DEVELOPERS, ENGINEERS, AND HOMEOWNERS 1-3**
 - 1.2.1 **AUTHORITY 1-3**
 - 1.2.2 **PERMITS 1-3**
 - 1.2.3 **PLAN CHECKING, APPROVALS, AND FEES 1-3**
 - 1.2.4 **AUTHORIZATION 1-4**
 - 1.2.5 **CONNECTION FEES AND OTHER FEES 1-4**
 - 1.2.6 **INDEMNITY BOND 1-4**
 - 1.2.7 **IMPROVEMENT BONDS 1-4**
 - 1.2.8 **BOND RELEASE 1-4**
 - 1.2.9 **PROVIDING REQUIRED EASEMENTS 1-4**
- 1.3 **INSTRUCTIONS TO DESIGNERS 1-5**
 - 1.3.1 **GENERAL 1-5**
 - 1.3.2 **PLANS 1-5**
- 1.4 **STEPS TO PROCURE WATER SERVICE FROM THE DISTRICT 1-7**
 - 1.4.1 **AVAILABILITY OF SERVICE 1-7**
 - 1.4.2 **PRELIMINARY FEASIBILITY INVESTIGATION 1-7**
 - 1.4.3 **RESPONSIBILITY FOR FURNISHING MATERIAL AND INSTALLATION 1-7**
 - 1.4.4 **GUARANTEES 1-7**
 - 1.4.5 **DEDICATIONS OF FACILITIES 1-7**
 - 1.4.6 **AGREEMENT FOR INSTALLATION OF WATER FACILITIES 1-8**
- 1.5 **DESIGN 1-8**
 - 1.5.1 **PROVIDING REQUIRED EASEMENT 1-8**
 - 1.5.2 **DISTRICT’S REGULATION REGARDING CROSS CONNECTIONS 1-8**
 - 1.5.3 **MINIMUM SIZE 1-9**
 - 1.5.4 **TYPE OF MAIN PIPE 1-9**
 - 1.5.5 **MINIMUM DEPTH TO TOP OF WATER MAIN PIPE 1-9**
 - 1.5.6 **MAXIMUM DEPTH TO TOP OF MAIN PIPE 1-9**
 - 1.5.7 **STANDARD LOCATION 1-9**
 - 1.5.8 **WATER VALVE SPACING 1-10**
 - 1.5.9 **NORMAL SYSTEM AND FIRE FLOW DEMANDS 1-10**
 - 1.5.10 **FIRE HYDRANT SPACING 1-10**
 - 1.5.11 **SERVICE MATERIALS AND MINIMUM SERVICE SIZE 1-11**
 - 1.5.12 **MISCELLANEOUS STANDARD GUIDELINES 1-11**
- 1.6 **SEPARATION OF WATER, SEWER, AND RECLAIMED WATER LINES 1-12**
- 1.7 **FIREFLOW LIABILITY 1-12**
- 2. General Conditions for Construction and Inspection of Facilities 2-1**
- 2.1 **SCOPE AND CONTROL OF WORK 2-1**

2.1.1	RESPONSIBILITY FOR FURNISHING MATERIAL AND INSTALLATION	2-1
2.1.2	GUARANTEES	2-1
2.1.3	LICENSES	2-1
2.1.4	PERMITS	2-2
2.1.5	PLANS AND SPECIFICATIONS	2-2
2.1.6	WORK TO BE DONE	2-3
2.1.7	RIGHT-OF-WAY	2-3
2.2	<u>CONTROL OF MATERIALS</u>	2-3
2.2.1	MATERIALS AND WORKSMANSHIP	2-3
2.3	<u>UTILITIES</u>	2-4
2.3.1	LOCATION.....	2-4
2.3.2	PROTECTION.....	2-4
2.4	<u>RESPONSIBILITIES OF CONTRACTOR IN CONDUCT OF WORK</u>	2-5
2.4.1	CONSTRUCTION SCHEDULE AND OF WORK	2-5
2.4.2	PUBLIC CONVENIENCE AND SAFETY.....	2-5
2.4.3	NO PERSONAL LIABILITY.....	2-5
2.4.4	RESPONSIBILITY FOR DAMAGE.....	2-5
2.4.5	LEGAL RELATIONS AND RESPONSIBILITY.....	2-6
2.4.6	INSURANCE.....	2-6
2.4.7	STORAGE OF EQUIPMENT AND MATERIALS IN PUBLIC STREETS	2-6
2.4.8	STREET CLOSURES, DETOURS AND BARRICADES	2-6
2.4.9	SAFETY	2-7
2.5	<u>INSPECTION PROCEDURES</u>	2-8
2.5.1	NOTICE OF STARTING CONSIDERATION.....	2-8
2.5.2	HOURS OF INSPECTION	2-8
2.5.3	INSPECTION OF WORK.....	2-9
2.5.4	DISTRICT AUTHORITY	2-9
2.5.5	PLACING PORTIONS OF WATER MAINS IN SERVICE EARLY	2-10
2.5.6	FINAL WATER FACILITIES INSPECTION	2-10
2.5.7	INTERPRETATION OF SPECIFICATIONS AND DETAIL DRAWINGS	2-10
2.5.8	RELEASE GIVEN TO COUNTY	2-11
3.	<i>Domestic Water Systems Specifications</i>	3-1
4.	<i>Standard Drawings for Water Systems</i>	4-1

1.1 DEFINITIONS AND ABBREVIATIONS

Applicant (Or Developer) – The owner requesting the installation or construction of water facilities for integration with the District’s existing boundary.

Approved Equal – A material or product that exceeds or is equivalent to, in the opinion of the District Engineer, in all respects, that which is specified herein.

Approved Plans – Construction plans as specified herein approved by the East Orange County Water District attested to by the District Engineer’s signature.

ANSI – The American National Standards Institute. All references to the specifications of the ANSI are understood to refer to the current editions as revised and/or amended at the date of construction.

ASTM – The American Society for Testing Materials. All references to the specifications of the ASTM are understood to refer to the current editions as revised and/or amended at the date of construction.

AWWA – The American Water Works Association, Inc. All references to the specifications of the AWWA are understood to refer to the current editions as revised and/or amended at the date of construction.

Contractor – The persons, firm, or corporation entering into contract with the Owner or Developer for the performance of Work required under said contract, the District ordinances and these requirements.

Commercial Development – Applies to any other construction or development that is neither Residential Development nor Single Family Residence.

Design Engineer – A private Professional Engineer hired by the Owner or Developer for the design of the proposed Work.

District – East Orange County Water District.

District General Manager – Person holding the position or acting in the capacity of the General Manager of the District.

District Engineer – The District Engineer of the East Orange County Water District or duly authorized agent of the District Engineer.

District Representative (Inspector) – The person authorized by the District to perform all inspection duties called for by these specifications. The representatives may vary during the duration of the project.

Fire Marshal – The person authorized to approve fire flow, hydrant spacing, and other fire related criteria.

Final Acceptance – The formal action by the District accepting the Work as fully completed, in accordance with these requirements.

Offsite Facilities – Facilities under the control of the District including but not limited to waterlines, reservoirs, pumping stations, fire hydrants, vaults, valves, connections, supply interties, treatment facilities, and other appurtenances and property up to the point of connection with the customer's facilities. Offsite facilities include all District facilities within public streets and easements.

Onsite Facilities – Facilities under the control of the Applicant, owner, or customer including but not limited to residential, commercial, and industrial building water. For water, the onsite facilities shall be those downstream of the service connection, which shall normally be the downstream end of the meter tailpiece.

OSHA – Code of Federal Regulations, Title 29, Part 1910, U.S. OSHA, and State of California, Code of Regulations, Title 8, Construction Safety Orders.

Owner or Developer – The property owner/person requesting the installation or construction of water facilities within the District's service boundary.

Plans – Part of the Approved Plans and specifications which consist of the plans, profiles, typical cross-sections and working drawings or exact reproductions thereof which show the location, character, dimensions, and details of the Work to be done.

Residential Development – Any development consisting of multiple residences.

Single-Family Residential – Any residence involving only one dwelling unit per building site not withstanding an accessory dwelling unit.

Standard Drawings – Part of these requirements titled, "Standard Drawings".

Standard Specifications for Public Works Construction (SSPWC) – The Standard Specifications for Public Works Construction, Green Book, latest edition.

State Specification – The Standard Specifications, State of California, Department of Transportation (Caltrans), latest edition.

Water System – Potable or drinking water system.

Work – All the work specified in the standard requirements, plans, and standard drawings necessary to complete the construction of water systems.

1.2 INSTRUCTIONS TO DEVELOPERS, ENGINEERS, AND HOMEOWNERS

1.2.1 AUTHORITY

The Work shall be completed in accordance with the latest editions of the District’s standards, SSPWC, State Specifications, and all other applicable codes and standards. The District’s standards shall govern above others for water design and installation purposes, unless otherwise stated. Standards from any agency having jurisdiction shall govern for work required, as approved by the District.

Prior to the preparation of any plans, specifications or descriptions, the Developer (or the Developer’s engineer) shall meet with District staff to determine the extent of the District’s requirements for providing service to the development by the District.

1.2.2 PERMITS

No work shall be started until the Contractor has obtained all necessary permits. The Contractor shall obtain all permits and give all notices necessary and incidental to the due and lawful execution of the Work, and to the preservation of the public health and safety. The District will issue a permit for the Work to be done in addition to District facilities. The Contractor shall obtain and pay for all permits required by other agencies having jurisdiction over the Work.

1.2.3 PLAN CHECKING, APPROVALS, AND FEES

Prior to the construction of any water facilities for the District (or facilities to become the property of the District), construction drawings for the subject Work shall require approval by the District Engineer and shall be stamped and signed by the Design Engineer preparing the Plans.

Approval by the District Engineer on drawings for facilities to become the property of the District shall apply only to general design concepts with respect to the District’s master planned capacity, maintenance procedures, and quality of materials. This will signify approval for a permit for construction but will not guarantee the absence of errors and omissions.

When plan checking by the District is necessary, a plan check deposit fee per the District’s current fee schedule shall be deposited. The first plan check fee may be waived at the District’s discretion. The cost for fire flow analysis, if required or requested, shall be borne by the Developer or Owner.

System capacity analyses are required for residential and commercial development projects to ensure adequate flow capacity for the new development. The cost of the analysis will be borne by the Developer.

New connections to the public water system have an inspection fee per the District’s fee schedule.

1.2.4 AUTHORIZATION

Upon receipt of the preliminary deposit, the District Engineer will proceed with the plan checking.

1.2.5 CONNECTION FEES AND OTHER FEES

From the tract or parcel map submitted, the required water connection fees and any other inspection and engineering fees based on the then governing Schedule of Rates and Charges adopted by the District's Board of Directors will be applied. The Developer will then be notified of these charges.

1.2.6 INDEMNITY BOND

If water facilities are to be constructed in a right-of-way under the jurisdiction of an agency requiring the District to sign the encroachment permit, the Applicant shall furnish the District with an indemnity bond satisfactory to the District prior to execution of the application.

1.2.7 IMPROVEMENT BONDS

The Developer shall post improvement bonds with either the County of Orange or directly with the District prior to construction of the water system. The bonds shall guarantee the satisfactory completion of the water system in the sole opinion of the District.

1.2.8 BOND RELEASE

Subject to Government Code Section 66499.7, including all rights and notices contained and required therein, the District shall release the bonds or other security furnished by the Developer in connection with the required work upon acceptance of such work by the District.

1.2.9 PROVIDING REQUIRED EASEMENTS

Permanent easements, where absolutely necessary, shall be a minimum of 10 feet in width and shall be shown on the plans. Temporary easements for construction only shall be shown on the plans including date of termination.

Where applicable, permanent easements shall be recorded on the tract map, and granted to the East Orange County Water District. When applicable, separate easement documents for both permanent and temporary easements shall be prepared and presented to the District for acceptance and recording.

1.3 INSTRUCTIONS TO DESIGNERS

1.3.1 GENERAL

DISTRICT TO APPROVE ALL WATER DESIGNS FOR NEW DEVELOPMENT

- 1) Master Water Development Plan - Two sets of the tentative master water development plans and one electronic copy are to be submitted to the District Engineer by the Developer or the Developer's Engineer at least 30 days before any planned tract or parcel map filing. The initial plan checking and inspection deposit as previously outlined shall accompany this submittal.
- 2) Water System Design Approval - The District Engineer will approve the water system for the tentatively planned development, taking into consideration the following:
 - a) Existing transmission main locations and sizes.
 - b) Fire flow requirements. Fire flow costs will be borne by the Developer.
 - c) District's Water Master Plan where applicable (The Water Master Plan may not reference the specific development being reviewed unless it had come to the District's attention prior to the preparation of the Master Plan. It should also be noted that the 8-inch minimum operational line sizing criteria set forth in Section E-I of these Standard Specifications takes precedence over smaller line sizing which may be indicated in the Master Plan as hydraulically adequate).
 - d) District's design criteria.

When the District Engineer reviews the tentative water system plan, the final sizing and required system looping will be determined and specified by the Design Engineer and approved by the District. Improvements will be incorporated into a future updated Master Plan.

Upon receiving a tentative approval from the governing fire department for hydrant spacing and main sizing for fire flows, the District Engineer will send a copy of the preliminary water design to the Developer's Engineer with corrections and comments noted. Fire Marshal's approval shall be coordinated by the Developer.

1.3.2 PLANS

1 COVER SHEET

The cover sheet shall be the East Orange County Water District standard sheet. A standard blank cover sheet template will be provided upon request by the District, and include at a minimum the following:

- As a minimum, the cover sheet will delineate:
 - Vicinity Map (General Orange County).
 - Location Map and Sheet Index Map (Specific location).

- Name of project including contract number, title, and District number.
- Approval blocks for signature of all agencies required, in addition to the signature block of the Design Engineer preparing the plans and the General Manager and District Engineer's approval block.
- General notes which describe Work to be done in summary terms.
- In lieu of that shown (and when applicable), a separate survey control sheet shall be prepared delineating horizontal and vertical survey control, benchmarks, abbreviations, legend delineations and other applicable data which may be included thereon.

2 PLAN AND PROFILE

- All Work shall be shown and delineated in accordance with the applicable industry standards.
 - Scale shall be 1" = 40' (horizontal), and 1" = 4' (vertical). Any other scale shall receive pre-approval from the Engineer.
 - Construction notes, station numbers, and quantities shall be used and all applicable notes of construction shall be called out.
 - Typical section, hydraulic data, and benchmark data shall be shown.
- Soil boring information shall be shown and shall reference the boring report, including the date the boring was performed and the name of the geotechnical firm.
- Utility locations shall be shown as accurately as possible in both plan and profile in accordance with standard practice for underground utility plans delineations per ASCE/CI 38-02.

3 DETAILS

Applicable detail sheets shall be prepared and shall show all necessary details for construction survey controls.

4 SIZE OF PLANS

All plans shall be 24 x 36 inches in size.

5 FINAL APPROVAL

The plans shall be signed by a Civil Engineer Registered in the State of California, under whose jurisdiction the plans were prepared. When final approval for a permit is issued by the District, the Design Engineer and internal District Engineer's signature will be shown. Infrastructure that will be transferred to the District requires the District Engineer's

approval.

1.4 STEPS TO PROCURE WATER SERVICE FROM THE DISTRICT

1.4.1 AVAILABILITY OF SERVICE

The following is the procedure for an owner, Developer, or Design Engineer to obtain approval for construction of water facilities to be dedicated for operation and maintenance to the District. The Developer (Applicant) shall check with the District to determine the current boundaries of the water service areas and the availability of service.

1.4.2 PRELIMINARY FEASIBILITY INVESTIGATION

In some areas, a feasibility investigation and report may be necessary to establish whether and how the District can serve the proposed area. An agreement whereby the Developer shall advance the estimated cost to the District for making any feasibility study shall be executed and money deposited if deemed necessary by the District.

1.4.3 RESPONSIBILITY FOR FURNISHING MATERIAL AND INSTALLATION

Prior Installation of a development's water facilities and any other required offsite facilities as required by the District will be the obligation of the Developer at their expense. The Developer shall cause all installation work to meet the District's Standard Specifications; and upon final acceptance, convey the facilities to the District.

1.4.4 GUARANTEES

The Developer shall be responsible for all repairs and replacements for a period of one year from the date of acceptance without expense whatsoever to the District, ordinary wear and tear and unusual abuse or neglect excepted. In the event of failure to comply with the aforementioned conditions, the District is authorized to proceed to have the defects repaired and made good at the expense of the Developer, who is or who will be responsible for costs and charges, including attorney fees and other incidental costs involved thereof, immediately upon demand.

1.4.5 DEDICATIONS OF FACILITIES

The Developer shall furnish the District record drawings, 1 digital copy and 1 hard copy, of the facilities. Upon completion, final inspection, and record drawing submission for all work, the Developer shall file a request at least 30 days prior to a regular Board of Directors meeting for dedication and formal acceptances. Upon said acceptance, the District will give approval for the release of bonds posted to the city or county for the construction of water facilities subject to Government Code Section 664997.

1.4.6 AGREEMENT FOR INSTALLATION OF WATER FACILITIES

Prior to the approval of plans, the Developer shall enter into an Agreement for Installation of Water Facilities.

1.5 DESIGN

1.5.1 PROVIDING REQUIRED EASEMENT

From the tract or parcel map submitted, the District will compute the required water connection fees and any other inspection and engineering fees based on the most current governing Schedule of Rates and Charges adopted by the District's Board of Directors. The Developer will then be notified of these charges.

1.5.2 DISTRICT'S REGULATION REGARDING CROSS CONNECTIONS

All potable water services shall be subject to the provisions of the Orange County Health Care Agency's Rules and Regulations on Water Backflow Prevention. The following summarizes these provisions:

Cross connections of any type that permit a backflow condition from any source or system are prohibited, unless that of the District's potable water mains. A connection constituting a potential or actual backflow hazard is not permissible unless a backflow device or air gap, which is specified on the List of Approved Backflow Prevention Assemblies published by the Foundation for Cross-Connection Control and Hydraulic Research, a Division of the University of Southern California, is installed. Such an installation shall always be subject to inspection and regulation by the District for the purpose of avoiding the possibility of backflow.

The District will not provide any water service to any premises or continue to serve water unless the public water supply is protected as required by state, county, and District regulations.

New and/or replacement backflow prevention devices shall be approved by the District prior to installation. Backflow prevention devices shall be installed at the expense of the customer.

Backflow devices are required to be tested annually. New devices, replacement devices, or repaired devices must be tested upon installation or repair. The customer shall service such devices to maintain them in satisfactory operating condition and shall overhaul or replace such devices if they are found defective.

Records of such annual tests, repairs, retests after repairs or replacement, and overhauling shall be kept by the customer and copies forwarded to the District and local Health Agency.

Water service to any premises may be discontinued by the District if the required backflow prevention device is not installed, tested, and maintained resulting in a potential cross

connection as determined by the District. Water service to any premises may also be discontinued by the District if any defect is found in an installed backflow prevention device; or if it is found that a backflow prevention device has been removed or bypassed; or if unprotected cross connections exist on the premises. Service will not be restored until such conditions or defects are corrected.

Additional reference for guidelines to when, why, and what types of backflow and cross-connection control devices are approved may be found in:

- 1) Regulations Relating to Cross-Connections, California Administrative Code - Title 17 - Public Health
- 2) Cross-Connection Control Policy Handbook by the California State Water Resources Control Board

1.5.3 MINIMUM SIZE

The normal minimum size distribution main shall be 8-inch and shall be looped, unless otherwise determined by the District Engineer. On dead-end streets, the minimum size main shall be 8 inches to at least the last fire hydrant. In some cases, this minimum size criteria may conflict with pipe sizing noted in the District's Master Plan or in other reports prepared by or for the District. In such cases, the minimum sizing criteria set forth in this section shall take precedence over the other plans or reports. Any deviations shall require the approval of the District Engineer. All line sizing to be based on peak day demand plus fire flow.

1.5.4 TYPE OF MAIN PIPE

Only PVC pipe or Ductile-Iron pipe meeting these specifications shall be used for distribution or transmission mains within the District. Steel pipe shall only be used upon the approval of the District. Specifications for these materials are included in Part 3.

1.5.5 MINIMUM DEPTH TO TOP OF WATER MAIN PIPE

The top of the pipe is to be a minimum of 42 inches for pipeline up to 10 inch in diameter and 48 inches for pipeline larger than 10 inch in diameter below the street subgrade unless indicated otherwise on job plans or directed otherwise by the District Engineer or other public representative who has jurisdiction because of unusual field conditions.

1.5.6 MAXIMUM DEPTH TO TOP OF MAIN PIPE

Any existing or new pipe should be no deeper than 5 feet and must be approved by the District.

1.5.7 STANDARD LOCATION

Domestic water mains shall normally be located 6 feet from the curb face. Curbs shall be installed in tracts prior to beginning construction of the water facilities. All water line improvements shall be extended to the far end of the tract or parcel being developed, unless otherwise approved by the District.

1.5.8 WATER VALVE SPACING

Generally, there should be three control valves at all tees and four control valves at all crosses. Push-on connections are not allowed for tees or cross connections. Valves must be connected directly by way of flange connection. Any deviation requires District Engineer approval.

On long blocks, intermediate valves should be installed so that only a maximum of 28 lots or 600 feet, whichever is less, would have to be shut off at any one time.

Valves should also be spaced so that not more than two fire hydrants should be out of service at any one time.

In most cases where water mains pass through easements outside traveled streets, a valve shall be located at each end of the easement. Valve locations shall be determined by the District Engineer.

1.5.9 NORMAL SYSTEM AND FIRE FLOW DEMANDS

Water System Design - The water system shall be designed based on the following:

System Demand	Description
Domestic (3-5 persons per dwelling unit)	
Average	250 gpd per capita
Peak Day	185% of average daily demand
Peak Hour	400% of average daily demand
Commercial	2.5 gpm/acre
Parks	15.0 gpm/acre
Fire	Flow as required by the Fire Marshal
NOTE: All line sizing is based on peak day demand plus fire flow	

All line sizing is based on maximum day demand plus fire flow. Final pipeline sizing must be approved by the District. The design criteria to be used for determining fire flow requirements shall be as established by the Fire Department of jurisdiction.

1.5.10 FIRE HYDRANT SPACING

Fire hydrant spacing shall be approved by the Fire Department of jurisdiction prior to District acceptance of plans. Private onsite fire hydrants may be permitted but the owner shall maintain responsibility for the hydrant and detector check assembly.

Residential area fire hydrants shall be 325 to 400 feet apart, but no more than 120,000 square feet per hydrant. Industrial area fire hydrants shall be 280 to 320 feet apart, but no more than 90,000 square feet per hydrant. Private onsite fire hydrants are not permitted. No more than one fire hydrant shall be located on a dead-end line. Actual spacing is

established and must be approved by the Fire Marshal prior to District acceptance of the plans.

1.5.11 SERVICE MATERIALS AND MINIMUM SERVICE SIZE

1 GENERAL

Approved manufacturers for various service materials and connections are listed in Part III, "Domestic Water System Specifications," herein.

2 MINIMUM DOMESTIC SERVICE SIZE

If pressure-reducing valves are required, the minimum service line shall be 1-inch with 3/4-inch meter. The sizing of the service shall be specified on the plans designated by lot numbers. Commercial or industrial developments are to be as shown on plans or as directed by District Engineer.

NOTE: For industrial, commercial, private street in residential, and other non-residential development, the District will require a detail on the plans of the location of the proposed service.

3 METERS

All residential, industrial, and commercial meters and meter boxes will be furnished and installed by the District, after payment of all applicable charges including costs of meters and meter boxes. All meters will be furnished and installed by the District. Meter boxes may be installed by others with District approval.

1.5.12 MISCELLANEOUS STANDARD GUIDELINES

The following lists miscellaneous standard guidelines:

- 1) Quantity estimates to be included on the plans indicating quantity of pipe, valves, fire hydrants, and domestic services, etc.
- 2) The drawing shall show on plan and profile the position, size, station numbers (as applies), and description of all other known underground utilities or proposed underground utilities.
- 3) Blowoffs shall be installed at the end of main and low points where either the flow velocity or the slope of the line may cause sediment to settle on the end of the line.
- 4) Air and vacuum valves to be installed at all high points in the line as directed by the District Engineer.

1.6 SEPARATION OF WATER, SEWER, AND RECLAIMED WATER LINES

Separation between water, sewer, and recycled waterlines shall conform to the State of California Department of Health Services Guideline Title 22, Sections 64572 and as modified in these specifications and the District Standard Drawings.

1.7 FIREFLOW LIABILITY

Nothing contained in these Standard Specifications shall be construed as a representation or guarantee by the District that any fire flow or pressure will be supplied, therefore, the District assumes no responsibility.

DRAFT

2. GENERAL CONDITIONS FOR CONSTRUCTION AND INSPECTION OF FACILITIES

2.1 SCOPE AND CONTROL OF WORK

2.1.1 RESPONSIBILITY FOR FURNISHING MATERIAL AND INSTALLATION

It is the Developer's responsibility to provide all materials, labor and equipment needed to construct the work in accordance with these Standard Specifications.

Whenever something is said to be the responsibility of the Contractor, the Developer or Owner shall not be thereby relieved of any responsibility. It is not intended that there be a contractual relationship between the District and the Contractor.

2.1.2 GUARANTEES

Besides guarantees required elsewhere, if any, the Contractor shall and hereby does guarantee the work for a period of one year after the date of acceptance of the work by the District. The Contractor shall repair or remove and replace any and all work, together with any other work which may be displaced in so doing, that is found to be defective in workmanship and/or materials within said one-year period, without expense whatsoever to the District, ordinary wear and tear and unusual abuse or neglect excepted. In the event of failure to comply with the above-mentioned conditions within one week after being notified in writing, the District is hereby authorized to proceed to have the defects remedied at the expense of the Contractor, who hereby agrees to pay the cost and charges therefore immediately on demand. Such action by the District will not relieve the Contractor of the guarantees required by this article or elsewhere.

The faithful performance bond shall continue in full force and effect for the guarantee period.

If unsatisfactory or dangerous working conditions are observed, the District reserves the right to stop work immediately. All routine corrections and others identified by the District shall be addressed within one week after being notified.

This article does not in any way limit the guarantee on any items for which a longer guarantee is specified or on any items for which a manufacturer or supplier gives a guarantee for a longer period. The Contractor agrees to act as a co-guarantor with such manufacturer or supplier and shall furnish the District all appropriate guarantee or warranty certificates upon completion of the project. No guarantee period, whether provided for in this article or elsewhere, shall in any way limit the liability of Contractor or their sureties or insurers under the indemnity or insurance provisions herein.

2.1.3 LICENSES

All work shall be performed by a contractor licensed in the State of California with the designation of Class A. Work may be performed by a contractor with a C-34 License with prior District approval.

2.1.4 PERMITS

The Owner(s), Developer, or their Contractor shall secure all permits and licenses required by the agency or agencies having jurisdiction. Special attention is called to the District's connection fees and it shall be the Owner's responsibility to ascertain these charges and pay for them prior to any connections to the District water facilities, including lateral connections at property lines. Copies shall be submitted to the District prior to commencement of work. Connection permits will not be issued without payment of fees.

2.1.5 PLANS AND SPECIFICATIONS

1 GENERAL

The Contractor shall keep a copy of the approved plans, specifications, District standards, and all permits at the worksite which the District Inspector or Engineer shall always have access at all times.

2 SHOP DRAWINGS

Shop Drawings are drawings, diagrams, illustrations, schedules, performance charts, brochures, and other data which are prepared by the Contractor or any subcontractor, manufacturer, supplier, or distributor and which illustrate some portion of the work. When shop drawings are required by the plans or specifications or requested by the District, the Contractor shall review, mark with their approval, and submit them for review. Shop drawings shall be transmitted with the District's standard transmittal. Drawings shall be submitted electronically and with one hard copy to the District Engineer and shall be accompanied by the District's letter of transmittal listing the drawings submitted. Drawings shall show the name of the project, the name of the Contractor, and, if any, the names of suppliers, manufacturers, and subcontractors. Shop drawings shall be submitted with promptness and in orderly sequence so as to cause no delay in execution of the work.

Shop drawings shall be complete in all respects. If the shop drawings show any deviations from the requirements of the plans and specifications because of standard shop practices or other reasons, the deviations and the reasons therefore shall be set forth in the letter of transmittal.

By submitting shop drawings, the Contractor represents that material, equipment, and other work shown thereon conforms to the plans and specifications, except for any deviations set forth in the letter of transmittal.

Within 30 calendar days after receipt of said drawings, the District Engineer will return two of the copies of the drawings to the Contractor with any comments noted thereon. If noted by the District Engineer, the Contractor shall correct the drawings and resubmit them in the same manner as specified for the original submittal. The Contractor in the letter of transmittal accompanying resubmitted shop drawings shall direct specific attention to revisions other than the corrections requested by the District Engineer on previous submittals.

The review by the District Engineer is for the purpose of confirming general conformance with the design concept of the project and general compliance with the plans and specifications and shall not be construed as relieving the Contractor of the full responsibility for: providing materials, equipment, and work required by the contract; the proper fitting and construction of the work; the accuracy and completeness of the shop drawings; selecting fabrication processes and techniques of construction; and performing the work in a safe manner.

No portion of the work requiring a shop drawing submittal shall commence until the submittal has been reviewed by the District Engineer and returned to the Contractor with a notation indicating that submittal is approved.

2.1.6 WORK TO BE DONE

The work shall be performed in a thorough workmanlike manner in accordance with the plans, profiles, and specifications that have been approved-by the District. All work shall conform to the lines, elevations, and grades shown on these plans and profiles.

The District's approval of the plans prepared by the Developer's Engineer denotes agreement with the plans as prepared and is not an acceptance of responsibility as to their accuracy or completeness. The Developer's Engineer shall be responsible for any error, coordination with other facilities, and interpretation of the plans. The intent is to obtain a completed facility that shall be in conformance with the approved plans and in accordance with the District's requirements and these specifications. All revisions and changes in the plans must be approved by the District.

2.1.7 RIGHT-OF-WAY

Rights-of-way or easements for the improvement as shown on the plans will be provided by the Developer. Unless otherwise provided, the Contractor shall make their own arrangements, pay for, and assume all responsibility for acquiring, using, and disposing of additional work areas and facilities temporarily required by the Contractor. The Contractor shall indemnify and hold the District harmless from all claims for damages occasioned by such actions.

2.2 CONTROL OF MATERIALS

2.2.1 MATERIALS AND WORKSMANSHIP

1 GENERAL

All materials, parts, and equipment furnished by the Contractor in the work shall be new, high grade, and free from defects. Workmanship shall be in accordance with the generally accepted standards. Materials and workmanship shall be subject to the District's approval.

Materials and workmanship not conforming to the requirements of these specifications shall be considered defective and will be subject to rejection. Defective work or material,

whether in place or not, shall be removed immediately from the site by the Contractor at their expense when directed by the District Engineer.

Materials in contact with potable water must be NSF 61 approved, where applicable.

2 STORAGE FACILITIES

The Contractor shall provide and maintain storage facilities and employ such measures as will preserve the specified quality and fitness of materials to be used in the work. Stored materials shall be reasonably accessible for inspection. The Contractor shall also adequately protect new and existing work and all items of equipment for the duration of the contract.

3 INSPECTION REQUIREMENTS

Unless otherwise specified, inspection is required at the jobsite for such typical materials and fabricated items as pipe, valves, fittings, service materials, structural concrete, welding, and protective coating application.

4 TESTS OF MATERIALS

Before incorporation in the work, the Contractor shall submit samples of materials, as the District Engineer may require, at no cost to the District. The Contractor, at their own expense, shall deliver the materials for testing to the place and at the time designated by the District Engineer. Unless otherwise provided, all initial testing and required retesting shall be performed under the direction of the District Engineer at no expense to the Contractor. Unless otherwise stated, all other material testing shall be performed and paid for by the District.

2.3 UTILITIES

2.3.1 LOCATION

The Developer shall be responsible for searching utility records and indicating the location of utilities on the plans.

At least two working days before beginning the work, the Contractor shall request all utility owners to mark or otherwise indicate the location of their substructures. It shall be the Contractor's responsibility to determine the true location and depth of all utilities and service connections. The Contractor is also responsible for notifying DigAlert. The Developer shall also familiarize themselves with the type, material, age, and condition of any utility that may be affected by the work.

2.3.2 PROTECTION

The Contractor shall not interrupt the service function or disturb the supporting base of any utility without authority from the Utility Owner.

Where protection is required to ensure support of utilities, the Contractor shall furnish and place the necessary protection at their expense.

The Contractor shall immediately notify the District Engineer, designated District Representation, and the utility owner if they disturb, disconnect, or damage any utility.

2.4 RESPONSIBILITIES OF CONTRACTOR IN CONDUCT OF WORK

2.4.1 CONSTRUCTION SCHEDULE AND OF WORK

No work shall commence without a preconstruction meeting. The Contractor shall submit a schedule to the District Engineer outlining their proposed construction sequencing. Whenever the Contractor varies the period during which work is carried out each day, the Contractor shall give 48-hour notice to the Engineer so that proper inspection may be provided. When the Contractor's work becomes less than a full day's activity, it shall be the Contractor's responsibility to notify the Inspector daily of the work requiring inspection. Any work done in the absence of the Inspector shall be subject to rejection. Inspections shall not be scheduled on Fridays without prior permission by the District.

2.4.2 PUBLIC CONVENIENCE AND SAFETY

The Contractor shall conduct their operations as to offer the least possible obstruction and inconvenience to the public and shall have under construction no greater length or amount of work than can be performed properly with due regard to the rights of the public.

Convenient access to driveways, houses, and buildings along the line of work shall be maintained and temporary crossings shall be provided and maintained in good condition. Not more than one crossing or intersecting street or road shall be closed at any one time.

The Contractor shall provide and maintain such fences, barriers, directional signs, lights, and flagmen as necessary to give adequate warning to the public at all times of any dangerous conditions to be encountered because of the construction work and to give directions to the public. Any impacts to traffic signals shall be coordinated with the agency having jurisdiction and the Contractor shall bear the cost.

2.4.3 NO PERSONAL LIABILITY

Neither the members of the Board of Directors, nor any officer, employee, or authorized assistant or consultant of the District or District Engineer shall be personally responsible for any liability arising out of the work performed.

2.4.4 RESPONSIBILITY FOR DAMAGE

Neither the District, the Board of Directors, the District Engineer, nor their respective officers, employees, or agents shall be answerable or accountable in any manner for any loss or damage that may happen to the work or any part thereof; or for any material or equipment used in performing the work, or for injury or damage to any person or persons, either workmen or the public, or for damage to property through any cause whatsoever during the progress of the work or at any time before final acceptance.

2.4.5 LEGAL RELATIONS AND RESPONSIBILITY

The Contractor shall keep itself fully informed of all laws, ordinances, codes, standards, and regulations which in any manner affect those engaged or employed in the Work, or the materials used in the Work, or which in any way effect the conduct of the Work and of all such orders and decrees of bodies or tribunals having any jurisdiction or authority over the same. If any discrepancy or inconsistency is discovered in the plans, drawings, specifications, or other documents in relation to any such law, ordinance, regulation, order of decree, the Contractor shall forthwith report the same to the District in writing. The Contractor shall at the time observe and comply with and shall cause all of its agents and employees to observe and comply with all such existing, ordinances, resolutions, regulations, orders and decrees and shall, to the maximum extent permitted by law, protect and indemnify the District and its Board of Directors, officers, employees, and agents against any and all claims, liabilities, damages, losses, or costs (including attorney fees and costs) arising from or based on the violation of any such law, ordinance, regulation, order or decree, whether by the Contractor or its employees.

2.4.6 INSURANCE

A. General

Prior to commencement of subject Work, the Contractor, in addition to other requirements with respect to insurance, shall meet the District's insurance requirements or contract insurance requirements and shall provide the District with a Certificate of Insurance. A Certificate of Insurance shall be presented to the District before inspection is scheduled and performed. If the work is for, connects to, or is within the boundary of another public agency, city, county, or on private property, such agency, city, county, or property owner shall, along with the District be added to the Contractor's policy as an additional insured by way of an endorsement per the District's current requirements. Higher insurance requirements may be required depending on the scope of work and will be determined by the District when the permit is issued.

2.4.7 STORAGE OF EQUIPMENT AND MATERIALS IN PUBLIC STREETS

Construction materials may not be stored in streets, roads, or highways for a period longer than that authorized by the agency having jurisdiction over said street, road, or highway.

Construction equipment shall not be stored at the worksite before its actual use on the work or for a period longer than that authorized by the agency having jurisdiction over said street, road, or highway.

2.4.8 STREET CLOSURES, DETOURS AND BARRICADES

The Contractor shall comply with all applicable state, county, and city requirements for closure of streets. The Contractor shall provide barriers, guards, lights, signs, temporary bridges, flagmen, and watchmen advising the public of detours and construction hazards. The Contractor shall also be responsible for compliance with additional public safety requirements that may arise during construction. The Contractor shall furnish, install, and promptly remove all signs and warning devices upon completion of the work.

At least two working days before closing, partially closing, or reopening of any street, alley, or other public thoroughfare, the Contractor shall notify the police, fire, traffic, and engineering departments of jurisdictional agencies involved and comply with their requirements. Deviations must first be approved by the agency having jurisdiction and the District Engineer.

2.4.9 SAFETY

1 SAFETY ORDERS

The Contractor shall have at the worksite copies or suitable extracts of Construction Safety Orders, Tunnel Safety Orders, and General Industrial Safety Orders issued by the State Division of Industrial Safety. They shall comply with provisions of these and other applicable laws, ordinances, and regulations.

2 USE OF EXPLOSIVES

Explosives may be used only when authorized in writing by the District Engineer or as otherwise stated in the special provisions. Explosives shall be handled, used, and stored in accordance with all applicable regulations. The Contractor must have approved permits for work involving explosives.

The District Engineer's approval of the use of explosives shall not relieve the Applicant from their liability for claims caused by blasting operations.

3 SITE SAFETY

In accordance with generally accepted construction practices, the Contractor shall be solely and completely responsible for conditions of the jobsite, including safety of all persons and property during performance of the work, and the Contractor shall fully comply with all state, federal and other laws, rules, regulations, and orders relating to safety of workers and all others. The District reserves the right to halt work if unsafe or unsatisfactory conditions are observed.

4 EXCAVATIONS

The Contractor shall comply with all safety ordinances and orders and shall be solely responsible for the safety conditions of the Work.

The Contractors shall submit a detail showing the design of shoring, bracing, sloping, or other provisions to be made for worker protection from the hazards of caving ground during the excavation of any trench 5 feet or more in depth.

The plan submitted shall be stamped and signed by a Civil or Structural Engineer Registered in the State of California to certify that the plan complies with all OSHA guidelines, rules and regulations. The District reserves the right to stop work if unsafe conditions are observed.

The Inspector will not inspect trenches which do not conform to OSHA trench safety standards.

5 CONFINED SPACE OPERATION

District facilities should not be entered without first checking for unsafe atmosphere conditions, if found safe, entry shall only be made with the use of adequate air blowers and safety harnesses in accordance with confined space safety standards by a minimum of two people outside the facility. Proper air monitoring shall always be used to monitor for L.E.L., H₂S, carbon monoxide and oxygen deficiency before and during performance of work.

6 TRAFFIC CONTROL

Prior to undertaking the work, traffic control plans shall be submitted to the Agency having jurisdiction of the street for approval. A copy of the plans, the approved permit, and requirement therefore shall be provided to the Engineer.

In no case shall the traffic control be less than that required by the latest Work Area Traffic Control Handbook (WATCH) Manual.

Traffic control shall be in accordance with the latest WATCH Manual and City, County, or California Department of Transportation regulations and based on the speed limits posted in the work zones. Contractor shall apply for all traffic control permits and pay all fees for said permits.

Contractor shall provide all the necessary traffic control equipment and staff to adhere to the regulations set forth by the authority(s) having jurisdiction and in accordance with the traffic control plans that may have been reviewed and approved by said authority(s).

2.5 INSPECTION PROCEDURES

2.5.1 NOTICE OF STARTING CONSIDERATION

Notice shall be given to the District at least 48 hours (two working days) before starting construction.

2.5.2 HOURS OF INSPECTION

District Inspectors are available between the hours of 7:30 a.m. and 5:00 p.m., Monday through Thursday excluding District holidays. Inspection during other periods will be provided only if written permission is obtained from the District Engineer. In addition to inspection fees normally collected, Applicants will be required to pay the District the wages of the Inspector for all overtime work of the inspector. Such overtime shall be calculated as the hourly wage and benefit cost of the employee involved times a multiplier of 1.5.

2.5.3 INSPECTION OF WORK

All work shall be subject to inspection by the District and shall be left open and uncovered until approved by appropriate District authority.

The Contractor shall not proceed with any subsequent phase of work until the previous phase has been inspected and approved by the District. Inspection shall be made at the following phases of work including:

1 WATER SYSTEM INSPECTIONS

1. Trench excavation and inspection of subgrade.
2. Placement and compaction of pipe bedding.
3. Placing pipe, fittings, and structures including service lines, hydrants, air vacs, blowoffs, valves, PRVs, etc.
4. Pouring all concrete anchors and thrust blocks.
5. Placing and compacting the pipe zone backfill.
6. Backfilling balance of trench to grade. (Compaction test to be performed by the District).
7. Pressure testing all mains and services.
8. Disinfecting testing and flushing.
9. Repaving trench cuts.
10. Raising valve box covers to finish grade and paint to District standards.
11. Installation of meter boxes, and water meters.

2.5.4 DISTRICT AUTHORITY

The District shall always have access to the work during construction and shall be furnished with every reasonable facility for gaining full knowledge, workmanship, and character of materials used and employed in the work. No pipe, fittings, or other materials shall be installed or backfilled until inspected and approved by the District or its representative. The Contractor shall give sufficient due notice in advance of backfilling to the District Inspector so that proper inspection may be provided.

Inspection of the work shall not relieve the Contractor of any obligations to complete the work as prescribed by the standard specifications. Defective work shall be made good before any testing or final inspection will be permitted. Any unsuitable materials may be rejected notwithstanding such defective work and unsuitable materials having been previously overlooked by the District.

The District shall have the authority to make field changes to the approved construction plans-as it deems necessary. Such changes may be ordered to avoid utility interferences, at areas of poor soil, or other previously unknown conditions. The Contractor shall be responsible for complying with the changes as ordered by the District and the Contractor shall notify the District of any additional costs. The Contractor shall also be responsible for indicating any such required changes upon a set of record drawings and furnishing such information to the District in accordance with Part II, Section A-4 1 of these Standard Specifications. Any increases in construction costs which result from changes ordered by the District, shall be entirely the responsibility of the District.

2.5.5 PLACING PORTIONS OF WATER MAINS IN SERVICE EARLY

The District may approve putting portions of newly installed water mains into service after compaction has been approved by the governing agency and the portions have been pressure tested, chlorinated, flushed, and have passed the bacteriological test for potable water mains. This partial acceptance shall be granted only upon written request from the Contractor and subsequent approval by the District Engineer. Upon this written approval for partial acceptance of facilities, the Contractor shall be relieved of the duty to maintain the portions so used or placed into operation; provided, however, that nothing in this section shall be construed as relieving the Contractor of full responsibility for completing the work in its entirety, for making good any defective work and materials, for protecting the work from damage, and for being responsible for damage and for work as set forth in the Agreement for Installation of Water Facilities; nor shall such action by the District be deemed completion and acceptance, and such action shall not relieve the Contractor of the provisions of Part II, Subsection A-2, "Guarantee."

2.5.6 FINAL WATER FACILITIES INSPECTION

Before final acceptance, the District Inspector will make a final inspection of all work accompanied by the Contractor's superintendent or foreman to check particularly on the following items:

1. Review that all phases of the job are completed in accordance with plans and specifications.
2. That all valve boxes are raised to finish grade, painted, and that all street restoration is completed.
3. That all valves are referenced out and the District Inspector has been given all reference measurements.
4. That all right-angle meter stops and meters are properly positioned and all meter boxes are positioned and raised to proper grade.
5. That fire hydrants and bollards are raised to proper grade, in a vertical position, painted, and the concrete pad poured with pavement markers.
6. That backfill has passed all compaction requirements.
7. That all system valves are turned and left open (except those specifically required to be normally closed); turns required for complete open/close cycle are recorded on the record drawings.
8. That all domestic water lines have been chlorinated and have passed testing.
9. That all line pressure testing and flushing have been completed.
10. That the jobsite is clean and all of the Contractor's equipment and materials are removed.
11. That all service lateral locations have been marked on curb.

2.5.7 INTERPRETATION OF SPECIFICATIONS AND DETAIL DRAWINGS

Figured dimensions of the drawings shall govern but work not dimensioned shall be as directed. Work not particularly shown or specified shall be the same as similar parts that are shown or specified or as directed. Full-size details shall take precedence over scale drawings as to shape and details of construction. Specifications shall govern as to material. Scale drawings, full-size details, and specifications are intended to be fully cooperative and to agree. Should any discrepancy or apparent difference occur between plans and

specifications, or should errors occur in projects being constructed by others affecting the work and the contractor proceeds with the work affected without instruction from the District, they shall be fully responsible for any resultant damage or defect.

2.5.8 RELEASE GIVEN TO COUNTY

All final inspection requirements shall be fulfilled before the District will give its final Notice of Completion to the county for release of the Developer's bonds.

DRAFT

3. DOMESTIC WATER SYSTEMS SPECIFICATIONS

Table of Contents

Section No.	Description
00810	Supplement to General Conditions
01092	General Abbreviations
01500	Construction Facilities and Temporary Conditions
01570	Traffic Regulation
01700	Cleaning During Construction & Final Cleaning
01730	Operation and Maintenance Manuals
02222	Protecting Existing Underground Utilities
02223	Trenching, Backfilling and Compacting
02315	Jacked Steel Casing
02513	Asphalt Concrete Pavement
02667	Hot-Tap Connections
03000	General Concrete Construction
09811	Fusion-Bonded Epoxy Linings and Coatings
09900	Painting and Coating
15000	Piping Schedule and General Piping Requirements
15041	Disinfection of Piping
15044	Pressure Testing of Piping
15056	Ductile-Iron Pipe
15057	Copper Tubing
15064	PVC Distribution Pipe (AWWA C900)
15100	Manual, Check, and Process Valves
15108	Air-Release and Vacuum-Relief Valves
15109	Fire Hydrants
15112	Backflow Prevention
15122	Flexible Pipe Couplings
15123	Corporation Stops and Service Saddles
16640	Cathodic Protection and Joint Bonding

SECTION 00810 SUPPLEMENTAL TO THE GENERAL CONDITIONS

1.01 DEFINITIONS

- A. Whenever the following terms occur in these specifications their meaning is as follows:

OWNER	The applicant requesting the installation or construction of water systems for integration with the water system of the District.
CONTRACTOR	The persons, firm, or corporation entering into contract with the Owner or Developer for the performance of Work required under said contract, the District ordinances and these requirements.
SECTIONS 00800 TO 01999	Special Conditions Modifications to general requirements of the specifications.
SECTIONS 02000 TO 016999	Construction Details Numbered section subjects are selected for indexing convenience only and do not indicate division of work among trades or subcontractors.

1.02 TERMS

- A. Command type sentences used in the contract documents refer to and are directed to the Contractor.

1.03 ACCESS TO CONFINED SPACES IN EXISTING STRUCTURES

- A. Potentially, existing structures within the District where work might be performed may be defined as "confined spaces" or "permit-required confined spaces" per OSHA rules and regulations.

END OF SECTION

SECTION 01092 GENERAL ABBREVIATIONS

1.01 GENERAL

- A. Interpret abbreviations used on the drawings and in the specifications as tabulated below. If an abbreviation on a drawing is not explained below, it shall be as explained in ANSI Y1.1. The interpretation of abbreviations shall consider the context or discipline in which they are used, for example:

1. FF usually means “finish floor” when referring to a floor slab.
2. FF usually means “flat face” when referring to a pipe flange.

1.02 LIST OF GENERAL ABBREVIATIONS

<u>Abbreviation</u>	<u>Term</u>
A	Ampere/Area
AA	Aluminum Association
AABC	Associated Air Balance Council
AAMA	Architectural Aluminum Manufacturer’s Association
AAS	Airport Advisory Service
AASHTO	American Association of State Highway and Transportation Officials
AB	Anchor Bolt/ Aggregate Base
ABAN	Abandoned
ABC	Asphalt Base Course
ABT	About
AC	Acre/ Asphalt Concrete/ Alternating Current/ Air Conditioning
ACCU	Air Cooled Condensing Unit
ACGIH	American Conference of Governmental Industrial Hygiene
ACI	American Concrete Institute
ACP	Asbestos-Cement Pipe
ACU	Air Conditioning Unit
AD	Access Door
ADDL	Additional
AE	Architect-Engineer
AF	Air Filter/ Ampere Frame
AFB	Air Force Base
AFBMA	Anti-Friction Bearing Manufacturer’s Association
AGA	American Gas Association
AGMA	American Gear Manufacturer’s Association

<u>Abbreviation</u>	<u>Term</u>
AHD	Ahead
AHU	Air Handling Unit
AI	The Asphalt Institute
AIA	American Institute of Architects
AICS	Amperes Interrupting Capacity, Symmetrical
AIEE	American Institute of Electrical Engineers
AISC	American Institute of Steel Construction
AISI	American Iron and Steel Institute
AL	Aluminum
ALIGN	Alignment
ALM	Alarm
ALTN	Alternate
AMB	Ambient
AMCA	Air Movement and Control Association
AMP	Ampere
ANCH	Anchor
ANG	Angle
ANSI	American National Standards Institute
API	American Petroleum Institute
APPROX	Approximate
APWA	American Public Works Association
ARCH	Architecture/ Architectural
AREA	American Railway Engineering Association
ARI	Air Conditioning and Refrigeration Institute
ARV	Air-Release Valve
ARVV	Air-Release/ Vacuum Valve
ASCE	American Society of Civil Engineers
ASHRAE	American Society of Heating, Refrigerating, and Air Conditioning Engineers
ASME	American Society of Mechanical Engineers
ASPH	Asphalt
ASSY	Assembly
ASTM	American Society of Testing and Materials
ATS	Automatic Transfer Switch
AVE	Avenue

AbbreviationTerm

AVG	Average
AWG	American Wire Gauge
AWPA	American Wood Preservers Association
AWPB	American Wood Preservers Bureau
AWS	American Welding Society
AWWA	American Water Works Association
BB	Back-to-Back
BC	Beginning of Curve/Back of Curve/ Bolt Circle
BCR	Begin Curb Return
BEG	Begin
BETW	Between
BF	Blind Flange
BHP	Brake Horsepower
BK	Back/Brake
BKR	Breaker
BL	Base Line
BLDG	Building
BLK	Block
BM	Bench Mark/ Beam
BO	Blowoff
BOCA	Building Officials Code Administration International, Inc.
BOD	Biochemical Oxygen Demand
BOT	Bottom
BP	Baseplate
BR	Bronze/ Branch
BRG	Bearing
BTN	Button
BTU	British Thermal Unit
BUR CBL	Buried Cable
BV	Butterfly Valve
BVC	Begin Vertical Curve
BW	Block Wall
C	Conduit/ Celsius
CAB	Crushed Aggregate Base
CALTRANS	California Department of Transportation
CANTIL	Cantilevered
CAP	Capacity
CATV	Cable Television
CB	Catch Basin/ Circuit Breaker
CC	Cooling Coil

<u>Abbreviation</u>	<u>Term</u>
C-C	Center-to-Center
CCB	Concrete Block
CCP	Concrete Cylinder Pipe
CCS	Central Control Station
CD	Cross Drain/ Condensate Drain/ Ceiling Diffuser
CEM	Cement
CF	Cubic Feet/ Curb Face
CFH	Cubic Feet Per Hour
CFM	Cubic Feet Per Minute
CFS	Cubic Feet Per Second
CG	Ceiling Grill
C & G	Curb and Gutter
CH	Chiller
CHG	Change
CHKD PL	Checkered Plate
CI	Cast Iron
CIP	Cast in Place/ Cast-Iron Pipe
CISP	Cast Iron Soil Pipe
CISPI	Cast-Iron Soil Pipe Institute
CJ	Construction Joint
CL	Centerline/Class/Clearance
CLR	Clear
CMAA	Crane Manufacturer's Association of America
CMC	Cement-Mortar Coated or Coating
CML	Cement-Mortar Lined or Lining
CMLCSP	Cement-Mortar Lined and Coated Steel Pipe
CMP	Corrugated Metal Pipe
CMPA	Corrugated Metal Pipe Arch
CMU	Concrete Masonry Unit
CO	Cleanout/ Conduit Only
COL	Column
COMM	Communication
COMP	Composite
COMPL	Complete
CONC	Concrete
CONN	Connection
CONST	Construct or Construction
CONT	Continuous
CONTR	Contractor
COORD	Coordinate/ Coordinated
COP	Copper

Abbreviation

Term

COR	Corner
CPLG	Coupling
CPU	Central Processing Unit
CRES	Corrosion Resistant Steel
CRSI	Concrete Reinforcing Steel Institute
CS	Carbon Steel/ Commercial Standard
CSP	Corrugated Steel Pipe
CT	Center Top/ Current Transformer
CTG	Coating
CTR	Center
CTV	Cable Television
CULV	Culvert
CU YD, CY	Cubic Yard
CYL	Cylinder
D	Degree of Curvature
DB	Direct Buried/ Decibel
DBL	Double
DC	Direct Current
DEPT	Department
DET	Detail/ Detour
DG	Decomposed Granite
DI	Drop Inlet/ Ductile Iron
DIA	Diameter
DIAG	Diagonal
DIM	Dimension
DIMJ	Ductile-Iron Mechanical Joint
DIP	Ductile-Iron Pipe
DIPRA	Ductile-Iron Pipe Research Association
DISCH	Discharge
DIST	Distance
DIV	Divide/ Division
DO	Dissolved Oxygen
DMH	Drop Manhole
DN	Down
DP	Differential Pressure
DPI	Differential Pressure Indicator
DPNL	Distribution Panel
DR	Drain/ Door
DSL	Diesel
DWG	Drawing
DWY	Driveway
E	East

Abbreviation

Term

EA	Each
EC	End of Curve
ECC	Eccentric
ECR	End of Curb Return
ED	External Distance
EE	Each End
EF	Each Face/ Exhaust Fan
EFF	Efficiency
EFL	Effluent
EG	Exhaust Grill
EGL	Energy Grade Line
EL	Elevation/ Each Layer
ELEC	Electric
ELEV	Elevation
ELP	Elliptical
EMB	Embankment
ENC	Encasement
ENCL	Enclosure
ENG	Engine
ENGR	Engineer
EOCWD	East Orange County Water District
EOP	Edge of Pavement
EOS	Equivalent Opening Size
EOTW	Edge of Traveled Way
EP	Explosion Proof/ Edge of Pavement
EPA	Environmental Protection Agency (Federal)
EQ	Equation
EQL	Equal
ESMT	Easement
EST	Estimate of Estimated
ETC	And so Forth
ETM	Elapsed Time Meter
EVAP	Evaporator
EVC	End Vertical Curve
EW	Each Way
EWC	Electric Water Cooler
EXC	Excavate or Excavation
EXP	Expansion
EXST	Existing
EXT	Exterior/ Extension
F	Fahrenheit/ Floor
FAA	Federal Aviation Administration

Abbreviation

FAB
FBRBD
FC
FCC
FCO
FCV
FD
FDN
FDOT
FE
FF
FG
FHY
F & I
FIG
FIN
FIT
FL
FLEX
FLG
FLT
FLUOR
FM
FMH
FNSH
FOC
FOS
FPC
FPM
FPS
FPT
FS

FSTNR
FT
FTG
FUT
FWY
G
GA
GAL
GALV
GAS
GB

Term

Fabricate
Fiberboard
Foot-Candle
Filter Control Console
Floor Cleanout
Flow Control Valve
Floor Drain
Foundation
Florida Department of Transportation
Flanged End
Finished Floor/ Flat Face
Finished Grade
Fire Hydrant
Furnish and Install
Figure
Final
Fitting
Floor/ Flow Line
Flexible/ Flexure
Flange
Float
Fluorescent
Force Main/ Factory Mutual
Flexible Metal Hose
Finish
Face of Concrete
Face of Stud
Flexible Pipe Coupling
Feet Per Minute
Feet Per Second
Female Pipe Thread
Finished Surface/ Floor Sink/ Federal Specifications
Fastener
Feet or Foot
Footing
Future
Freeway
Gas
Gauge
Gallon
Galvanized
Gasoline
Grade Break

Abbreviation

Term

GDR	Guard Rail
GE	Grooved End
GEN	Generator
GENL	General
GFI	Ground Fault Interrupter
GM	Gas Main
GMT	Greenwich Main Time
GND	Ground
GPD	Gallons Per Day
GPM	Gallons Per Minute
GR	Grade
GRTG	Grating
GSKT	Gasket
GUT	Gutter
GV	Gate Valve
GWB	Gypsum Wallboard
GWBX	Gypsum Wallboard, Fire Rated
GYP	Gypsum
H	Humidistat/ Horizontal
HARN	Harness
HB	Hose Bibb
HC	Heating Coil
HD	Heavy Duty
HDPE	High Density Polyethylene
HEPA	High Efficiency Particulate Air
HGL	Hydraulic Grade Line
HGT	Height
HID	High Intensity Discharge
HOA	Hand-Off-Automatic
HOR	Hand-Off-Remote
HORIZ	Horizontal
HP	Horsepower/ High Pressure
HPS	High Pressure Sodium
HPT	High Point
HR	Hour/ Handrail
HS	High Strength
HTG	Heating
HTR	Heater
HV	Hose Valve
HVAC	Heating, Ventilating, and Air Conditioning
HVY	Heavy
HW	Headwall/ Hot Water

<u>Abbreviation</u>	<u>Term</u>
HWL	High Water Level
HWY	Highway
HYDR	Hydraulic
HZ	Hertz (cycles per second)
I	Intersection Angle
ICBO	International Conference of Building Officials
ID	Inside Diameter
IE	Invert Elevation
IEEE	Institute of Electrical and Electronics Engineers
IN	Inches
INCAND	Incandescent
INCL	Include
INL	Inlet
INS	Insulating
INSTL	Install or Installation
INTR	Interior/ Intersection
INV	Invert
IP	Iron Pipe
IPS	Iron Pipe Size
IPT	Iron Pipe Thread
IRR	Irrigation
ISA	Instrument Society of America
J	Joist
JB	Junction Box
JCT	Junction
JN	Join
JT	Joint
KG	Kilogram
KM	Kilometer
KIPS	Thousands of Pounds
KV	Kilovolt
KVA	Kilovolt-Ampere
KW	Kilowatt
KWH	Kilowatt-Hour
KWHM	Kilowatt-Hour Meter
L	Length of Curve/ Long/ Left
LATL	Lateral
LAV	Lavatory

<u>Abbreviation</u>	<u>Term</u>
LB	Pound
LBR	Lumber
LCL	Local
LF	Linear Foot
LG	Long
LI	Level Indicator
LLO	Long Leg Outstanding
LOC	Location/ Locate
LOS	Lockout Stop
LP	Light Pole
LPT	Low Point
LR	Long Radius
LS	Lift Station
LT	Left/ Light
LTG	Lighting
LWC	Lightweight Concrete
LWIC	Lightweight Insulating Concrete
LWL	Low Water Level
MA	Milliampere
MAG	Magnet/ Magnetic
MATL	Material
MAX	Maximum
MB	Machine Bolt/ Megabyte/ Millibars
MBH	Thousand BTU Per Hour
MECH	Mechanical
MC	Metal Channel
MCC	Motor Control Center
MCM	Thousand Circular Mils
MCP	Motor Circuit Protector
MD	Motorized damper
MFR	Manufacturer
MG	Million Gallons/ Milligram
MGD	Million Gallons Per Day
MH	Manhole
MHZ	Megahertz
MI	Malleable Iron/Mile
MIL	Military Specifications
MIN	Minimum
MISC	Miscellaneous
MLSS	Mixed Liquor Suspended Solids
MLVSS	Mixed Liquor Volatile Suspended Solids
MJ	Mechanical Joint

Abbreviations

Term

MMA	Monorail Manufacturer's Association
MO	Motor Operator/ Motor Operated/ Masonry Opening
MOD	Modification
MON	Monument
MOT	Motor
MPT	Male Pipe Thread
MSL	Mean Sea Level
MSS	Manufacturer's Standardization Society
MSDS	Material Safety Data Sheet
MTD	Mounted
MUTCD	Manual on Uniform Traffic Control Devices
N	North/ Neutral/ Nitrogen
NA	Not Applicable
NBFU	National Board of Fire Underwriters
NBS	National Bureau of Standards
N & C	Nail and Cap
NC	Normally Closed
NE	Northeast
NEC	National Electric Code
NEMA	National Electrical Manufacturers Association
NFC	National Fire Code
NIC	Not in Contract
NIP	Nipple
NO	Number/ Normally Open
NOM	Nominal
NPT	National Pipe Taper
NRS	Non-rising Stem
NSF	National Sanitation Foundation
NTS	Not to Scale
NW	Northwest
NWL	Normal Water Level
OA	Overall/ Outside Air
OC	On Center/ Overcurrent
OD	Outside Diameter
ODP	Open Drip-proof
OE	Or Equal
OF	Outside Face
OPER	Operator
OPNG	Opening
OPP	Opposite
ORIG	Original

<u>Abbreviation</u>	<u>Term</u>
OSA	Outside Air
OSHA	Occupational Safety and Health Administration
O TO O	Out to Out
OVFL	Overflow
OVHD	Overhead
P	Pole
PARA	Paragraph
PB	Push Button/ Pull Box
PC	Point of Curvature/ Programmable Controller
PCA	Portland Cement Association
PCC	Point of Compound Curvature/ Portland Cement Concrete
PDI	Plumbing and Drainage Institute
PE	Plan End/ Polyethylene/ Professional Engineer
PEN	Penetration
PERF	Perforated
PF	Power Factor
PG	Pressure Gauge
PI	Point of Intersection
PJTN	Projection
PKWY	Parkway
PL	Plate/ Property Line
PLATF	Platform
PLF	Pounds Per Lineal Foot
PNL	Panel
POB	Point of Beginning
POC	Point of Construction
POJ	Push-on Joint
PP	Power Pole/ Polypropylene
PPB	Parts Per Billion
PPM	Parts Per Million
PR	Pair
PRC	Point of Reverse Curve
PRESS	Pressure
PRL	Parallel
PROV	Provisions
PRPSD	Proposed
PRVC	Point of Reverse Vertical Curve
PSI	Pounds Per Square Inch
PSIG	Pounds Per Square Inch Gauge
PSF	Pounds Per Square Foot

Abbreviation

PT
PV
PVC
PVMT
PWR
P&ID
Q
QTY
R
RAD
RAF
RAG
RC
RCB
RCP
RCPA
RD
RDC
RDCR
RDWY
REF
REINF
RELOC
REQ
REQD
RES
REV
RF
RH
RND
RJ
RLG
RPM
RR
RST
RT
RTD
RW
R/W
S
SAE

Term

Point of Tangency
Plug Valve
Polyvinyl Chloride
Pavement
Power
Process and Instrumentation Diagram
Flow rate
Quantity
Right/ Radius
Radius/ Radial
Return Air Fan
Return Air Grille
Reinforced Concrete
Reinforced Concrete Box
Reinforced Concrete Pipe
Reinforced Concrete Pipe Arch
Road
Reduce
Reducer
Roadway
Reinforce/ Reference
Reinforce or Reinforced
Relocated
Required/ Requirement
Required
Reservoir
Revise/ Revision
Raised Face
Relative Humidity
Round
Restrained Joint
Railing
Revolutions Per Minute
Railroad
Reinforcing Steel
Right
Resistance Temperature Detector
Recycled Water / Reclaimed Water
Right-of-Way
South/ Slope in Feet Per Foot/ Sewer
Society of Automotive Engineers

Abbreviation

Term

SAN	Sanitary
SAR	Supply Air Register
SBCCI	Southern Building Code Congress International
SC	Seal Coat
SCADA	Supervisory Control and Data Acquisition
SCFM	Standard Cubic Feet Per Minute
SCHED	Schedule
SCR	Silicon-Controlled Rectifier
SCRN	Screen
SD	Storm Drain
SDG	Siding
SDI	Steel Deck Institute
SDWK	Sidewalk
SE	Southeast
SECT	Section
SF	Square Feet
SGL	Single
SH	Sheet/ Sheeting/ Shielded
SIM	Similar
SLP	Slope
SLV	Sleeve
SM	Sheet Metal
SOL	Solenoid
SOV	Solenoid-Operated Valve
SP	Space/ Steel Pipe/ Static Pressure/ Spare
SPCG	Spacing
SPEC	Specification
SPLC	Splice
SPRT	Support
SQ	Square
SQ FT	Square Feet
SR	Short Radius
SS	Sanitary Sewer
SSPC	Steel Structures Painting Council
SST	Stainless Steel
ST	Street
STA	Station
STBY	Standby
STD	Standard
STK	Stake
STL	Steel

Abbreviation

STR
STRL
STRUCT
STS
STGR
STWY
SURF
SW
SWG
SYMM
SYS
T
TAN
T/B
TB
T & B
TBG
TBM
TC
TD
TDH
TDS
TEFC
TEL
TEMP
TENV
THB
THD
THH
THK
TIR
TO
T/O
TOC
TOS
TOT
TP
TRD
TRA
TS
TV
TYP

Term

Straight
Structural
Structure
Storm Sewer
Stringer
Stairway
Surface
Southwest
Swing
Symmetrical
System
Ton/ Tangent Length of Curve/ Telephone
Tangent
Top of Beam
Top of Bank/ Terminal Board
Top and Bottom
Tubing
Temporary Bench Mark
Top of Curb / Traffic Control
Time Delay
Total Dynamic Head
Total Dissolved Solids
Totally Enclosed Fan Cooled
Telephone
Temperature/ Temporary
Totally Enclosed Nonventilated
Thrust Block
Thread or Threaded
Thrust Harness
Thick
Total Indicator Reading
Turnout
Top of
Top of Concrete
Top of Slab
Total
Telephone Pole
Tread
Tie Rod Assembly
Tube Steel
Television
Typical

Abbreviation

Term

UBC	Uniform Building Code
UD	Underdrain
UG	Underground
UH	Unit Heater
UL	Underwriters' Laboratories, Inc.
ULT	Ultimate
UNO	Unless Noted Otherwise
UPS	Uninterruptible Power Supply
UR	Urinal
USGS	United States Geological Survey
UTC	Underground Telephone Cable
UTIL	Utilities
UTR	Up Through Roof
V	Vent/ Volt/ Valve
VAC	Vacuum/ Volts, Alternating Current
VC	Vertical Curve
VCP	Vitrified Clay Pipe
VEL	Velocity
VERT	Vertical
VFD	Variable Frequency Drive
VOL	Volume
VPC	Vertical Point of Curvature
VPI	Vertical Point of Intersection
VPT	Vertical Point of Tangency
VSS	Volatile Suspended Solids
VTR	Vent Through Roof
W	West/ Watt/ Wide/ Water
W/	With
WC	Water Closet
WCO	Wall Cleanout
WG	Water Gauge
WH	Wall Hydrant
WL	Waterline
WLD	Welded
WM	Water Meter/ Working Point
WRGWB	Water-Resistant Gypsum Wallboard
WSE	Water Surface Elevation
WSP	Water Stop
WT	Weight
WTR	Water
WWF	Welded Wire Fabric
WWM	Woven Wire Mesh

Abbreviation

XFMR

XFR

YCO

YD

YP

YR

YS

Term

Transformer

Transfer

Yard Cleanout

Yard

Yield Point

Year

Yield Strength

END OF SECTION

DRAFT

SECTION 01500 CONSTRUCTION FACILITIES AND TEMPORARY CONTROL

1.01 CONSTRUCTION WATER

A. Related Work Specified Elsewhere

1. Trenching, Backfilling, and Compacting: 02223
2. General Concrete Construction: 03000

B. The Contractor shall make their own arrangements for developing water sources and supply all labor and equipment to collect, load, transport, and apply water as necessary for compaction of materials, concrete construction operations, testing, dust control, and other construction use. Water shall be clean and free from objectionable deleterious amounts of acids, alkaline, salts, or organic materials.

C. The Contractor shall purchase water from the District or obtain water from private sources. Hydrant meter may be obtained from the District or local water provider. Contractor shall be charged current retail rate for water used for construction. A deposit shall be required to obtain the hydrant meter.

1.02 ELECTRICAL POWER – CONSTRUCTION PHASE

A. The Contractor shall provide for the purchase of power or provide portable power for the construction of the project where existing outlets are not available. Provide for the extension of utility lines to the point of usage.

1.03 DUST CONTROL

A. The Contractor shall perform dust control operations to prevent construction operations from producing dust in amounts harmful to persons or causing a nuisance to persons living nearby or occupying buildings in the vicinity of the work. Use water or dust preventative to control dust. Their supply and application shall be at the expense of the contractor.

1.04 FIRE DANGER

A. The Contractor shall minimize fire danger in the vicinity of and adjacent to the construction site. Provide labor and equipment to protect the surrounding private property from fire damage resulting from construction operations. All costs arising from fire or the prevention of fire shall be at the expense of the Contractor.

B. The Contractor shall provide personnel to perform fire watch during operations involving potential for fire.

1.05 SANITARY FACILITIES

- A. The Contractor shall provide sanitary facilities complying with the California Code of Regulations Title 8 Section 1526. Facilities must be maintained in accordance with OSHA standards.

END OF SECTION

DRAFT

SECTION 01570 TRAFFIC REGULATION

1.01 DESCRIPTION

- A. This section describes procedures for traffic regulation during construction in streets and highways.

1.02 STANDARD SPECIFICATIONS

- A. Whenever reference is made to the State Specifications and Plans, such reference shall mean the State of California, California State Transportation Agency, Department of Transportation, Standard Specifications and Plans, the latest edition.

1.03 SUBMITTALS

- A. When work is performed in public right-of-way, submit traffic control plan to authorities with jurisdiction over the work area.
- B. When work is performed on private roads, submit traffic control plan to District, if requested.
 - 1. The Contractor shall submit, not less than ten (10) working days prior to start of construction operations, a plan, prepared, signed, and sealed by a California licensed civil or traffic engineer. Preparation of any additional traffic control plans or detail that may be required during the work shall be the Contractor's responsibility. No work shall begin requiring traffic control until a traffic control plan is approved.
- C. The Contractor shall submit traffic control plan in accordance with the General Conditions.

1.04 GENERAL

- A. Provide safe and continuous passage for pedestrian and vehicular traffic at all times.
- B. Control traffic at those locations indicated and in conformance with the approved traffic control plans and specifications.
- C. Furnish, construct, maintain, and remove detours, road closures, traffic signal equipment, lights, signs, barricades, fences, K-rail, flares, solar-powered flashing arrow signs, miscellaneous traffic devices, flagmen, drainage facilities, paving and other items and services necessary to safeguard the public from hazard and inconvenience. All such work shall comply with the ordinances, directives, and regulations of authorities with jurisdiction over the public roads in which the construction takes place and over which detoured traffic is routed by the Contractor. After devices have been installed, the Contractor shall maintain and keep them in good repair and working order until no longer required.

- D. Prior to the start of construction operations, the Contractor shall notify the police, and fire department in whose jurisdiction the project lies, giving the expected starting date, completion date, and the names and telephone numbers of responsible persons who may be contacted at any hour in the event of a condition requiring immediate emergency service to remove, install, relocate, and maintain warning devices. In the event these persons do not promptly respond, or the authority deems it necessary to call out other forces to accomplish emergency service, the Contractor will be held responsible for the cost of such emergency service.
- E. Post temporary "No Parking - Tow Away" signs 48 hours prior to work in areas where parking is normally permitted. The police department shall be notified prior to the posting of any temporary parking restrictions along the pipeline route.
- F. Coordinate the relocation of public bus and school bus routes, bus stops, and trash collection services with the agencies listed on the plans in advance of construction activity.
- G. Notify each postal address prior to restricting parking along the project route via traffic boards up to two weeks in advance. Door tags in the project area will be distributed one to two weeks in advance.

1.05 TRAFFIC CONTROL DEVICES AND SIGNS

- A. Traffic control shall be in accordance with the latest Work Area Traffic Control Handbook (WATCH) Manual and City, County, or California Department of Transportation regulations and based on the speed limits posted in the work zones.
- B. Traffic control devices and temporary striping shall conform to the State Standard Plans and Specifications. Construction signs shall conform to the latest edition of the State of California Sign Specification Sheets.
- C. The placement of construction signing, striping, barricades, and other traffic control devices used for handling traffic and public convenience shall conform to the latest edition of the State of California, Department of Transportation, "Manual of Traffic Controls Devices (MUTCD)".
- D. Signs shall be illuminated or reflectorized when they are used during hours of darkness. Cones and portable delineators used for night lane closures shall have reflective sleeves. Barricades used in the diversion of traffic shall be equipped with flashers if in place during hours of darkness.
- E. During the duration of a detour, cover all existing signs not in accordance with the traffic control plan. Existing signs which are in force shall be relocated to provide visibility from all relocated traffic lanes.

1.06 VEHICULAR TRAFFIC CONTROL

- A. General: Accomplish construction in phases by detouring traffic from its normal patterns along the route between cross streets to form the construction zone. Restore traffic to normal patterns in each phase before proceeding to the next phase. Shoring members, beams, or other obstructions shall not be permitted within a 2-foot clearance between the edge of excavation and the edge of any traffic lane. At construction areas where an open trench exists and/or where traffic detour will be in existence during night hours, replace delineators with appropriate delineation per agency having jurisdiction.

1.07 PEDESTRIAN TRAFFIC CONTROL

- A. Always maintain and delineate a minimum of one 4-foot-wide pedestrian walkway along each public street during construction. Always maintain existing pedestrian accesses at intersections. When existing crosswalks are blocked by construction activity, install signing directing pedestrian traffic to the nearest alternative crosswalk.
- B. Erect a fence or provide other means of securement to preclude unauthorized entry to any excavation during all nonworking hours on a 24-hours basis including weekends and holidays. Said fence shall be a minimum of 7 feet high around the entire excavation, consisting of a minimum 9-gauge chain link type fence fabric and shall be sturdy enough to prohibit toppling by children or adults. There shall be no openings under the wire large. All gates shall be locked. Place warning signs spaced on 50-foot centers on the outside of the fence with the statement "DEEP HOLE DANGER".
- C. Special Considerations at Schools: When construction is within 500 feet of any school crossing, the Contractor shall notify school personnel at least seven working days before start of construction.

1.08 ACCESS TO ADJACENT PROPERTIES

- A. General: Maintain reasonable access from public streets to all adjacent properties during construction. Prior to restricting normal access from public streets to adjacent properties, notify each property owner or responsible person by mail 7 days prior and hang door tags at least 72 hours in advance. The notice shall include the nature of the access restriction, the approximate duration of the restriction, and the best alternate access route for that particular property.
- B. Special Considerations at Fire Stations: Do not hinder unobstructed ingress and egress at any time to fire stations.
- C. If the pipeline route passes shopping centers with driveway access from the street: minimize access restriction to these driveways. Either backfill, compact, and provide temporary pavement or provide non-skid steel plates in accordance with the State Specifications sufficient to support vehicular traffic across the trench in front of these driveways except when actual construction is being performed in the driveway area.

1.09 PERMANENT TRAFFIC CONTROL DEVICES

- A. General: Existing permanent traffic control signs, barricades, and devices shall remain in effective operation unless a substitute operation is arranged for and approved as a portion of vehicular traffic control above. All traffic signal modification and restoration work shall be in accordance with the agency having jurisdiction.
- B. Contractor shall completely restore all traffic signals affected by the construction of the pipeline to its original operation immediately upon completion of the work requiring the signal modification.
- C. Traffic Control Detection Loops: Contractor shall completely replace traffic control detection loops which are cut, removed, or otherwise disturbed to the original position immediately after the specific stage affecting loops is completed. New loops shall be checked by the Contractor for continuity from the traffic signal cabinet to assure splicing and signal operation is correct.
- D. Replace traffic signal conduits damaged to the nearest pull box, including new wire, back to the terminal, and/or back to the signal controller to the satisfaction of the owning agency before proceeding to the next construction stage. Splicing is not permitted. All such damage shall be reported immediately to the owning agency.
- E. Restriping of Streets: Permanent restriping shall be in accordance with the requirements of the agencies having jurisdiction. Place and remove temporary striping required for traffic control during construction by sandblasting or other method required by the agency having jurisdiction. Temporary striping includes any striping required on any pavement replaced prior to the final surface course. Replace any damaged or obliterated raised pavement markers in accordance with the standards of the agency having jurisdiction.

END OF SECTION

SECTION 01700 CLEANING DURING CONSTRUCTION & FINAL CLEANING

1.01 GENERAL

- A. This section includes cleaning during construction and final cleaning on completion of the work.
- B. At all times maintain areas covered by the contract, adjacent properties, and public access roads free from accumulations of waste, debris, and rubbish caused by construction operations.
- C. Cleaning and disposal operations shall comply with local and state laws.
- D. Use only cleaning materials recommended by manufacturer of surface to be cleaned.

1.02 CLEANING DURING CONTRUCTION

- A. During execution of work, the job site must be kept clean. All areas impacted by constructing, including adjacent properties, streets and access roads must also be kept clean.
- B. Wet down dry materials and rubbish to prevent dust.
- C. Provide containers for collection and disposal of waste materials, debris, and rubbish.
- D. Cover or wet excavated material leaving and arriving at the site to prevent dust. Clean roads to the site of any material falling from haul trucks.

1.03 FINAL CLEANING

- A. At the completion of work and immediately prior to final inspection, clean the entire project site as follows:
 - 1. Clean, sweep, wash, and polish all work and equipment including finishes.
 - 2. Remove grease, dust, dirt, stains, labels, fingerprints, and other foreign materials from sight-exposed interior and exterior finished surfaces, polish surfaces.
 - 3. Repair, patch, and touch up marred surfaces to match adjacent surfaces.
 - 4. Broom clean paved surfaces; rake clean landscaped areas.
 - 5. Remove from the site all temporary structures and all materials, equipment, and appurtenances not required as a part of, or appurtenant to, the completed work.

END OF SECTION

SECTION 01730 OPERATION AND MAINTENANCE MANUALS

1.01 GENERAL

- A. Upon request of the District, the Contractor shall submit one electronic and three hard copies of all manufacturer's operation and maintenance manuals and data pertinent to equipment supplied for the project. Prepare and organize the material in three-ring binders with divider tabs and labels. Include a table of contents. These three manuals are in addition to any information submitted as shop drawings.

1.02 SUBMITTALS

- A. All submittals shall be transmitted to the District utilizing the District's standard form. Submittals shall include:
 - 1. List of equipment furnished for project with name, address, and telephone number of vendor.
 - 2. List of serial numbers of equipment furnished.
 - 3. Equipment data sheet describing function of equipment.
 - 4. A copy of shop drawings for mechanical, electrical, and instrument equipment in final form.
 - 5. Installation or application instructions
 - 6. Manufacturer's operation and maintenance instructions and parts lists.

END OF SECTION

SECTION 02222 PROTECTING EXISTING UNDERGROUND UTILITIES

PART 1 - GENERAL

1.01 DESCRIPTION

- A. This section includes materials and procedures for protecting existing underground utilities.
 - 1. Related works specified elsewhere: Trenching, backfilling, and compacting: 02223

PART 2 - MATERIALS

2.01 REPLACEMENT IN KIND

- A. Except as indicated below or as specifically authorized by the Owner's Representative, reconstruct utilities with new material of the same size, type, and quality as that removed.

PART 3 - EXECUTION

3.01 GENERAL

- A. Replace in kind street improvements, such as curbs and gutters, barricades, traffic islands, signalization, fences, signs, etc., that are cut, removed, damaged, or otherwise disturbed by the construction.
- B. Where utilities are parallel to or cross the construction but do not conflict with the permanent work to be constructed, follow the procedures given below and as indicated in the drawings. Notify the utility owner 48 hours in advance of the crossing construction and coordinate the construction schedule with the utility owner's requirements. For utility crossings not shown in the drawings, refer to the General Provisions and the instructions of the Owner's Representative for guidance.
- C. Determine the true location and depth of utilities and service connections (potholing) which may be affected by or affect the work. Determine the type, material, and condition of these utilities. In order to provide sufficient lead time to resolve unforeseen conflicts, order materials and take appropriate measures to ensure that there is no delay in work.

3.02 PROCEDURES

- A. Protect in Place: Protect utilities in place, unless abandoned, and maintain the utility in service, unless otherwise specified in the drawings or in the specifications.
- B. Cut and Plug Ends: Cut abandoned utility lines and plug the ends. Plug buried pipes 6-inches and larger to be abandoned. Pipes 6-inches and larger shall be slurry filled. Cap waterlines with a cast-iron cap or install a 3-foot-long concrete plug. Dispose of the cut pipe as unsuitable material.
- C. Remove and Reconstruct: Provide temporary service for the disconnected utility.

3.03 COMPACTION

- A. Utilities Protected in Place: Backfill and compact under and around the utility so that no voids are left.
- B. Utilities Reconstructed: Prior to replacement of the utility, backfill the trench and compact to an elevation 1 foot above the top of the ends of the utility if slurry is not utilized. Excavate a cross trench of the proper width for the utility and lay, backfill, and compact.
- C. Alternative Construction--Sand Slurry: Sand slurry consisting of one sack (94 pounds) of Portland cement per cubic yard of sand and sufficient moisture for workability may be substituted for other backfill materials to aid in reducing compaction difficulties. Submit specific methods and procedures for the review of the Owner's Representative prior to construction.

3.04 THRUST BLOCKS ON WATERLINES

- A. The Contractor's attention is called to thrust blocks for waterlines throughout the project whose thrust is in the direction of the new excavation and, therefore, may be affected by the construction. These waterlines are owned and operated by the Owner or by others. Protect thrust blocks in place or shore to resist the thrust and reconstruct. If the thrust blocks are exposed or rendered to be ineffective in the opinion of the Owner's Representative, reconstruct them to bear against firm unexcavated or backfill material. Provide firm support by backfilling that portion of the trench for a distance of 2 feet on each side of the thrust block to be reconstructed from the pipe bedding to the pavement subgrade, with either one sack sand slurry, or the native material compacted to a relative compaction of 95%. Then excavate the backfill material for construction of the thrust block. Test compaction of the backfill material before pouring any concrete thrust block. Use Class A concrete for reconstruction per Section 03000.

3.05 ADJACENT PARALLEL UTILITIES

- A. Protect these utilities from any disturbances and repair the lines and associated vaults and appurtenances if they are damaged in any way.

END OF SECTION

SECTION 02223 TRENCHING, BACKFILLING, AND COMPACTING

PART 1 - GENERAL

1.01 DESCRIPTION

- A. This section includes materials, testing, and installation for trench excavation, backfilling, and compacting.
 - 1. Related work specified elsewhere:
 - a. Asphalt Concrete Paving: 02513
 - b. General Concrete Construction: 03000
 - c. Pressure Testing of Piping: 15044
 - d. Cathodic Protection and Joint Bonding: 16640

1.02 SUBMITTALS

- A. Submit 1 electronic and 1 hard copy of a report from a testing laboratory verifying that the backfill material contains less than 1% asbestos by weight or volume and conforms to the specified gradations or characteristics for pea gravel, granular material, imported sand, rock refill for foundation stabilization, and water.
- B. Submit method of compaction in pipe zone including removal sequence of shoring where used.

1.03 TESTING FOR COMPACTION

- A. The Owner will test for compaction as described below.
- B. Determine the density of soil in place by the sand cone method, ASTM D 1556 or by nuclear methods, ASTM D 2922 and D 3017.
- C. Determine laboratory moisture-density relations of soils by ASTM D 1557.
- D. Determine the relative density of cohesionless soils by ASTM D 4253 and D 4254.
- E. Sample backfill materials by ASTM D 75.
- F. "Relative compaction" is the ratio, expressed as a percentage, of the in place dry density to the laboratory maximum dry density.
- G. Where compaction tests indicate a failure to meet the specified compaction, the Owner will order additional tests at the cost of the Contractor in each direction until the extent of the failing area is identified. Rework the entire failed area until the specified compaction has been achieved.

1.04 PAVEMENT ZONE

- A. The pavement zone includes the asphalt concrete and aggregate base pavement section placed over the trench backfill.

1.05 TRENCH ZONE

- A. The trench zone includes the portion of the trench from the top of the pipe zone to the bottom of the street pavement zone in paved areas or to the existing surface in unpaved areas.

1.06 PIPE BEDDING ZONE

- A. The Pipe Zone shall include the full width of trench from the bottom of the trench, 6-inches minimum below pipe or greater if trench bottom is unsuitable, or conduit to a horizontal level above the top of the pipe, as specified below. Where multiple pipes or conduits are placed in the same trench, the pipe zone shall extend from the bottom of the lowest pipes to a horizontal level above the top of the highest or topmost pipe. Thickness of pipe zone above the highest top of pipe shall be as follows unless otherwise shown in the drawings or otherwise described in the specifications for the particular type of pipe installed.

<u>Pipe Diameter</u>	<u>Thickness of Pipe Zone Above Top of Pipe</u>
4 – 27 inches	12 inches

- B. The pipe base or bedding shall be defined as a layer of material immediately below the bottom of the pipe or conduit and extending over the full trench width in which the pipe is bedded. Thickness of pipe base shall be as follows unless otherwise shown in the drawings or otherwise described in the specifications for the particular type of pipe installed.

<u>Pipe Diameter</u>	<u>Thickness of Pipe Base</u>
4 -27 inches	6 inches

PART 2 – MATERIALS

2.01 GRANULAR MATERIALS FOR BACKFILL

- A. Street and Trench Zones
 - 1. Unless otherwise noted on plans, granular material or granular soil for backfill used above the pipe zone shall be lean bank-run or pit-run gravel, or native soil. The maximum particle size shall be 2 inches. A maximum of 10% shall pass a No 200 sieve.

2.02 NATIVE EARTH BACKFILL

- A. Native earth backfill must be approved by the agency having jurisdiction. For street and trench zones, native earth backfill used above the pipe zone shall be excavated fine-grained materials free from roots, debris, and rocks larger than 3 inches, asbestos, organic matter, clods, clay balls, broken pavement, and other deleterious materials.

2.03 IMPORTED SAND

- A. For pipe zones and pipe bases, imported sand used in the pipe zone for the pipe base shall meet the following gradation:

<u>Sieve Size</u>	<u>Percent Passing By Weight</u>
3/8 inch	100
No. 4	75 - 100
No. 30	12 - 50
No. 100	5 - 20
No. 200	0 - 10

Minimum sand equivalent shall be 30 for natural imported material and shall be 40 for screened recycled materials per ASTM D 2419.

2.04 GRAVEL AND CRUSHED ROCK

- A. Unless otherwise noted in plans, for meter box base, gravel or crushed rock material shall contain less than 1% asbestos by weight or volume and conform to the Standard Specifications for Public Works Construction, Section 200-1.2, 1-inch nominal size.

2.05 SAND-CEMENT SLURRY BACKFILL – PIPE ZONE

- A. Unless otherwise noted in plans, for pipe zone, cement slurry backfill shall consist of one sack (94 pounds) of Type I or II Portland cement added per cubic yard of imported sand and sufficient water for workability.

2.06 ROCK REFILL FOR FOUNDATION STABILIZATION

- A. For foundation stabilization, rock refill shall be crushed or natural rock containing less than 1% asbestos by weight or volume, having the following gradation:

<u>Sieve Size</u>	<u>Percent Passing By Weight</u>
3 inches	100
1 – ½ inches	70 – 100
¾ inch	60 - 100
No. 4	25 - 55
No. 30	10 – 30
No. 200	0 - 10

2.07 CONCRETE FOR PIPE ENCASUREMENT AND THRUST BLOCKS

- A. Concrete for pipe encasement and thrust blocks shall be Class A per Section 03000, unless otherwise shown in the drawings.
- B. See the details in the Standard Drawings for thrust block sizes.
- C. Dimensions of thrust blocks for pipes smaller than 6 inches shall be the same as the dimensions shown for 6-inch pipe.

2.08 WATER FOR COMPACTION

- A. Water used in compaction shall have a maximum chloride concentration of 500 mg/L, a maximum sulfate concentration of 500 mg/L and shall have a pH of 7.0 to 9.0. Water shall be free of organic materials injurious to the pipe coatings.

PART 3 - EXECUTION

3.01 COMPACTION REQUIREMENTS

- A. Unless otherwise shown in the drawings or otherwise described in the specifications for the particular type of pipe installed, relative compaction in pipe trenches shall be as follows:
 1. Pipe zone--90% relative compaction.
 2. Backfill in trench zone not beneath paving--90% relative compaction.
 3. Backfill beneath pavement in street pavement zone in paved areas--95% relative compaction.
 4. Backfill in street pavement zone in paved areas--95% relative compaction.

5. Rock refill for foundation stabilization--80% relative density.

3.02 MATERIAL REPLACEMENT

- A. Remove and replace any trenching and backfilling material which does not meet the specifications, at the Contractor's expense.

3.03 SLOPING, SHEETING, SHORING, AND BRACING OF TRENCHES

- A. Trenches shall have sloping, sheeting, shoring, and bracing conforming with 29CFR1926, Subpart P--Excavations, CAL/OSHA requirements, and the General Conditions. The Contractor shall provide tables and charts, including tabulated data, approved by a registered professional engineer to design and construct a protective system.

3.04 SIDEWALK, PAVEMENT, AND CURB REMOVAL

- A. Cut bituminous and concrete pavements regardless of the thickness and curbs and sidewalks prior to excavation of the trenches with a pavement saw or pavement cutter. Width of the pavement cut shall be at least equal to the required width of the trench at ground surface. Haul pavement and concrete materials from the site. Do not use for trench backfill.

3.05 TRENCH WIDTHS

- A. Trench widths in the pipe zone shall be as shown in the drawings. If no details are shown, maximum width shall be 18 inches greater than the pipe outside diameter. Comply with 29CFR Part 1926 Subpart P--Excavations.

3.06 TRENCH EXCAVATION

- A. Excavate the trench to the lines and grades shown in the drawings with allowance for pipe thickness, sheeting and shoring if used, and for pipe base or special bedding. If the trench is excavated below the required grade, refill any part of the trench excavated below the grade at no additional cost to the Owner with imported sand or foundation stabilization material. Place the refilling material over the full width of trench in compacted layers not exceeding 6 inches deep to the established grade with allowance for the pipe base or special bedding.
- B. Construct trenches in rock by removing rock to a minimum of 6 inches below bottom of pipe and backfilling with imported sand or foundation stabilization material.

3.07 DEWATERING

- A. Provide and maintain means and devices to remove and dispose of all water entering the trench excavation during the time the trench is being prepared for the pipelaying, during the laying of the pipe, and until the backfill at the pipe bedding zone has been completed. These provisions shall apply at all times. Dispose of the water in a manner to prevent

damage to adjacent property and in accordance with regulatory agency requirements. Do not drain trench water through the pipeline under construction.

3.08 LOCATION OF EXCAVATED MATERIAL

- A. During trench excavation, place the excavated material only within the working areas shown in the drawings. Do not obstruct any roadways or streets. Conform to federal, state, and local codes governing the safe loading of trenches with excavated material.

3.09 LENGTH OF OPEN TRENCH

- A. Limit the length of open trench to 500 feet in advance of pipelaying or amount of pipe installed in one working day. Backfilling and temporary or first layer paving shall be completed so that not more than 500 feet of trench is open in the rear of pipe laying.

3.10 TRENCH EXCAVATION IN BACKFILL AND EMBANKMENT AREAS

- A. Construct trench excavation for pipe, pipes, or conduit in backfill or embankment areas in accordance with the following procedures:
 1. Construct and compact the embankment to an elevation of 1 foot minimum over the top of the largest pipe or conduit to be installed.
 2. Excavate trench in the compacted backfill or embankment. Place pipe base material, install pipe or conduit, and backfill with pipe zone material. Compact backfill above the pipe zone to the same relative compaction as the adjacent embankment.

3.11 FOUNDATION STABILIZATION

- A. After the required excavation has been completed, the District Inspector will inspect the exposed subgrade to determine the need for any additional excavation. It is the intent that additional excavation be conducted in all areas within the influence of the pipeline where unacceptable materials exist at the exposed subgrade. Over-excavation shall include the removal of all such unacceptable material that exists directly beneath the pipeline to a width 18 inches greater than the pipe outside diameter and to the depth required. Backfill the trench to subgrade of pipe base with rock refill material for foundation stabilization. Place the foundation stabilization material over the full width of the trench and compact in layers not exceeding 6 inches deep to the required grade.

3.12 INSTALLING BURIED PIPING

- A. Backfill per the detailed piping specification for the particular type of pipe and per the following:
 1. Pipe zone and pipe base material shall be:

Type of Pipe

Type of Backfill Material for Pipe
Zone and Pipe Base

Ductile Iron

Imported Sand

Polyvinyl Chloride

Imported Sand

2. Handle pipe in such a manner as to avoid damage to the pipe. Do not drop or dump pipe into trenches under any circumstances.
3. Inspect each pipe and fitting before lowering the buried pipe or fitting into the trench. Inspect the interior and exterior protective coatings. Patch damaged areas in the field with material recommended by the protective coating manufacturer. Clean ends of pipe thoroughly. Remove foreign matter and dirt from inside of pipe and keep clean during and after installation.
4. Grade the bottom of the trench to the line and grade to which the pipe is to be laid, with allowance for pipe thickness. Remove hard spots that would prevent a uniform thickness of bedding. Place the specified thickness of pipe base material over the full width of trench. Grade the top of the pipe base ahead of the pipelaying to provide firm, continuous, uniform support along the full length of pipe, and compact to the relative compaction specified herein. Before laying each section of the pipe, check the grade with a straightedge and correct any irregularities.
5. Excavate bell holes at each joint to permit proper assembly and inspection of the entire joint. Fill the area excavated for the joints with the bedding material specified or detailed in the drawings or use in the pipe zone.
6. When installing pipe, do not deviate more than 1 inch from line or 1/4 inch from grade. Measure elevation at the pipe invert. Pipe should be installed per manufacturer's recommendations and District specifications for each pipe material.
7. After pipe has been bedded, place pipe zone material simultaneously on both sides of the pipe, in maximum 6-inch lifts, keeping the level of backfill the same on each side. Carefully place the material around the pipe so that the pipe barrel is completely supported and that no voids or uncompacted areas are left beneath the pipe. Use particular care in placing material on the underside of the pipe to prevent lateral movement during subsequent backfilling.
8. Compact each lift to the relative compaction specified herein.
9. Push the backfill material carefully onto the backfill previously placed in the pipe zone. Do not permit free fall of the material until at least 2 feet of cover is provided over the top of the pipe. Do not drop sharp, heavy pieces of material directly onto the pipe or the tamped material around the pipe. Do not operate heavy equipment over the pipe until at least 3 feet of backfill has been placed and compacted over the pipe.

10. When the pipelaying is not in progress, close the open ends of pipe. Do not allow trench water, animals, or foreign material to enter the pipe.
11. Remove and dispose of all water entering the trench during the process of pipelaying. Keep the trench dry until the pipelaying and jointing are completed.

3.13 BACKFILL COMPACTION

- A. Compact per the detailed piping specification for the particular type of pipe and per the following:
 1. Compact trench backfill to the specified relative compaction. Compact by using mechanical compaction or hand tamping. Do not use high impact hammer-type equipment except where the pipe manufacturer warrants in writing that such use will not damage the pipe.
 2. Compact material placed within 12 inches of the outer surface of the pipe by hand tamping only.
 3. Do not use any axle-driven or tractor-drawn compaction equipment within 5 feet of building walls, foundations, and other structures.

END OF SECTION

SECTION 02315 JACKED STEEL CASING

PART 1 - GENERAL

1.01 DESCRIPTION

- A. This section includes materials and installation for tunneling by jacked steel casing method for highway crossings and other shallow depth tunnels.
- B. Related Work Specified Elsewhere
 - 1. Trenching, Backfilling, and Compacting: 02223
 - 2. General Concrete Construction: 03000
 - 3. Cathodic Protection and Joint Bonding: 16640

1.02 SUBMITTALS

- A. Submit shop drawings in accordance with the General Conditions.
- B. Submit Manufacturer's mill certification sheet listing diameter, thickness, and class of steel casing.
- C. Submit location of approach trench, jacking pit, tunnel and receiving pit.
- D. Submit schedule and method of tunnel construction. Include also approach trench backfill and pipe installation and backfill.
- E. Submit engineered stamped and signed shoring plan for jacking and receiving pits.
- F. Submit welding procedure specifications (WPS) and procedure qualification records (PQR) for each welding process and welder qualification records (WQR) for each welder and welding operator. Submit bend and tensile test coupons concurrently with welder qualification and procedure qualification records. Welding procedures shall be required for welds for pipe cylinders, casing joint welds, and grout coupling connections.

1.03 TUNNEL CLASSIFICATION

- A. The Contractor shall obtain from the California Division of Industrial Safety a classification for each bore. It shall be the Contractor's responsibility to post the classification at the site and see that the work is done in conformance with the state requirements. It shall also be the Contractor's responsibility to call the required safety meeting with representatives from the State Division of Industrial Safety prior to beginning of construction of each bore.

1.04 SCHEDULING

- A. If the pipeline is not installed within the casing as a continuous operation following completion of jacking, then bulkhead the portals and backfill the approach trenches and later reopen them for pipe installation.

1.05 JURISDICTION

- A. Comply with the applicable regulations of 29CFR 1926, Subpart S, "Underground Construction, Caisson, Cofferdams, and Compressed Air" as amended.
- B. For casing pipe crossing under roadways, railroads, or other installations not within the jurisdiction of the Owner, the Contractor shall comply with regulations of said authority.
- C. Casing installations for railroads shall be as specified by the American Railway Engineering Association, Part 5, Section 5.2, "Specifications for Pipelines Conveying Non-Flammable Substances" or the agency having jurisdiction.

PART 2 – MATERIALS

2.01 STEEL CASING

- A. Fabrication of casing shall be in accordance with AWWA C200, as modified below. Casing material shall conform to ASTM A 283, Grade C; ASTM A 139, Grade B; or ASTM A 36. Obtain minimum diameter and wall thickness from the District's Standard Drawings. The Contractor may select a greater thickness and diameter to accommodate the method of work, loadings involved, the site and possible interferences. Provide 2-inch grout connections in the form of threaded couplings welded to the steel shell regularly spaced at 4 feet on centers at the top and bottom of the casing.
- B. Join casing sections by butt welding in the field. Prepare ends of casings for welding in accordance with the submitted welding procedure.

2.02 CASING SPACERS

- A. Casing spacers shall be bolt-on style with a shell made in two sections of Type 304 stainless steel. Connecting flanges shall be ribbed. The shell shall be lined with a PVC liner 0.090 inch thick with 85-90 durometer. Nuts and bolts shall be 18-8 stainless steel. Runners shall be made of ultra-high molecular weight polymer. Runners shall be supported by risers made of Type 304 stainless steel. The supports shall be welded to the shell, and all welds shall be passivated. Casing spacers shall be Cascade Waterworks Mfg Co, PSI, or equal.

2.03 CASING SEALS

- A. Casing seals shall be 1/8-inch-thick synthetic rubber, designed to fit snugly around pipe and casing. Casing seals shall be one piece with no field seams. Bands and hardware for attachment to pipe and casing O.D. shall be stainless steel.

2.04 GROUT

- A. Lean grout shall consist of one part Portland cement, four parts sand, and sufficient water to produce a workable mixture. Sand for grout to be placed outside the casing shall be of such fineness that 100% will pass a No. 8 sieve and not less than 35% will pass a No. 50 sieve.

2.05 SAND BACKFILL

- A. Sand shall be dry (water content not more than 6% nor less than 3%), free from organic matter, and containing not over 5% by weight of deleterious substances. It shall be hard, dense, durable, clean, sharp, and graded evenly from fine to coarse as follows:

<u>Sieve Size</u>	<u>Percent by Weight</u>
Passing 3/8 inch	100
Passing No. 4	97 – 100
Passing No. 8	79 – 85
Passing No. 16	60 - 78
Passing No. 30	36 – 47
Passing No. 50	10 – 20
Passing No. 100	0 – 4

- B. Sand shall have a fineness modulus per ASTM C136 of between 2.70 and 3.30, inclusive.

PART 3 – EXECUTION

3.01 SECTION SHIELD OR JACKING HEAD

- A. Fit a sectional shield or steel jacking head to the leading section of the casing to extend around the outer surface of the upper two-thirds of the casing and project at least 18 inches beyond the driving end of the casing, but do not protrude more than 1/2 inch outside of the outer casing surface. Anchor the head to prevent any wobble or alignment variation during the jacking operation. To avoid causing a collapse of ground outside the casing, carry out excavation entirely within the jacking head and not in advance of the head.

3.02 JACKING PIT

- A. Place in the approach trench or jacking pit and firmly bed on the required line and grade guide rails, structural steel, or concrete cradle of sufficient length to provide accurate control of jacking alignment. Provide adequate space to permit the insertion of the lengths of casing to be jacked. Anchor the guide rails and structural steel sections to ensure action

of the jacks in line with the axis of the casing. Interpose between the jacks and the end of the casing a bearing block consisting of a timber or structural steel framework constructed to provide uniform end bearing over the perimeter of the casing and distribute the jacking pressure evenly.

3.03 CONTROL OF ALIGNMENT AND GRADE

- A. Control the application of jacking pressure and excavation of material ahead of the casing as it advances to prevent the casing from becoming earthbound or deviating from required line and grade. Do not encroach upon the minimum annular space detailed. Restrict the excavation of material to the least clearance necessary to prevent binding in order to avoid causing a collapse of ground and consequent settlement or possible damage to overlying structures.

3.04 EXTERIOR GROUTING

- A. Immediately after completion of the jacking or boring operation, inject lean grout through the grout connections in such a manner as to completely fill all voids outside the casing pipe resulting from the jacking or boring operation. Control grout pressure to avoid deformation of the casing, avoid damaging or plugging of adjacent subdrains, and avoid movement of the surrounding ground. After completion of grouting, close the grout connections with malleable iron or cast-iron threaded plugs.

3.05 SAND BACKFILL

- A. After placement of the pipe within the casing, construct a permanent bulkhead at each end of the casing or use casing seals (PSI or equal), fill the intervening annular space between the pipe and the casing with sand, placed by a pneumatic gun.

3.06 CLOSING THE JACKING PIT

- A. Seal the end of the casing with casing seals. After jacking equipment and muck from the tunnel have been removed from the approach trench or jacking pit, prepare the bottom of the jacking pit as a pipe foundation. Remove loose and disturbed material below pipe grade to undisturbed earth and recompact the material in accordance with Section 02223.

3.07 ALIGNMENT

- A. The variation in the field position of the casing from the line and grade as indicated in the drawings shall be limited to 1 inch in lateral alignment and 1/4 inch in vertical grade providing that, in the case of gravity flow pipes, the final grade of the flow line shall be in the indicated direction.

END OF SECTION

SECTION 02513 ASPHALT CONCRETE PAVING

PART 1 – GENERAL

1.01 DESCRIPTION

- A. This section includes materials, testing, and installation of asphalt concrete pavement, aggregate base course, herbicide, prime coat, tack coat, and seal coat outside the public right-of-way. Within the right-of way of city, county, or state streets or highways, work shall be in accordance with the requirements and to the satisfaction of the agency having jurisdiction.
- B. Related Work Specified Elsewhere
 - 1. Trenching, Backfilling and Compacting: 02223

1.02 SUBMITTALS

- A. Submit three copies of a report from a testing laboratory verifying that aggregate material contains less than 1% asbestos by weight or volume and conforms to the specified gradations or characteristics.

1.03 TESTING FOR COMPACTION

- A. See Section 02223

1.04 STANDARD SPECIFICATIONS

- A. Wherever reference is made to the State Specifications or Public Works Specifications such reference shall mean the State of California, Business, Transportation, and Housing Agency, Department of Transportation Standard Specifications, the latest edition, or Standard Specifications for Public Works Construction (SSPWC), the latest edition, respectively.

PART 2 - MATERIALS

2.01 ASPHALT CONCRETE PAVING

- A. Asphalt concrete paving shall conform to III-C2-AR-4000 as listed in Section 203-6 of the Public Works Specifications. The Performance Grade shall be PG 64-10 or PG 70-10, as determined by the District.

2.02 AGGREGATE BASE COURSE

- A. Aggregate base shall be crushed aggregate base as specified in Section 203-6 of the Public Works Specifications. Aggregate shall contain less than 1% asbestos by weight or volume.

2.03 PRIME COAT

- A. All areas to be paved shall receive prime coat. Prime coat shall be medium curing (MC-70) in accordance with Section 203-2 of the Public Works Specifications.

2.04 TACK COAT

- A. Tack coat shall conform with Section 302-5.4 of the Public Works Specifications and shall be either AR1000 paving asphalt or Grade SS-1h emulsified asphalt.

2.05 ASPHALT

- A. Asphalt shall be viscosity grade PG-64-10. Asphalt content in the pavement shall be 5.5% to 6.0%

2.06 AGGREGATE FOR ASPHALT CONCRETE

- A. Aggregate shall be in accordance with Section 203-6 of the Public Works Specifications.

2.07 SEAL COAT

- A. Seal coat shall be Type II emulsion-aggregate slurry per Section 203-5 of the Public Works Specifications.

2.08 REDWOOD HEADER

- A. Size of redwood headers shall be 2 inches by the depth of the asphalt concrete paving; minimum size shall be 2 inches by 4 inches. Wood shall be redwood and shall comply with Section 204-1 of the Public Works Specifications.

PART 3 - EXECUTION

3.01 PAVEMENT REMOVAL

- A. The pavement removal shall be as follows unless otherwise stated by agency having jurisdiction:
 1. Initially cut asphalt concrete pavement with pneumatic pavement cutter or other equipment at the limits of the excavation and remove the pavement. After backfilling the excavation, saw cut asphalt concrete pavement to a minimum depth of 2 inches at a point not less than 9 inches outside the limits of the excavation or the previous pavement cut, whichever is greater, and remove the additional pavement.
 2. Saw cut concrete pavement, including cross gutters, curbs and gutters, sidewalks, and driveways, to a minimum depth of 1-1/2 inches at a point 1 foot beyond the edge of the excavation and remove the pavement. The concrete pavement may initially be cut at the limits of the excavation by other methods prior to removal and

the saw cut made after backfilling the excavation. If the saw cut falls within 3 feet of a concrete joint or pavement edge, remove the concrete to the joint or edge.

3. Make arrangements for and dispose of the removed pavement.
4. Final pavement saw cuts shall be straight along both sides of trenches, parallel to the pipeline alignment, and provide clean, solid, vertical faces free from loose material. Saw cut and remove damaged or disturbed adjoining pavement. Saw cuts shall be parallel to the pipeline alignment or the roadway centerline or perpendicular to same.

3.02 PAVEMENT REPLACEMENT

- A. Backfill, compaction, and the permanent paving, except for the final asphalt surface course, shall be complete at all times to a point not to exceed 500 feet behind any working heading. The final asphalt surface course shall be governed by jurisdiction agency.
- B. The pavement replacement shall be as follows:
 1. AC pavement shall be replaced to a thickness one tenth foot greater than the original section or 6 inches, whichever is greater.
 2. Paving asphalt shall not be heated during its manufacture, storage, or during construction so as to cause formation of carbonized particles. At no time shall be the temperature be higher than 10°F below the actual flash point of the paving asphalt. Paving asphalt shall not be raised above 375 °F after loading into a tank car or truck for transport. The following table summarizes the temperature range for various grades of paving asphalt:

Asphalt Grade	Plant Mixing Temperature °F (°C)		Distribution Application Temperature °F (°C)	
	PG 70-10	300 (150)	350 (175)	285 (140)
PG 64-28	275 (135)	325 (160)	285 (140)	350 (175)
PG 64-16	275 (135)	325 (160)	285 (140)	350 (175)
PG 64-10	275 (135)	325 (160)	285 (140)	350 (175)

3.03 INSTALLATION

- A. Producing, hauling, placing, compacting, and finishing of asphalt concrete shall conform to Section 39 of the State Specifications. Apply seal coat to all paving except open asphalt concrete.

3.04 CONNECTIONS WITH EXISTING PAVEMENT

- A. Where new paving joins existing paving, grind the existing surfaces 12 inches back from the joint line so that these will be sufficient depth to provide a minimum of one tenth foot of asphalt concrete. Dispose of waste material offsite. Tack chipped areas prior to placing the asphalt concrete. Meet lines shall be straight and the edges vertical. Paint the edges of meet line cuts with liquid asphalt or emulsified asphalt prior to placing asphalt concrete. After placing the asphalt concrete, seal the meet line by painting with a liquid asphalt or emulsified asphalt and then immediately cover with clean, dry sand.

3.05 PREPARATION OF SUBGRADE

- A. Excavate and shape subgrade to depths required for placement of aggregate base and AC pavement such that grade and cross section shall match existing pavement. Compact subgrade in accordance with Section 02223. Remove all soft material disclosed by the compacting and replace with suitable material and recompact. The finished subgrade shall be within a tolerance of +/-0.08 of a foot of the grade and cross section shown and shall be smooth and free from irregularities and at the specified relative compaction. The subgrade shall be considered to extend over the full width of the base course.

3.06 INSTALLING REDWOOD HEADERS

- A. Provide redwood header at edges of paving except where paving is adjacent to concrete slabs, gutters, walks, existing paving, or structures.

3.07 PLACING AGGREGATE BASE COURSE

- A. Compact to 95% relative compaction. Install in accordance with Section 26 of the Caltrans Standard Specifications.

3.08 COMPACTION OF AGGREGATE BASE AND LEVELING COURSES

- A. Compaction and rolling shall begin at the outer edges of the surfacing and continue toward the center. Apply water uniformly throughout the material to provide moisture for obtaining the specified compaction. Compact each layer to the specified relative compaction before placing the next layer.

3.09 PLACING PRIME COAT

- A. Apply prime coat to the surface of the leveling course of aggregate base at the rate of 0.25 gallon per square yard per Section 39-4.02 in the State Specifications.

3.10 PLACING TACK COAT

- A. Apply tack coat on surfaces to receive finish pavement per Section 39-4.02 in the State Specifications. Apply tack coat to metal or concrete surfaces that will be in contact with the asphalt concrete paving.

3.11 PLACING ASPHALT PAVING

- A. Install in accordance with Section 39-6 in the Caltrans Standard Specifications.

3.12 COMPACTION OF ASPHALT CONCRETE PAVING

- A. Compact until roller marks are eliminated and a density of 92% minimum to 98% maximum has been attained per ASTM D 2041.

3.13 APPLYING SEAL COAT

- A. Apply seal coat at the rate of 0.05 to 0.10 gallon per square yard.

3.14 SURFACE TOLERANCE

- A. Finished grade shall not deviate more than 0.08 foot in elevation from the grade indicated in the drawings. Slopes shall not vary more than 1/4 inch in 10 feet from the slopes shown in the drawings.
- B. After paving has been installed and compacted, spray water over the entire paved area. Correct any areas where water collects and does not drain away.

END OF SECTION

SECTION 02667 HOT-TAP CONNECTIONS

PART 1 - GENERAL

1.01 DESCRIPTION

- A. This section includes materials and installation of hot-tap connections to existing buried ductile iron, steel, asbestos cement, and PVC (cast-iron O.D.) pipelines.
- B. Related Work Specified Elsewhere:
 - 1. Fusion-Bonded Epoxy Linings and Coatings: 09811
 - 2. Painting and Coating: 09900
 - 3. Manual, Check, and Process Valves: 15100
 - 4. Cathodic Protection and Joint Bonding: 16640

1.02 SUBMITTALS

- A. Submit shop drawings in accordance with the General Conditions.
- B. Submit manufacturer's catalog data for tapping sleeves. Show coatings.
- C. Submit shop drawing for design and fabrication of steel outlet connections to existing steel pipes.

PART 2 - MATERIALS

2.01 TAPPING SLEEVES FOR DUCTILE-IRON AND PVC (CAST-IRON O.D.) PIPES

- A. Tapping Sleeve for Ductile-Iron and PVC (Cast-Iron O.D.) Pipes: Mueller H-615 or equal. Tapping sleeve must be minimum one size smaller than main-line.
- B. Tapping Sleeve for Asbestos Cement Pipe: Mueller H-619 or equal.
- C. Pipe, fittings, and appurtenances made of dissimilar metals shall be isolated from each other.
- D. Pressure rating shall be at least 200 psi for piping 12 inches and smaller and at least 150 psi for piping 14 through 27 inches.

2.02 COATING FOR TAPPING SLEEVES

- A. Coat with epoxy per Section 09900, System No. 21 or fusion-bonded epoxy per Section 09811.

2.03 TAPPING GATE VALVES

- A. See Section 15100.

2.04 CONNECTIONS TO EXISTING STEEL PIPES

- A. Design of outlets with collars, wrappers, or crotch plates must be AWWA M11 and ASME B31.1 compliant. Weld a fabricated steel collar with nozzle to the existing pipe. An entire wrapper plate may be substituted for the collar. Steel material shall have a minimum yield stress of 30,000 psi.

PART 3 - EXECUTION

3.01 VERIFICATION OF PIPE O.D. PRIOR TO INSTALLATION

- A. Excavate the points of connection prior to submittal of shop drawings. Verify O.D. prior to ordering materials.

3.02 INSTALLING CONNECTIONS TO EXISTING STEEL PIPES

- A. Remove any existing coating to a point 3 inches beyond the area of the pipe which will be covered by the collar or wrapper.
- B. Weld the collar to the pipe shell. Weld the entire circumference of the collar.
- C. After installation, coat with fast setting mortar, Speedcrete or equal, per Section 09900, System No. 21.

END OF SECTION

SECTION 03000 GENERAL CONCRETE CONSTRUCTION

PART 1 - GENERAL

1.01 DESCRIPTION

- A. This section includes materials, installation, and testing of formwork, reinforcing steel, joints, concrete, and finishing and curing for general concrete construction.
- B. Related Work Specified Elsewhere
 - 1. Painting and Coating: 09900

1.02 SUBMITTALS

- A. Submit shop drawings in accordance with the General Conditions.
- B. Submit mill test certificates identifying chemical and physical analyses of each load of reinforcing steel delivered. If mill test reports are unavailable and the quantity of steel for a structure exceeds 5 tons, provide a laboratory test to prove conformance with the specified ASTM standard.
- C. Submit reinforcing bending lists and placing drawings for all reinforcing. Placing drawings shall indicate all openings (mechanical, electrical, equipment, and architectural) including additional reinforcing at openings and corner bar arrangements at intersecting beams, walls, and footings indicated in the typical detail and structural drawings. Placing drawings shall be coordinated with the concrete placing schedule. Each bending list and placing drawing submitted shall be complete for each major element of a structure (grade slabs, footings, walls, deck, floor, or roof slabs) including dowels and corner bars. Furnishing such lists shall not be construed that the lists will be reviewed for accuracy. The Contractor shall be wholly and completely responsible for the accuracy of the lists and for furnishing and placing reinforcing steel in accordance with the details shown on the plans and as specified.
- D. Submit concrete mix design at least 15 days before placing concrete.
- E. Submit 1 electronic and 3 hard copies of a report from a testing laboratory verifying that aggregate material contains less than 1% asbestos by weight or volume and conforms to the specified gradations or characteristics.

PART 2 - MATERIALS

2.01 FORMWORK

- A. Design forms according to ACI 347.
- B. Class I Forms: Use steel forms, ply form, or smooth-surface plywood 3/4 inch minimum thickness for straight surfaces and 1/2 inch minimum thickness for curved surfaces.

- C. Class II Forms: Use plywood in good condition, metal, or smooth-planed boards free from large or loose knots with tongue and groove or ship lap joints. Forms shall be oiled.
- D. Class II forms may be used for exterior concrete surfaces which are 1 foot or more below finished grade. Use Class I forms for all other surfaces.

2.02 BOND BREAKER

- A. Bond breaker shall be a non-staining type which will provide a positive bond prevention, such as Williams Tilt-Up Compound, as manufactured by Williams Distributors, Inc., Seattle, Washington; Silcoseal 77, as manufactured by SCA Construction Supply Division, Superior Concrete Accessories, Franklin Park, Illinois; or equal.

2.03 FORM RELEASE AGENT

- A. Form release agent shall effectively prevent absorption of moisture and prevent bond with the concrete. Agent shall be non-staining and nontoxic after 30 days.
- B. For steel forms, release agent shall prevent discoloration of the concrete due to rust.

2.04 REINFORCING STEEL

- A. Reinforcement shall conform to ASTM A 615 or A 706, Grade 60.
- B. Fabricate reinforcing in accordance with the current edition of the Manual of Standard Practice, published by the Concrete Reinforcing Steel Institute. Bend reinforcing steel cold.
- C. Deliver reinforcing steel to the site bundled and tagged with identifying tags.

2.05 WELDED WIRE FABRIC

- A. Welded wire fabric shall conform to ASTM A 185.

2.06 TIE WIRE

- A. Tie wire shall be 16 gauge minimum, black, soft annealed.

2.07 BAR SUPPORTS

- A. Bar supports in beams and slabs exposed to view after form stripping shall be galvanized and plastic coated. Use concrete supports for reinforcing in concrete placed on grade.

2.08 CEMENT

- A. Cement shall conform to ASTM C 150, Type II/IV, with maximum tricalcium aluminate not to exceed 8%. The maximum percent alkalis shall not exceed 6%.

2.09 AGGREGATES

- A. Aggregates shall comply with ASTM C 33 and shall contain less than 1% asbestos by weight or volume and be free from any substances that will react with the cement alkalis.

2.10 COLOR ADDITIVE FOR EXTERIOR ELECTRICAL DUCT ENCASUREMENT

- A. For exterior electrical duct concrete encasements, use a color additive for identification purposes: brick red "Colorful," as manufactured by Owl Manufacturing Company, Arcadia, California; coral red "Chromix C-22," as manufactured by L. M. Scofield Company, Los Angeles, California; or equal. Add the color additive while the concrete is being mixed using the quantity per cubic yard of concrete recommended by the manufacturer for the class of concrete indicated.

2.11 CONCRETE ADMIXTURES

- A. Concrete shall contain an air-entraining admixture. Admixture shall conform to ASTM C 260, except it shall be nontoxic after 30 days and shall contain no chlorides. Admixtures shall be Master Builders MB-AE 90, Sika AER (Sikamix 104), or equal.
- B. Concrete shall contain a water-reducing admixture. The admixture shall conform to ASTM C 494, Type A, and contain no chlorides, shall be nontoxic after 30 days, and shall be compatible with the air-entraining admixtures. The amount of admixture added to the concrete shall be in accordance with the manufacturer's recommendations. Admixtures shall be Master Builders Pozzolith polymer-type normal setting, Plastocrete 161 Normal Set, Sika Chemical Corporation, or equal.
- C. Do not use any admixture that contains chlorides or other corrosive elements in any concrete.

2.12 GROUT

- A. Non-shrink grout shall conform to the Corps of Engineers Specification for Non-shrink Grout, CRD-C621-83, and to these specifications. Use a non-gas-liberating type, cement base, premixed product requiring only the addition of water for the required consistency. Grout shall be UPCON High Flow, Master Flow 928, or equal. Components shall be inorganic.
- B. Ordinary type grout (dry pack) shall consist of one part Portland cement to two parts sand (100% passing a No. 8 sieve). Add sufficient water to form a damp formable consistency.
- C. Expansive Grout: Premixed, cementitious mixture with a minimum 28-day strength of 3,500 psi. Provide air-entraining content as recommended by the manufacturer.
- D. Epoxy Grout:
 - 1. Mix the two components of epoxy bonding compound in compliance with the manufacturer's instructions.

2. Use sand that is oven dry and meets the following gradation requirements for epoxy grout:

Sieve Size	No. 8	No. 50	No. 100
% Passing	100	30 ±15	5 ±5

2.13 MORTAR

- A. Mortar used for repair of concrete shall be made of the same materials as used for concrete, except that the coarse aggregate shall be omitted, and the mortar shall consist of not more than one part cement to two and one-half parts sand by damp loose volume. The quantity of mixing water shall be no more than necessary for handling and placing.

2.14 BONDING COMPOUND

- A. Epoxy bonding compound shall be Sikadur 32 Hi-Mod, Sika Chemical Corporation, Lyndhurst, New Jersey; Euco Epoxy 452 by Euclid Chemical Company; or equal.
- B. Non-epoxy bonding compound shall be Weldcrete by Larsen Products Corp., Link by Sta-Dry Manufacturing Corp., Euco Weld by Euclid Chemical Co, or Equivalent. The compound shall be resettable for up to two weeks.

2.15 CONCRETE MIX DESIGN

- A. Conform to ASTM C 94, except as modified by these specifications.
- B. Air content as determined by ASTM C 231 shall be 4% ±1%.
- C. Maximum water-cement ratio for Class A concrete = 0.45 by weight.
- D. Use classes of concrete as described in the following table:

Class	Type of Work	28-Day Compressive Strength (in psi)	Minimum Cement Content (in lbs per C.Y.)
A	Concrete fill at cradle, thrust blocks, supports across pipe trenches, and reinforced pipe encasement.	4,000	564
B	Pavement	3,000	500
C	Floor grout and miscellaneous unreinforced concrete.	2,000	376

- E. The District shall measure slump in accordance with ASTM C 143. Slump shall be as follows:

Slab on grade or heavy sections wider (in plan view) than 3 feet	3 inches maximum
Footings, walls, suspended slabs, beams, and columns	4 inches maximum
Pavement	2 inches maximum
Floor grout	4 inches maximum

- F. Aggregate size shall be 3/4-inch maximum for slabs and sections 8 inches thick and less. Aggregate size shall be 1-inch maximum for slabs and sections greater than 8 inches and smaller than 17 inches. Aggregate size shall be 1-1/2 inches maximum for all larger slabs and sections. Aggregate size for floor grout shall be maximum 3/8 inch.
- G. Combined aggregate grading shall be as shown in the following table:

	Maximum Aggregate Size			
	1 1/2"	1"	3/4"	3/8"
Aggregate Grade per ASTM C33	467	57	67	8

- H. Mix design for pumped concrete shall produce a plastic and workable mix. The percentage of sand in the mix shall be based on the void content of the coarse aggregate.

2.16 CURING COMPOUND

- A. Curing compound shall conform to ASTM C 309, Type 2, Class A.
- B. Curing compound shall be compatible with required finishes and coatings and shall meet the State of California Clean Air Quality Standards which limit the quantity of volatile organic compounds.

2.17 MATS, PAPER, AND SHEETING FOR CURING

- A. Burlap mats shall conform to AASHTO Specification M182.
- B. Sisal-kraft paper and polyethylene sheets shall conform to ASTM C171.

PART 3 - EXECUTION

3.01 HAULING TIME REQUIREMENTS

- A. In no case shall the time between the time when the concrete is batched and it is placed exceed 90 minutes. When haul time is excessive, truck-transported, dry-batched concrete shall be used and mixed on the jobsite. Partially hardened concrete shall not be retempered

3.02 FORM TOLERANCES

- A. Failure of the forms to produce the specified concrete surface and surface tolerance shall be grounds for rejection of the concrete work. Rejected work shall be repaired or replaced at no additional cost to the Owner.
- B. The following table indicates tolerances or allowable variations from dimensions or positions of structural concrete work:

	Maximum Tolerance (inch)
Sleeves and inserts	+1/4 -1/4
Projected ends of anchors	+1/4 -0.0
Anchor bolt setting	+1/4 -1/4
Finished concrete, all locations	+1/4 -1/4 in 10 feet
	Max ±1-inch in total length

The planes or axes from which the above tolerances are to be measured shall be as follows:

Sleeves and inserts:	Centerline of sleeve or insert.
Projected ends of anchors:	Plane perpendicular to the end of the anchor as located in the drawings.
Anchor bolt setting:	Centerline of anchor bolt.
Finish concrete:	The concrete surface as defined in the drawings.

Where equipment is to be installed, comply with manufacturer's tolerances if more restrictive than above.

3.03 FORM SURFACE PREPARATION

- A. Clean form surfaces to be in contact with concrete of foreign material prior to installation.
- B. Coat form surfaces in contact with concrete with a release agent prior to form installation.

3.04 FORM REUSE

- A. Reuse only forms which provide a uniform surface texture on exposed concrete surfaces. Apply light sanding or other surface treatment between uses for uniform texture. Plug unused tie rod holes with corks, shave flush, and sand the concrete surface side. Do not patch forms other than filling tie rod holes, except in the case of Class II forms. Do not use metal patching discs on Class I forms.

3.05 REMOVAL OF FORMS

- A. Forms and shoring for elevated structural slabs or beams shall remain in place until the concrete has reached a compressive strength equal to the specified 28-day compressive strength as determined by test cylinders. Do not remove supports and re-shore. The following table indicates the minimum allowable time after the last cast concrete is placed before forms, shoring, or wall bracing may be removed:

Sides of footings and encasements	24 hours
Slabs, beams, and girders	10 days (forms only)
Shoring for elevated slabs, beams, and girders	Until concrete strength reaches specified 28-day strength
Wall bracing	Until top or roof slab concrete reaches specified 28-day strength

- B. Do not remove forms from concrete which has been placed with outside air temperature below 50°F without first determining if the concrete has properly set without regard for time. Do not apply heavy loading on green concrete. Immediately after forms are removed, the surface of the concrete shall be carefully examined and any irregularities in the surface shall be repaired and finished as specified.

3.06 FORMED OPENINGS

- A. Openings shall be of sufficient size to permit final alignment of pipes or other items without deflection or offsets of any kind. Allow space for packing where items pass through the wall to ensure watertightness. Provide openings with continuous keyways and water stops. Provide a slight flare to facilitate grouting and the escape of entrained air during grouting. Provide formed openings with reinforcement as indicated in the typical structural details. Reinforcing shall be at least 2 inches clear from the opening surfaces and encased items.

3.07 EMBEDDED ITEMS

- A. Set anchor bolts and other embedded items accurately and hold securely in position until the concrete is placed and set. Check all special castings, channels, or other metal parts that are to be embedded in the concrete prior to and again after concreting. Check all nailing blocks, plugs, and strips necessary for the attachment of trim, finish, and similar work prior to concreting.

3.08 BEVELED EDGES (CHAMFER)

- A. Form 3/4-inch beveled edges on exposed concrete edges and corners, beam soffit corners, and where indicated on the drawings. Reentrant corners in concrete members shall not have fillets, unless otherwise shown in the drawings. The top edges of slabs, walkways, beams, and walls may be beveled with an edging trowel in lieu of using chamfer strips.

3.09 CONSTRUCTION JOINTS

- A. Layout of construction joints shall be as shown in the drawings and according to the following guidelines:
 - 1. Provide horizontal construction joints at top of foundation members and slabs-on-grade and at the soffit of supported slabs and beams.
 - 2. Space the construction joints at a maximum horizontal distance of 25 feet and a maximum vertical distance of 16 feet.
 - 3. Space the corner vertical construction joints between 4 and 8 feet from the corner of walls or wall intersections.
 - 4. Space horizontal construction joints at least 8 inches below bottom of slabs.
- B. Place expansion joint fillers every 30 feet in straight runs of walks, at right-angle turns, and wherever concrete walks butt into vertical surfaces.
- C. For control joints of nonstructural slabs, provide partial depth plastic strips set flush with finished surface or 1/8-inch-wide joints cut with a diamond saw. Use control joints one-quarter to one-third the depth of the slab unless otherwise indicated.
- D. When it is necessary to make a joint because of an emergency, furnish and place reinforcing dowels across the joint. Embed dowels 48 bar diameters each side of the joint. Size and number of dowels shall match reinforcing in the member.
- E. After the pour has been completed to the construction joint and the concrete has hardened, thoroughly clean the entire surface of the joint of surface laitance, loose or defective concrete, and foreign material, and expose clean aggregate by sandblasting the surface of construction joints before placing the new concrete. Cover horizontal construction joints with mortar. Spread uniformly and work thoroughly into all irregularities of the surface. The water-cement ratio of the mortar in place shall not exceed that of the concrete to be placed, and the consistency of the mortar shall be suitable for placing and working.
- F. In case of emergency, place additional construction joints. (An interval of 45 minutes constitute cause for an emergency construction joint).

3.10 EXPANSION JOINTS

Provide expansion joints with continuous edge reservoirs, which shall be filled with a joint sealant. Leave the material used for forming the reservoirs in place until immediately before the grooves are cleaned and filled with joint sealant. After removing edge forms from the reservoir, remove grout, loose concrete, and fins; then sandblast the slots. Allow the reservoirs to become thoroughly dry; then blow out the reservoirs and immediately prime and fill with the expansion joint sealant and backup materials. The primer used shall be supplied by the same manufacturer supplying the joint sealant.

3.11 TIME BETWEEN POURS

- A. At least two hours shall elapse after depositing concrete in the columns or walls before depositing in beams, girders, or slabs supported thereon. Place beams, girders, brackets, column capitals, and haunches monolithically as part of the floor or roof system, unless otherwise indicated on the drawings.

3.12 PLACING REINFORCEMENT

- A. Place reinforcing steel in accordance with the current edition of Recommended Practice for Placing Reinforcing Bars, published by the Concrete Reinforcing Steel Institute.
- B. Place reinforcing in accordance with the following, unless otherwise indicated:
 - 1. Reinforcement indicated on the drawings is continuous through the structure to the farthest extent possible. Terminate bars 2 inches clear from faces of concrete.
 - 2. Splices may be used to provide continuity due to bar length limitations. Minimum length of bars spliced for this reason is 30 feet. Splicing of reinforcement which is detailed to be continuous on the drawings is not permitted.
- C. Reinforcing steel, before being positioned and just prior to placing concrete, shall be free from loose mill and rust scale from any coatings that may destroy or reduce the bond. Clean reinforcing steel by sandblasting or wire brushing and remove mortar, oil, or dirt to remove materials that may reduce the bond.
- D. Do not straighten or bend reinforcing steel in the field. Do not use reinforcing with bends not shown in the drawings.
- E. Position reinforcing steel in accordance with the drawings and secure by using annealed wire ties or clips at intersections and support by concrete or metal supports, spacers, or metal hangers. Do not place metal clips or supports in contact with the forms. Bend tie wires away from the forms to provide the specified concrete coverage. Bars additional to those shown on the drawings, which may be found necessary or desirable by the Contractor for the purpose of securing reinforcement in position, shall be provided by the Contractor at his own expense.
- F. Place reinforcement a minimum of 2 inches clear of any metal pipe or fittings.
- G. Secure reinforcing dowels in place prior to placing concrete. Do not press dowels into the concrete after the concrete has been placed.
- H. Roll wire mesh used for reinforcement flat before placing concrete. Support and tie wire mesh to prevent movement during concrete placement.
- I. Position dowels for masonry walls to occur at reinforced block cells.

3.13 SITE MIXED CONCRETE

- A. Conform to ACI 304.

3.14 READY MIXED CONCRETE

- A. Conform to ASTM C94.

3.15 PLACING CONCRETE

- A. Conform to ACI 304.

3.16 PUMPING CONCRETE

- A. Conform to ACI 304.2R-91.

3.17 WEATHER REQUIREMENTS

- A. Conform to ACI 305 for placing during hot weather.
- B. Conform to ACI 306 for placing during cold weather.

3.18 BONDING TO OLD CONCRETE

- A. Coat the contact surfaces with epoxy bonding compound. The method of preparation and application of the bonding compound shall conform to the manufacturer's printed instructions and recommendations for specific application for this project.

3.19 GROUTING MACHINERY FOUNDATIONS

- A. Block out the original concrete or finish off a sufficient distance below the bottom of the machinery base to provide for the thickness of grout shown on the drawings. After the machinery has been set in position and wedged to the proper elevation by steel wedges, fill the space between the bottom of the machinery base and the original pour of concrete with a pourable non-shrink grout. Grout and grouting procedure shall be in accordance with API 686, Chapter 4, paragraphs 3.6 and 3.7, and Chapter 5.

3.20 BACKFILL AGAINST WALLS

- A. Do not place backfill against walls until the concrete has obtained a compressive strength equal to the specified 28-day compressive strength. Where backfill is to be placed on both sides of the wall, place the backfill uniformly on both sides.
- B. Do not backfill the walls of structures that are laterally restrained or supported by suspended slabs or slabs on grade until the slab is poured and the concrete has reached the specified compressive strength.

3.21 CONCRETE FINISHES

A. Complete concrete surfaces in accordance with the following schedule:

Finish Designation	Area Applied
F-1	Beams, columns, and exterior walls not exposed to view.
F-4	Exterior and interior surfaces to be coated.
S-1	Slabs and floors to be covered with concrete or grout.
S-4	Slabs and floors of structures or buildings exposed to view.
S-5	Slabs and floors at slopes greater than 10% and stairs.
E-1	Exposed edges. EXCEPTION: edges normally covered with earth.
E-2	Top of walls, beams, and similar unformed surfaces.

B. The following are descriptions of the finish designations:

1. Finish F-1: Repair defective concrete, fill depressions deeper than 1/2 inch, and fill tie holes.
2. Finish F-3: In addition to Finish F-1, remove fins, fill depressions 1/4 inch or deeper, fill depressions and airholes with mortar. Dampen surfaces and then spread a slurry consisting of one part cement and one and one-half parts sand by damp loose volume, over the surface with clean burlap pads or sponge rubber floats. Remove any surplus by scraping and then rubbing with clean burlap.
3. Finish F-4: Repair defective concrete, remove fins, fill depressions 1/16 inch or deeper, fill tie holes, remove mortar spatter, and remove bulges higher than 1/16 inch.
4. Finish S-1: Screed to grade without special finish.
5. Finish S-4: Steel trowel finish without local depressions or high points and apply a light hair broom finish. Do not use stiff bristle brooms or brushes. Leave hair broom lines parallel to the direction of slab drainage.
6. Finish S-5: Steel trowel finish without local depressions or high points. Apply a stiff bristle broom finish. Leave broom lines parallel to the direction of slope drainage.
7. Finish E-1: Provide chamfer or beveled edges.
8. Finish E-2: Strike smooth and float to an F-3 or F-4 finish.

3.22 CURING CONCRETE

- A. Conform to ACI 308.
- B. Water cure with burlap mats unless optional curing methods are permitted.
- C. It is the responsibility of the Contractor to select the appropriate curing method in response to climatical and/or site conditions occurring at the time of concrete placement. Take appropriate measures as described in ACI 305 and 306 for protecting and curing concrete during hot and cold weather.

3.23 REPAIR OF DEFECTS

- A. Do not repair defects until concrete has been reviewed by the Owner or Owner's Representative.
- B. Surface Defects: Repair surface defects that are smaller than 1 foot across in any direction and are less than 1/2 inch in depth.
 - 1. Repair by removing the honeycombed and other defective concrete down to sound concrete, make the edges perpendicular to the surface and at least 3/8 inch deep, thoroughly dampen the surface, work into the surface a bonding grout (one part cement to one-part fine sand), fill the hole with mortar, match the finish on the adjacent concrete, and cure as specified.
- C. Severe Defects: Repair severe defects that are larger than surface defects but do not appear to affect the structural integrity of the structure.
 - 1. Repair by removing the honeycombed and other defective concrete down to sound concrete, make the edges of the hole perpendicular to the surface, sandblast the surface, coat the sandblasted surface with epoxy bonding compound, place no shrink grout, match the finish on the adjacent concrete, and cure as specified.
- D. Major Defects: If the defects are serious or affect the structural integrity of the structure or if patching does not satisfactorily restore the quality and appearance to the surface, the Engineer may require the concrete to be removed and replaced, complete, in accordance with the provisions of this section.

3.24 REPAIR OF CRACK

- A. Repair cracks in concrete structures that are wider than 1/10-inch in width by cutting out a square edged and uniformly aligned joint 3/8 inch wide by 3/4-inch deep, preparing exposed surfaces of the joint, priming the joint, and applying polyurethane joint sealant.
- B. If the cracks are serious or affect the structural integrity or function of the element, the Owner's Representative may require the concrete to be removed and replaced, complete, in accordance with the provisions of this section.

3.25 ALUMINUM SURFACES IN CONTACT WITH CONCRETE

- A. Coat aluminum surfaces in contact with concrete per Section 09900, System No 51.

3.26 CONCRETE TESTS

- A. Concrete quality testing may be performed on the concrete by the Owner as follows:

1. Frequency of Sampling: Cast minimum four concrete test cylinders from each 50 cubic yards, or fraction thereof, of each class of concrete placed in any one day. Sampling and curing of cylinders shall conform to ASTM C 31.
2. Strength Testing: Test cylinders in accordance with ASTM C 39. Test one cylinder at 7 days for information; test two cylinders at 28 days for acceptance; and hold one cylinder for verification. Strength acceptance will be based on the average of the strengths of the two cylinders tested at 28 days. If one cylinder of a 28-day test manifests evidence of improper sampling, molding, or testing, other than low strength, discard it and use the fourth cylinder for the test result. Determine concrete slump by ASTM C 143 with each strength test sampling and as required to establish consistency.
3. Determine air content of the concrete using ASTM C 143 to verify the percentage of air in the concrete immediately prior to depositing in forms.
4. The average value of concrete strength tests shall be equal to or greater than the specified 28-day strength. No test shall be less than 90% of the specified 28-day strength.
5. If the 28-day strength tests fail to meet the specified minimum compressive strength, the concrete will be assumed to be defective and one set of three cores from each area may be taken as selected by the Owner and in accordance with ASTM C 42. If the average compressive strength of the set of three concrete cores fails to equal 90% of the specified minimum compressive strength or if any single core is less than 75% of the minimum compressive strength, the concrete will be considered defective. The Owner may require additional coring, nondestructive load testing, or repair of defective concrete. Costs of coring, testing of cores, load testing, and required repairing pertaining thereto shall be paid by the Contractor at no extra cost to the Owner.

- B. To facilitate concrete sampling and testing, the Contractor shall:

1. Furnish labor to assist the Owner in obtaining and handling samples at the project site.
2. Advise the Owner 24 hours in advance of concrete placing operations to allow for scheduling and completion of quality testing.

3. Provide and maintain facilities for safe storage and proper curing of concrete test specimens on the project site, as required by ASTM C31.

END OF SECTION

DRAFT

SECTION 09811 FUSION-BONDED EPOXY LININGS AND COATINGS

PART 1 - GENERAL

1.01 DESCRIPTION

- A. This section includes materials, application, and testing of one part, fusion bonded, heat cured, thermosetting, 100% solids epoxy linings and coatings on steel, cast iron, and ductile-iron equipment, such as valves, flexible pipe couplings, and ductile-iron pipe.
- B. Related Work Specified Elsewhere:
 - 1. Painting and Coating: 09900
 - 2. Ductile-Iron Pipe: 15056
 - 3. Flexible Pipe Couplings: 15122

1.02 SUBMITTALS

- A. Submit shop drawings in accordance with the General Conditions.
- B. Submit manufacturer's catalog literature and product data sheets, describing the physical and chemical properties of the epoxy coating. Describe application and curing procedure.
- C. Submit coating application test records for measuring coating thickness and holiday detection for each item or pipe section and fitting. Describe repair procedures used.

PART 2 - MATERIALS

2.01 PIPING AND EQUIPMENT SURFACES

- A. The Contractor shall require the equipment suppliers to provide equipment that is free of salts, oil, and grease to the coating applicator.
- B. The Contractor shall require pipe suppliers to provide bare pipe that is free of salts, oil, and grease to the coating applicator.

2.02 SHOP-APPLIED EPOXY LINING AND COATING

- A. Lining and coating shall be 100% solids, thermosetting, fusion-bonded, dry powder epoxy resin: Scotchkote 134 or 206N; Sherwin Williams "Pipeclad 2000"; or equal. Epoxy lining and coating shall meet or exceed the following requirements:

Hardness (minimum)	Barcol 17 (ASTM D2583) Rockwell 50 ("M" scale)
Abrasion resistance (maximum value)	1,000 cycles: 0.05 gram removed
	5,000 cycles: 0.115 gram removed
	ASTM D1044, Tabor CS 17 wheel, 1,000-gram weight
Adhesion (minimum)	3,000 psi (Elcometer)
Tensile strength	7,300 psi (ASTM D2370)
Penetration	0 mil (ASTM G17)
Adhesion overlap shear, 1/8-inch steel panel, 0.010 glue line	4,300 psi, ASTM D1002
Impact (minimum value)	100 inch-pounds (Gardner 5/8-inch diameter tup)

2.03 FIELD-APPLIED EPOXY COATING FOR PATCHING

- A. Use a minimum 80% solids liquid epoxy resin, such as Scotchkote 306 or 323.

2.04 PAINTING AND COATING OF GROOVED-END AND FLEXIBLE PIPE COUPLINGS

- A. Line and coat couplings the same as the pipe. Color shall match the color of the pipe fusion epoxy coating.

PART 3 - EXECUTION

3.01 SHOP APPLICATION OF FUSION-BONDED EPOXY LINING AND COATING

- A. Grind surface irregularities, welds, and weld spatter smooth before applying the epoxy. The allowable grind area shall not exceed 0.25 square foot per location, and the maximum total grind area shall not exceed 1 square feet per item or piece of equipment. Do not use any item, pipe, or piece of equipment in which these requirements cannot be met.
- B. Remove surface imperfections, such as slivers, scales, buns, weld spatter, and gouges. Grind outside sharp corners, such as the outside edges of flanges, to a minimum radius of 1/4 inch.
- C. Uniformly preheat the pipe, item, or piece of equipment prior to blast cleaning to remove moisture from the surface. The preheat shall be sufficient to ensure that the surface temperature is at least 5°F above the dew point temperature during blast cleaning and inspection.
- D. Sandblast surfaces per SSPC SP-5. Protect beveled pipe ends from the abrasive blast cleaning.

- E. Apply a phosphoric acid wash to the pipe, item, or piece of equipment after sandblasting. The average temperature, measured in three different locations, shall be 80°F to 130°F during the acid wash procedure. The acid wash shall be a 5% by weight phosphoric acid solution. The duration in which the acid is in contact with the surface shall be determined by using the average temperature as tabulated below:

Surface Temperature (°F)	Contact Time (seconds)
80	52
85	45
90	36
95	33
100	28
105	24
110	21
130	10

- F. After the acid wash has been completed, remove the acid with demineralized water having a maximum conductivity of 5 micromhos/cm at a minimum nozzle pressure of 2,500 psi.
- G. Apply lining and coating by the electrostatic spray or fluidized bed process. Minimum thickness of lining or coating shall be 15 mils. Heat and cure per the epoxy manufacturer's recommendations. The heat source shall not leave a residue or contaminant on the metal surface. Do not allow oxidation of surfaces to occur prior to coating. Do not permit surfaces to flash rust before coating.
- H. Additional Requirements
1. Apply lining and coating per AWWA C213 except as modified herein.
 2. Grind 0.020 inch (minimum) off the weld caps on the pipe weld seams before beginning the surface preparation and heating of the pipe.

3.02 QUALITY OF LINING AND COATING APPLICATIONS

- A. The cured lining or coating shall be smooth and glossy, with no graininess or roughness. The lining or coating shall have no blisters, cracks, bubbles, under-film voids, mechanical damage, discontinuities, or holidays.

3.03 FACTORY TESTING OF COATING OF PIPE

- A. Test linings and coatings with a low-voltage wet sponge holiday detector. Test pipe linings and coatings per AWWA C213, Section 5.3.3. If the number of holidays or pinholes is fewer than one per 20 square feet of coating surface, repair the holidays and pinholes by applying the coating manufacturer's recommended patching compound to

each holiday or pinhole and retest. If the number of pinholes and holidays exceeds one per 20 square feet of coating surface, remove the entire lining or coating and recoat the item or pipe.

- B. Measure the coating thickness at three locations on each item or piece of equipment or pipe section using a coating thickness gauge calibrated at least once per eight-hour shift. Record each measured thickness value. Where individual measured thickness values are less than the specified minimum thickness, measure the coating thickness at three additional points around the defective area. The average of these measurements shall exceed the specified minimum thickness value, and no individual thickness value shall be more than 2 mils below or 3 mils above the specified minimum value. If a section of the pipe, item, or piece of equipment does not meet these criteria, remove the entire lining or coating and recoat the entire item or piece of equipment.
- C. Additional requirements:
 - 1. Check for coating defects on the weld seam centerlines. There shall be no porous blisters, craters, or pimples lying along the peak of the weld crown.

3.04 FIELD REPAIRS

- A. Patch scratches and damaged areas incurred while installing fusion bonded epoxy coated items with a two-component, 80% solids (minimum), liquid epoxy resin. Wire brush or sandblast the damaged areas per SSPC SP-10. Lightly abrade or sandblast the coating or lining on the sides of the damaged area before applying the liquid epoxy coating. Apply a two-part epoxy coating to defective linings and coatings to areas smaller than 20 square inches. Patched areas shall overlap the parent or base coating a minimum of 0.5 inch. If a defective area exceeds 20 square inches, remove the entire lining and coating and recoat the entire item or piece of equipment. Apply the liquid epoxy coating to a minimum dry-film thickness of 15 mils.

END OF SECTION

SECTION 09900 PAINTING AND COATING

PART 1 - GENERAL

1.01 DESCRIPTION

- A. This section includes materials and application of painting and coating systems for the following surfaces:

1. Submerged metal
2. Exposed metal
3. Buried metal
4. Metal in contact with concrete
5. Fusion-bonded epoxy coated steel

It does not include coating steel water tanks and reservoirs.

- B. Related Work Specified Elsewhere:

1. General Concrete Construction: 03000
2. Fusion-Bonded Epoxy Linings and Coatings: 09811

1.02 SUBMITTALS

- A. Submit shop drawings in accordance with the General Conditions.

- B. Submit manufacturer's data sheets showing the following information:

1. Percent solids by volume.
2. Minimum and maximum recommended dry-film thickness per coat for prime, intermediate, and finish coats.
3. Recommended surface preparation.
4. Recommended thinness.
5. Statement verifying that the specified prime coat is recommended by the manufacturer for use with the specified intermediate and finish coats.
6. Application instructions including recommended equipment and temperature limitations.

- 7. Curing requirements and instructions.
- C. Submit color swatches.
- D. Submit certificate identifying the type and gradation of abrasives used for surface preparation.

PART 2 - MATERIALS

2.01 PAINTING AND COATING SYSTEMS

- A. The following index lists the various painting and coating systems by service and generic type:

PAINT COATINGS SYSTEM INDEX

No.	Title	Generic Coating
Submerged Metal Coating Systems		
7.	Submerged Metal, Potable or Non-potable Water	Epoxy
12.	Exposed Metal, Corrosive Environment	Epoxy (three-coat system)
15.	Exposed Metal, Atmospheric Weathering or Water Condensation Environment	Acrylic
21.	Buried Metal	Fast setting mortar, Speedcrete or equal
24.	Buried Metal	Corrosion-resisting grease
51.	Aluminum Insulation from Concrete and Carbon Steel	Bituminous
65.	Epoxy-Coated Surfaces, Color Coding	Alkyd

These systems are specified in detail in the following paragraphs. For each coating, the required surface preparation, prime coat, intermediate coat (if required), topcoat and coating thicknesses are described. Mil thicknesses shown are minimum dry-film thicknesses

2.02 SUBMERGED METAL COATING SYSTEMS

- A. System No. 7--Submerged Metal, Potable or Non potable Water:

Type: Epoxy

Service Conditions: For use with structures, valves, piping, or equipment immersed in potable or non-potable water.

Surface Preparation: SSPC SP-10.

Coating System: Apply the manufacturer's recommended number of coats to attain the specified minimum coating thickness. Products: Tnemec Series 100, Devoe Bar-Rust 233H, Ameron 395FD, . Keysite 740, Scotchkote 323, or equal; 20 mils total. Color of topcoat: white.

2.03 EXPOSED METAL COATING SYSTEMS

A. System No. 12 —Exposed Metal, Corrosive Environment:

Type: Gloss polyamide cured epoxy having a minimum volume solids content of 50% with epoxy prime coat.

Service Conditions: For use with metal structures or pipes subjected to water condensation and chemical fumes, such as hydrogen sulfide.

Surface Preparation: SSPC SP-10.

Prime Coat: Polyamide-cured epoxy primer having minimum volume solids content of 50% (ASTM D 2697) Products: Carboline 890 or 893, Devoe Devran 224HS, Tnemec N69, International Interguard 750HS, PPG Amercoat 385, Sherwin-Williams Macropoxy 646 B58-600, PPG PITT-GUARD® Direct-to-Rust Epoxy Mastic Coating 97-145 series, or equal. Apply to a minimum dry-film thickness of 4 mils.

Finish Coat: Two coats of Carboline 890, two coats of Devoe Devran 224HS, two coats Tnemec N69, two coats of International Interguard 760HS, two coats of PPG Amercoat 385, two coats of Sherwin-Williams Macropoxy 646 B58-600, two coats of PPG Tile-8® Gloss Epoxy 95-6749, or equal. Apply to a thickness of 4 mils per coat.

B. System No. 15--Exposed Metal, Atmospheric Weathering Environment:

Type: One component acrylic enamel having a minimum volume solids content of 35% with an acrylic primer.

Service Conditions: use on exterior metal and piping subject to sunlight and weathering
Surface Preparation: SSPC SP-6.

Prime Coat: Sherwin-Williams Pro-Cryl Universal Primer, Devoe Devflex 4020DTM water-borne primer, Carboline 3358, Tnemec Series 18, or equal, applied to minimum dry film thickness of three mils.

Finish Coat: Two or more coats of Sherwin-Williams Sher-Cryl B66–300, Devoe Devflex 659, Carbocrylic 3359 or 3359DTM, Tnemec Series 28 or 29, or equal. Apply sufficient coats to provide a total minimum dry-film thickness of 8 mils. Thickness of any individual coat shall not exceed 4 mils.

2.04 BURIED METAL COATING SYSTEMS

A. System No. 21--Buried Metal:

Type: High solids epoxy or phenolic epoxy having a minimum volume solids of 80% (ASTM D 2697).

Service Conditions: Buried metal, such as valves, flanges, bolts, nuts, structural steel, and fittings.

Surface Preparation: SSPC SP-10.

Coating System: Apply three or more coats of Ameron 400, Tnemec 104 HS or 80, Devco Bar-Rust 233H, Carbolite 890LT, Sherwin-Williams Tank Clad HS B62-80 series or equal; 30 mils total.

B. System No. 24--Buried Metal:

Type: Corrosion-resisting grease.

Service Conditions: Buried metal, such as bolts, bolt threads, tie rods, and nuts.

Surface Preparation: SSPC SP-3 or SP-6.

Coating: NO-OX-ID GG-2 as manufactured by Sanchem, Inc. Apply to a minimum thickness of 1/4 inch.

2.05 COATING SYSTEMS FOR NON-FERROUS METALS

A. System No. 51--Aluminum and Concrete Insulation:

Type: Bituminous paint having a minimum volume solids of 68% coal-tar pitch based.

Service Conditions: Coat areas of aluminum grating, stairs, structural members or aluminum fabrications, in contact with concrete with this system.

Surface Preparation: Solvent or steam cleaning per SSPC SP-1; do not use alkali cleaning. Then dust blast.

Prime Coat: Apply synthetic resin or epoxy primer to metal surface before finish coats. Products: International Intervinix VTA528/529, or equal. No primer required for Carbolite or Tnemec.

Finish Coat: Carbolite Bitumastic 50, Tnemec 46-465, International Intertuf 100, or equal. Apply two coats to a minimum dry-film thickness of 12 mils each.

2.06 COATING SYSTEMS FOR FUSION EPOXY-COATED STEEL SURFACES

A. System No. 65—Epoxy-Coated Surfaces, Color Coding:

Type: Gloss alkyd enamel having a minimum volume solids content of 50%.

Application: Color coding of pipe or steel surfaces already coated with fusion bonded epoxy.

Surface Preparation: SSPC SP-1. Then sweep blast the epoxy surface per SP-7 to provide a 2- to 3-mil profile in the bonded epoxy substrate.

Prime Coat: None.

Finish Coat: Two coats of Carboline Carbocoat 139, two coats of Tnemec Series 2H, two coats of International Interlac 820, two coats of PPG Amercoat 5450, two coats of Devco 4348, Sherwin-Williams Industrial Enamel B54Z series, PPG MetalMax Int/Ext Gloss Alkyd 7-914 series, or equal. Apply to a thickness of 1.5 mils per coat.

2.07 ABRASIVES FOR SURFACE PREPARATION

- A. Abrasives used for preparation of iron and steel surfaces shall be one of the following:
 1. 16 to 30 or 16 to 40 mesh silica-free sand or mineral grit.
 2. 20 to 40 mesh garnet.
 3. Crushed iron slag, 100% retained on No. 80 mesh.
 4. SAE Grade G-40 or G-50 iron or steel grit.
- B. In the above gradations, 100% of the material shall pass through the first stated sieve size and 100% shall be retained on the second stated sieve size.

PART 3 - EXECUTION

3.01 WEATHER CONDITIONS

- A. Do not paint in the rain, wind, snow, mist, and fog or when steel or metal surface temperatures are less than 5°F above the dew point.
- B. Do not apply paint when the relative humidity is above 85%.
- C. Do not paint when temperature of metal to be painted is above 110°F.
- D. Do not apply alkyd, inorganic zinc, silicone aluminum, or silicone acrylic paints if air or surface temperature is below 40°F or expected to be below 40°F within 24 hours.
- E. Do not apply epoxy, acrylic latex, and polyurethane paints on an exterior or interior surface if air or surface temperature is below 60°F or expected to drop below 60°F in 24 hours.

3.02 SURFACE PENETRATION

- A. Do not sandblast or prepare more surface area in one day than can be coated in one day; prepare surfaces and apply coatings the same day. Remove all sharp edges, burrs, and weld spatter. Do not sandblast epoxy- or enamel-coated pipe that has already been factory coated, except to repair scratched or damaged coatings.
- B. For carbon steel, do not touch the surface between the time of abrasive blasting and the time the coating is applied. Apply coatings within two hours of blasting or before any rust bloom forms.
- C. Surface preparation shall conform with the SSPC specifications as follows:

Solvent Cleaning	SP-1
Hand Tool Cleaning	SP-2
Power Tool Cleaning	SP-3
White Metal Blast Cleaning	SP-5
Commercial Blast Cleaning	SP-6
Brush-Off Blast Cleaning	SP-7
Pickling	SP-8
Near-White Blast Cleaning	SP-10
Power Tool Cleaning to Bare Metal	SP-11
Surface Preparation and Cleaning of Steel and Other Hard Materials by High- and Ultrahigh-Pressure Water Jetting Prior to Recoating	SP-12
Surface Preparation of Concrete	SP-13

- D. Wherever the words "solvent cleaning," "hand tool cleaning," "wire brushing," or "blast cleaning" or similar words are used in these specifications or in paint manufacturer's specifications, they shall be understood to refer to the applicable SSPC (Steel Structure Painting Council, Surface Preparation Specifications, ANSI A159 1) specifications listed above.
- E. Dust blasting is defined as cleaning the surface through the use of very fine abrasives, such as siliceous or mineral abrasives, 80 to 100 mesh. Apply a fine etch to the metal surface to clean the surface of any contamination oxide.
- F. Remove oil and grease from metal surfaces in accordance with SSPC SP-1 Use clean cloths and cleaning solvents and wipe dry with clean cloths. Do not leave a film or greasy residue on the cleaned surfaces before sandblasting.
- G. Remove weld spatter and weld slag from metal surface and grind smoothly rough welds, beads, peaked corners, and sharp edges including erection lugs in accordance with SSPC

SP-2 and SSPC SP-3. Grind 0.020 inch (minimum) off the weld caps on pipe weld seams. Grind outside sharp corners, such as the outside edges of flanges, to a minimum radius of 1/4 inch.

3.03 ABRASIVE BLAST CLEANING

- A. Use dry abrasive blast cleaning for metal surfaces. Do not use abrasives in automatic equipment that have become contaminated. When shop or field blast cleaning with handheld nozzles, do not recycle or reuse blast particles.
- B. After blast cleaning and prior to application of coating, dry clean surfaces to be coated by dusting, sweeping, and vacuuming to remove residue from blasting. Apply the specified primer or touch-up coating within the period of an eight-hour working day. Do not apply coating over damp or moist surfaces. Reclean prior to application of primer or touch-up coating any blast cleaned surface not coated within said eight-hour period.
- C. Keep the area of the work in a clean condition and do not permit blasting particles to accumulate and constitute a nuisance or hazard.
- D. During sandblast cleaning, prevent damage to adjacent coatings. Schedule blast cleaning and coating such that dust, dirt, blast particles, old coatings, rust, mill scale, etc., will not damage or fall upon wet or newly coated surfaces.

3.04 PROCEDURE FOR ITEMS HAVING SHOP-APPLIED PRIME COATS

- A. After application of primer to surfaces, allow coating to cure for a minimum of two hours before handling to minimize damage.
- B. When loading for shipment to the project site, use spacers and other protective devices to separate items to prevent damaging the shop-primed surfaces during transit and unloading. If wood spacers are used, remove wood splinters and particles from the shop-primed surfaces after separation. Use padded chains or ribbon binders to secure the loaded items and minimize damage to the shop-primed surfaces.
- C. Cover shop-primed items 100% with protective coverings or tarpaulins to prevent deposition of road salts, fuel residue, and other contaminants in transit.
- D. Handle shop-primed items with care during unloading, installation, and erection operations to minimize damage. Do not place or store shop-primed items on the ground or on top of other work unless ground or work is covered with a protective covering or tarpaulin. Place shop-primed items above the ground upon platforms, skids, or other supports.

3.05 FIELD TOUCH-UP OF SHOP-APPLIED PRIME COATS

- A. Remove oil and grease surface contaminants on metal surfaces in accordance with SSPC SP-1. Use clean sags wetted with a degreasing solution, rinse with clean water, and wipe dry.

- B. Remove dust, dirt, salts, moisture, chalking primers, or other surface contaminants that will affect the adhesion or durability of the coating system. Use a high-pressure water blaster or scrub surfaces with a broom or bush wetted with a solution of trisodium phosphate, detergent, and water. Rinse scrubbed surfaces with clean water.
- C. Remove loose or peeling primer and other surface contaminants not easily removed by the previous cleaning methods in accordance with SSPC SP-7. Take care that remaining primers are not damaged by the blast cleaning operation. Remaining primers shall be firmly bonded to the steel surfaces with blast cleaned edges feathered.
- D. Remove rust, scaling, or primer damaged by welding or during shipment, storage, and erection in accordance with SSPC SP-10. Take care that remaining primers are not damaged by the blast cleaning operation. Areas smaller than 1 square inch and that show no evidence of rust may be prepared per SSPC SP-11 to a bright metal finish. Remaining primers shall be firmly bonded to the steel surfaces with cleaned edges feathered.
- E. Use repair procedures on damaged primer which protects adjacent primer. Blast cleaning may require the use of lower air pressure, smaller nozzles, and abrasive particle sizes, short blast nozzle distance from surface, shielding, and/or masking.
- F. After abrasive blast cleaning of damaged and deflective areas, remove dust, blast particles, and other debris by dusting, sweeping, and vacuuming; then apply the specified touch-up coating.
- G. Surfaces that are shop primed shall receive a field touch-up of the same primer used in the original prime coat.

3.06 PAINTING SYSTEMS

- A. All materials of a specified painting system, including primer, intermediate, and finish coats, shall be produced by the same manufacturer. Thinness, cleaners, driers, and other additives shall be as recommended by the paint manufacturer for the particular coating system.
- B. Deliver paints to the jobsite in the original, unopened containers.

3.07 PAINT STORAGE AND MIXING

- A. Store and mix materials only in areas designated for that purpose by the Owner's Representative. The area shall be well-ventilated, with precautionary measures taken to prevent fire hazards. Post "No Smoking" signs. Storage and mixing areas shall be clean and free of rags, waste, and scrapings. Tightly close containers after each use. Store paint at an ambient temperature from 50°F to 100°F.
- B. Prepare multiple-component coatings using all the contents of the container for each component as packaged by the paint manufacturer. Do not use partial batches. Do not use multiple-component coatings that have been mixed beyond their pot life. Provide small quantity kits for touch-up painting and for painting other small areas. Mix only the

components specified and furnished by the paint manufacturer. Do not intermix additional components for reasons of color or otherwise, even within the same generic type of coating.

3.08 PROCEDURES FOR THE APPLICATION OF COATINGS

- A. Conform to the requirements of SSPC PA-1. Follow the recommendations of the coating manufacturer including the selection of spray equipment, brushes, rollers, cleaners, thinness, mixing, drying time, temperature and humidity of application, and safety precautions.
- B. Stir, strain, and keep coating materials at a uniform consistency during application. Apply each coating evenly, free of brush marks, sags, runs, and other evidence of poor workmanship. Use a different shade or tint on succeeding coating applications to indicate coverage where possible. Finished surfaces shall be free from defects or blemishes.
- C. Do not use thinners or additives unless recommended by the coating manufacturer. If thinning is allowed, do not exceed the maximum allowable amount of thinner per gallon of coating material. Stir coating materials at all times when adding thinner. Do not flood the coating material surface with thinner prior to mixing. Do not reduce coating materials more than is absolutely necessary to obtain the proper application characteristics and to obtain the specified dry-film thicknesses.
- D. Remove dust, blast particles, and other debris from blast cleaned surfaces by dusting, sweeping, and vacuuming. Allow ventilator fans to clean airborne dust to provide good visibility of working area prior to coating applications. Remove dust from coated surfaces by dusting, sweeping, and vacuuming prior to applying succeeding coats.
- E. Apply coating systems to the specified minimum dry-film thicknesses as determined per SSPC PA-2.
- F. Apply primer immediately after blast cleaning and before any surface rusting occurs, or any dust, dirt, or any foreign matter has accumulated. Reclean surfaces by blast cleaning that have surface colored or become moist prior to coating application.
- G. Apply a brush coat of primer on welds, sharp edges, nuts, bolts, and irregular surfaces prior to the application of the primer and finish coat. The brush coat shall be done prior to and in conjunction with the spray coat application. Apply the spray coat over the brush coat.
- H. Applied coating systems shall be cured at 75°F or higher for 48 hours. If temperature is lower than 75°F, curing time shall be in accordance with printed recommendations of the manufacturer, unless otherwise allowed by the Owner's Representative.
- I. Assembled parts shall be disassembled sufficiently before painting or coating to ensure complete coverage by the required coating.

3.09 SURFACES NOT TO BE COATED

- A. Do not paint the following surfaces unless otherwise noted in the drawings or in other specification sections Protect during the painting of adjacent areas:
1. Mortar-coated pipe and fittings
 2. Copper tubing, zed brass piping, and PVC piping
 3. Nameplates
 4. Grease fittings
 5. Buried pipe, unless specifically required in the piping specifications

3.10 PROTECTION OF SURFACES NOT TO BE PAINTED

- A. Remove, mask, or otherwise protect hardware, lighting fixtures, switch plates, aluminum surfaces, machined surfaces, couplings, shafts, bearings, nameplates on machinery, and other surfaces not intended to be painted. Provide drop cloths to prevent paint materials from falling on or marring adjacent surfaces. Protect working parts of mechanical and electrical equipment from damage during surface preparation and painting process. Mask openings in motors to prevent paint and other materials from entering the motors.

3.11 SURFACES TO BE COATED

- A. The exact coating to be applied in any location is not designated by the descriptive phrases in the coating system titles such as "corrosive environment," "buried metal," or "submerged metal " Coat surfaces with the specific coating systems as described below:
1. Coat aboveground and exposed piping or piping in vaults and structures as described in the various piping specifications.
 2. Coat valves as described in the various valve specifications. Aboveground valves, or valves in vaults and structures, shall match the color of the connecting piping.
 3. Coat aluminum surfaces in contact with concrete per System No. 51.
 4. Coat buried flanges, nuts and bolts, valves, flexible pipe couplings, exposed rebar in thrust blocks, and valve boxes per System No. B-1 or B-2 as specified in the particular specifications for the above items. Coat buried bolt threads, tie bolt threads, and nuts per System No. 24.

3.12 DRY-FILM THICKNESS TESTING

- A. Measure coating thickness specified for metal and concrete surfaces with a magnetic-type dry-film thickness gauge in accordance with SSPC PA-2. Test the finish coat (except zinc primer and galvanizing) for holidays and discontinuities with an electrical holiday detector, low-voltage, wet-sponge type. Provide measuring equipment. Provide detector

as manufactured by Tinker and Razor or K-D Bird Dog. Provide dry-film thickness gauge as manufactured by Mikrotest or Elcometer. Check each coat for the correct dry-film thickness. Do not measure within eight hours after application of the coating.

- B. For metal surfaces, make five separate spot measurements (average of three readings) spaced evenly over each 100 square feet of area (or fraction thereof) to be measured. Make three readings for each spot measurement of either the substrate or the paint. Move the probe 1 to 3 inches for each new gauge reading. Discard any unusually high or low gauge reading that cannot be repeated consistently. Take the average (mean) of the three gauge readings as the spot measurement. The average of five spot measurements for each such 100 square foot area shall not be less than the specified thickness. No single spot measurement in any 100 square foot area shall be less than 80%, nor more than 120%, of the specified thickness. One of three readings which are averaged to produce each spot measurement may underrun by a greater amount as defined by SSPC PA-2.

3.13 REPAIR OF IMPROPERLY COATED SURFACES

- A. If the item has an improper finish color or insufficient film thickness, clean and topcoat the surface with the specified paint material to obtain the specified color and coverage. Sandblast or power-sand visible areas of chipped, peeled, or abraded paint, feathering the edges. Then prime and finish coat in accordance with the specifications. Work shall be free of runs, bridges, shiners, laps, or other imperfections.

END OF SECTION

SECTION 15000 PIPING SCHEDULE & GENERAL PIPING REQUIREMENTS

PART 1 - GENERAL

1.01 DESCRIPTION

- A. This section describes the general requirements for selecting piping materials; selecting the associated bolts, nuts, and gaskets for flanges for the various piping services in the project; and miscellaneous piping items such as flange insulation kits.

1.02 SUBMITTALS

- A. Submit shop drawings in accordance with the General Conditions.
- B. Submit affidavit of compliance with referenced standards (AWWA, ANSI, ASTM, etc).
- C. Submit certified copies of mill test reports for bolts and nuts, including coatings if specified. Provide recertification by domestic testing laboratory for materials originating outside of the United States.
- D. Submit manufacturer's data sheet for gaskets supplied showing dimensions and bolting recommendations.
- E. Submit manufacturer's data sheet for insulating unions, showing recommended installation procedures.

1.03 DEFINITIONS OF BURIED AND EXPOSED PIPING

- A. Buried piping is piping buried in the soil, commencing at the wall or beneath the slab of a structure. Where a coating is specified, provide the coating up to the structure wall. Unless detailed otherwise, coating shall penetrate wall no less than 1 inch. Piping encased in concrete is considered to be buried. Do not coat encased pipe.
- B. Exposed piping is piping in any of the following conditions or locations:
 - 1. Above ground.
 - 2. Inside buildings, vaults, or other structures.
 - 3. In underground concrete trenches or galleries.

PART 2 – MATERIALS

2.01 BOLTS AND NUTS FOR FLANGES FOR DUCTILE IRON PIPING SPECIFICATION SECTION 15056.

- A. Bolts and nuts for flanges located indoors and in vaults and structures shall be stainless steel, ASTM F593.
- B. Bolts and nuts for buried and submerged flanges and flanges located outdoors above ground

shall be Type 316 stainless steel conforming to ASTM A 193, Grade B8M, for bolts and ASTM A 194, Grade 8M, for nuts.

- C. Bolts used in flange insulation kits shall conform to ASTM A 193 (Grade B7). Nuts shall conform to ASTM A 194 (Grade 2H).
 - D. Provide washers for each nut. Washers shall be of the same material as the nuts.
- 2.02 BOLTS AND NUTS FOR FLANGES FOR PVC PIPE (SPECIFICATION SECTION 15064)
- A. Bolts and nuts for flanges located indoors and in vaults and structures shall be stainless steel, ASTM F593.
 - B. Bolts and nuts for buried and submerged flanges and flanges located outdoors above ground shall be Type 316 stainless steel conforming to ASTM A193, Grade B8M for bolts and ASTM A194, Grade 8M for nuts.
 - C. Provide a washer under each nut and under each bolthead. Washers shall be stainless steel.
- 2.03 LUBRICANT FOR STAINLESS-STEEL BOLTS AND NUTS
- A. Lubricant shall be chloride free and shall be RAMCO TG-50, Anti-Seize by RAMCO, Specialty Lubricants Corporation Husky, Lube O'Seal, or equal.
- 2.04 GASKETS FOR FLANGES FOR DUCTILE-IRON PIPING AND FITTINGS IN WATER SERVICE (SPECIFICATION SECTION 15056)
- A. Gaskets shall be full face, 1/8-inch thick, cloth-inserted rubber, John Crane Co. Style 19777 or equal. Gaskets shall be suitable for a water pressure of 200 psi at a temperature of 180 °F. Gaskets shall have “nominal” pipe size inside diameters not the inside diameters of ANSI B16.21.
- 2.05 GASKETS FOR FLANGES FOR PVC PIPING (SPECIFICATION SECTIONS 15064)
- A. Gaskets for flanged joints shall be full faced, 1/8-inch thick, made of EPDM with a hardness of Durometer “A” 85 to 90. When the mating flange has a raised face, provide a flat ring gasket filler between the PVC flange and the adjacent flange.
- 2.06 FLANGE INSULATION KITS
- A. Flange insulation kits shall consist with Specification 16640, Cathodic Protection and Joint Bonding.
- 2.07 WRAPPING FOR PROTECTION OF NUTS AND BOLT THREADS
- A. Nuts and bolts shall be wrapped with a 8-mil polyethylene encasement wrap and coated in accordance with AWWA C105.

PART 3 - EXECUTION

3.01 INSTALLING PIPE SPOOLS IN CONCRETE

- A. Install pipes in walls and slabs before placing concrete. See Sections 03000.

3.02 INSTALLING FLANGED PIPING

- A. Set pipe with the flange bolt holes straddling the pipe horizontal and vertical centerline. Install pipe without springing, forcing, or stressing the pipe or any adjacent connecting valves or equipment.
- B. Clean flanges by wire brushing before installing flanged fittings. Clean flange bolts and nuts by wire brushing, lubricate carbon steel bolts with oil and graphite, and tighten nuts uniformly and progressively. If flanges leak under pressure testing, loosen or remove the nuts and bolts, reset or replace the gasket, reinstall or retighten the bolts and nuts, and retest the joints. Joints shall be watertight.
- C. Install threaded nut and bolt thread protection caps after completing the bolt, nut, and gasket installation. Install on piping.

3.03 INSTALLATION OF STAINLESS-STEEL BOLTS AND NUTS

- A. Prior to assembly, coat threaded portions of stainless-steel bolts and nuts with lubricant.

END OF SECTION

SECTION 15041 DISINFECTION OF PIPING

PART 1 – GENERAL

1.01 DESCRIPTION

- A. This section includes materials and procedures for disinfection of water mains by the continuous feed method. Do not use the tablet method to disinfect pipelines. Disinfect piping in accordance with AWWA C651 as modified below.
- B. Related Work Described Elsewhere
 - 1. Pressure Testing of Piping: 15044.

1.02 JOB CONDITIONS

- A. Discharge of chlorinated water into watercourses or surface waters is regulated by the National Pollutant Discharge Elimination System (NPDES). Apply to cognizant environmental regulation authority and obtain permit, for permission to discharge. Disposal of the chlorinated disinfection water and the flushing water is the Contractor's responsibility.
- B. Use potable water for chlorination.
- C. Submit request for use of water from waterlines of the District 48 hours in advance.

PART 2 - MATERIALS

2.01 Liquid Chlorine

- A. Inject with a solution feed chlorinator and a water booster pump. Use an experienced operator and follow the instructions of the chlorinator manufacturer.

2.02 Calcium Hypochlorite (Dry)

- A. Dissolve in water to a known concentration in a drum and pump into the pipeline at a metered rate.

2.02 Sodium Hypochlorite (Solution)

- A. Further dilute in water to desired concentration and pump into pipeline at a metered rate.

2.03 Chlorine Residual Test Kit

- A. For measuring chlorine concentration, supply and use a medium range, drop count, DPD drop dilution method kit per AWWA C651, Appendix A.1. Maintain kits in good working order available for immediate test or residuals at point of sampling.

PART 3 - EXECUTION

3.01 Continuous Feed Method for Pipelines

- A. Introduce potable water into the pipeline at a constant measured rate. Feed the chlorine solution into the same water at a measured rate. Proportion the two rates so that the chlorine concentration in the pipeline is maintained at a minimum concentration of 50 mg/l. Check the concentration at points downstream during the filling to ascertain that sufficient chlorine is being added.

3.02 Disinfection of Valves and Appurtenances

- A. During the period that the chlorine solution or slug is in the section of pipeline, open and close valves to obtain a chlorine residual at hydrants and other pipeline appurtenances. Swab exposed faces of valves and blind flanges prior to bolting flanges in place with a 1% sodium hypochlorite solution.

3.03 Disinfection of Connections to Existing Pipelines

- A. Disinfect per AWWA C651, Section 4.7. Flush with potable water until discolored water, mud, and debris are eliminated. Swab the interior of pipe and fitting with a 1% sodium hypochlorite solution. After disinfection, flush with potable water again until is free of chlorine odor.

3.04 Confirmation of Residual

- A. After the chlorine solution applied by the continuous feed method has been retained in the pipeline for 24 hours, confirm that a chlorine residual of 25 mg/L minimum exists along the pipeline by sampling at air valves and other points of access.

3.05 Pipeline Flushing

- A. After the confirming the chlorine residual, flush the excess chlorine solution from the pipeline until the chlorine concentration in the water leaving the pipe is within 0.5 mg/L of the replacement water.
- B. Prior to discharge of chlorinated water into any storm drain system, eliminate the chlorine residual using a dechlorinating agent, as described in AWWA C655.

3.06 Bacteriologic Tests

- A. Collect two samples per AWWA C651, Section 5.1, deliver to a certified laboratory within six hours of obtaining the samples, and obtain a bacteriologic quality test to demonstrate the absence of coliform organisms in each separate section of the pipeline after chlorination and refilling. For lines longer than 2 miles, obtain one additional test each mile. At each connection to an existing pipeline, take two additional samples.

3.07 Repetition of Procedure

- A. If the initial chlorination fails to produce required residuals and bacteriological tests, repeat the chlorination and retesting until satisfactory results are obtained.

3.08 Test Facility Removal

- A. After satisfactory disinfection, replace air valves, restore the pipe coating, and complete the pipeline where temporary disinfection or test facilities were installed.

END OF SECTION

SECTION 15044 PRESSURE TESTING OF PIPING

PART 1 - GENERAL

1.01 Description

- A. This section specifies the hydrostatic, and leakage testing of pressure piping for water distribution and transmission mains service connections, fire hydrants and other appurtenances.

1.02 Related Work Specified Elsewhere

- A. Disinfection of Piping: 15041
- B. Manual, Check, and Process Valves: 15100

1.03 Submittals

- B. Submit six copies of the test records to the Owner’s Representative upon completion of the testing.

1.04 Test Pressures

- A. Test pressures shall be based on the following hydraulic gradient lines (HGL):

Zone	Static HGL (feet)	Test HGL (feet)
Wholesale Zone		
560	560	660
736	736	836
788	788	888
Residential Zone		
1	790	890
2	660	760
3	620	720
4	555	655

1.05 Testing Records

- A. Provide records of each piping installation during testing. These records shall include:
 1. Date of test.
 2. Identification of pipeline, or pipeline section, tested or retested.
 3. Identification of pipeline materials.

4. Identification of pipe specification.
5. Test fluid.
6. Test pressure.
7. Remarks: Leaks identified (type and location), types of repairs, or corrections made.
8. Certification by Contractor that the leakage rate measured conformed to the specifications.

PART 2 - MATERIALS

2.01 Manual Air-Release Valves for Buried Piping

- A. Provide temporary manual air-release valves for pipeline test. Construct the pipe outlet in the same manner as for a permanent air valve and after use, seal with a blind flange, pipe cap, or plug and coat the same as the adjacent pipe.

2.02 Testing Fluid

- A. For potable water pipelines, obtain and use only potable water for hydrostatic testing.
- B. Submit request for use of water from waterlines of the District 48 hours in advance.
- C. The Contractor may obtain the water from the District at the District's rate of charges.

2.03 Testing Equipment

- A. Provide pressure gauges, pipes, bulkheads, pumps, and meters to perform the hydrostatic testing.

PART 3 - EXECUTION

3.01 Testing Preparation

- A. Pipes shall be in place and anchored before commencing pressure testing.
- B. For buried pipeline, the pipe may be partially backfilled and the joints left exposed for inspection for an initial leakage test. Perform the final test, however, after completely backfilling and compacting the trench.
- C. Provide any temporary piping needed to carry the test fluid to the piping that is to be tested. After the test has been completed and demonstrated to comply with the specifications, disconnect and remove temporary piping. Do not remove exposed vent and drain valves at

the high and low points in the tested piping; remove any temporary buried valves and cap the associated outlets. Plug taps or connections to the existing piping from which the test fluid was obtained.

- D. Provide temporary drain lines needed to carry testing fluid away from the pipe being tested. Remove such temporary drain lines after completing the pressure testing. Drain the pipes after they have been tested.

3.02 Cleaning

- A. Before conducting hydrostatic tests, flush pipes with water to remove dirt and debris. Maintain a flushing velocity of at least 3 fps for water testing. Flush pipes for time period as given by the formula:

$$T = \frac{2L}{3}$$

in which:

T = flushing time (seconds)

L = pipe length (feet)

3.03 Testing and Disinfection Sequence for Potable Water Piping

- A. Perform required chlorination after hydrostatic testing, except when pipeline being testing is connected to a potable waterline.
- B. Locate and install test bulkheads, valves, connections to existing pipelines, and other appurtenances in a manner to provide an air gap separation between existing potable water pipelines and the pipeline being tested. Disinfect water and pipeline being tested before hydrostatic testing when connected to a potable waterline.

3.04 Length of Test Section for Buried Piping

- A. The maximum length of test section for buried pipe of 12 inches or smaller in diameter is 3500 feet; for buried pipe larger than 12 inches, 1 mile. Provide test bulkheads where the distance between inline valves exceeds these limits.

3.05 Initial Pipeline Filling for Hydrostatic Testing

- A. Maximum rate of filling shall not cause water velocity in pipeline to exceed 1 fps. Filling may be facilitated by removing automatic air valves and releasing air manually.

3.06 Testing New Pipe Which Connects to Existing Pipe

- A. Prior to testing new pipelines that are to be connected to existing pipelines, isolate the new line from the existing line by means of test bulkheads or blind flanges. After successfully

testing the new line, remove test bulkheads or flanges and connect to the existing piping.

3.07 Hydrostatic Testing of Buried Piping

- A. Where any section of the piping contains concrete thrust blocks or encasement, do not perform the pressure test until at least 3 days after placing the concrete. When testing mortar-lined or PVC piping, fill the pipe to be tested with water and allow it to soak for at least 48 hours to absorb water before conducting the pressure test.
- B. Apply and maintain the test pressure by means of a hydraulic force pump.
- C. Maintain the test pressure for the following duration by restoring it whenever it falls an amount of 5 psi:

Pipe Diameter (inches)	Hours
18 and less	4
20 to 27	8

- D. After the test pressure is reached, use a meter to measure the additional water added to maintain the pressure. This amount of water is the loss due to leakage in the piping system. The allowable leakage rate is defined by the formula:

$$L = \frac{HND(P)^{1/2}}{C}$$

in which:

- H = Specified test period (hours)
- L = Allowable leakage (gallons)
- N = Number of rubber-gasketed joints in the pipe tested
- D = Diameter of the pipe (inches)
- P = Specified Temperature (psig)
- C = 7,400

- E. The allowable leakage for buried piping having threaded, brazed, or welded (including solvent welded) joints shall be as follows:

Pipe Size (Inches)	Allowable Leakage for 200 psi Test Pressure (Gallons per four hours per 1,000 feet of pipe)	Allowable Leakage for 250 psi Test Pressure (Gallons per four hours per 1,000 feet of pipe)
4	0.38	0.43
6	0.57	0.64
8	0.76	0.85
10	0.96	1.07
12	1.15	1.28
16	1.53	1.71
18	1.72	1.92
24	2.29	2.56

- F. Repair and retest any pipes showing leakage rates greater than that allowed in the above criteria.

3.08 Repetition of Test

- A. If the actual leakage exceeds the allowable, locate and correct the faulty work and repeat the test at no cost to the District. Restore the work and all damage resulting from the leak and its repair. Eliminate visible leakage.

3.09 Bulkhead and Test Facility Control

- A. After a satisfactory test, remove the testing fluid, remove test bulkheads and other test facilities, and restore the pipe coatings.

END OF SECTION

SECTION 15056 DUCTILE-IRON PIPE

PART 1 - GENERAL

1.01 Description

- A. This section describes materials, testing, and installation of ductile-iron pipe and fittings 27 inches and smaller.

1.02 Related Work Specified Elsewhere

- A. Trenching, Backfilling, and Compacting: 02223
- B. Fusion-Bonded Epoxy Linings and Coatings: 09811
- C. Painting and Coating: 09900
- D. Piping Schedule and General Piping Requirements: 15000
- E. Disinfection of Piping and Structures: 15041
- F. Pressure Testing of Piping: 15044
- G. Flexible Pipe Couplings: 15122
- H. Corporation Stops and Service Saddles: 15123
- I. Cathodic Protection and Joint Bonding: 16640

1.03 Submittals

- A. Submit shop drawings in accordance with the General Conditions.
- B. Provide an affidavit of compliance with standards referenced in this specification, e.g., AWWA C151.
- C. Provide the following information:
 - 1. Mortar lining thickness.
 - 2. Wall thickness.
 - 3. Show deflections at push-on and mechanical joints.
 - 4. Submit joint and fitting details and manufacturer's data sheets.
- D. Submit calculations and test data proving that the proposed restrained joint arrangement can transmit the required forces with a minimum safety factor of 1.5.
- E. Submit copy of manufacturer's quality control check of pipe material and production.

- F. Submit certification that cement for mortar lining complies with ASTM C150, designating type.
- G. Submit test report on physical properties of rubber compound used in the gaskets.
- H. Submit weld procedure specification, procedure qualification record, and welder's qualifications prior to any welding to ductile-iron pipe.

PART 2 – MATERIALS

2.01 Pipe

Pipe shall be cast ductile (nodular) iron, conforming to AWWA C151. Provide pipe in nominal 18- or 20-foot laying lengths.

2.02 Pipe Marking

Plainly mark each length of straight pipe to identify the design pressure class, the ductile iron wall thickness, and the date of manufacture. Mark the spigot end of restrained joint pipe to show clearly the required depth of insertion into the bell.

2.03 Pipe Wall Thickness

- A. Minimum wall thicknesses for pipe having grooved-end joints as shown in the following table:

Pipe and Fitting Sizes (inches)	Wall Thickness*
16 and smaller	Special Class 53
18	Special Class 54
20	Special Class 55
24 to 27	Special Class 56
*Special Class and Pressure Class per AWWA C151	

- B. Minimum wall thickness for pipe having push-on or mechanical joints, restrained joints, or plain ends, or cast flange ends shall be Special Class 53. Other classes may be considered on an individual case basis by the District if requested.
- C. Minimum wall thickness for pipe having threaded flanges shall be Special Class 53 or Pressure Class 350.
- D. Minimum pipe wall thickness required for corporation stops and tapped outlets shall be in accordance with Table A.1 of AWWA C151 for three full threads for design pressures up to 250 psi and four full threads for design pressures over 250 to 350 psi.

2.04 Fittings

- A. Fittings shall conform to AWWA C110 with a minimum pressure rating of 250 psi. Material shall be cast or ductile iron. Flanges shall be flat faced.

- B. Material for fittings with welded-on bosses shall have a Charpy notch impact value of minimum 10 ft-lbs under the conditions defined in AWWA C151. Test completed welds by the liquid penetrant method per ASTM E165.

2.05 Flanges

- A. Flanges shall be solid back, Class 125 per AWWA C115. Flanges on pipe shall be either cast or threaded. Material shall be ductile iron.
- B. Flanged pipe and fittings shall be shop fabricated not field fabricated. Threaded flanges shall comply with AWWA C115. Flanges shall be individually fitted and machine tightened in the shop, then machined flat and perpendicular to the pipe barrel. Flanges shall be backfaced parallel to the face of flange. Prior to assembly of the flange onto the pipe, apply a thread compound to the threads to provide a leak-free connection. There shall be zero leakage through the threads at a hydrostatic test pressure of 250 psi without the use of the gasket.

2.06 Pipe Lining – Cement Mortar

- A. Line pipe interior and fittings with cement-mortar per AWWA C104. Lining thickness shall be the double thickness listed in AWWA C104, Section 4.7. Cement for lining material shall conform to ASTM C150, Type II.
- B. Line blind flanges per Section 09900, System No. 7
- C. Maintain a moist environment inside the lined pipe and fittings by sealing the ends with polyethylene sheet.
- D. Loose areas of cement-mortar lining are not acceptable. Remove and reconstruct lining in areas where quality is defective, such as sand pockets, voids over sanded areas, blisters, drummy areas, cracked areas, and thin spots. Repair longitudinal cracks in excess of 1/32 inch in width or where crack extends to metal with epoxy. Repair all cracks larger than 1/16 inch with epoxy.

2.07 Grooved-End Couplings

- A. Grooved-end pipe couplings shall be ductile iron, ASTM A536 (Grade 65-45-12). Gaskets shall be EPDM and shall conform to ASTM D2000. Couplings shall be flexible type, square cut groove, per AWWA C606. Couplings for pipe 24-inches in diameter and smaller shall be flexible type, square cut groove, per AWWA C606 and shall be Victaulic Style 77.
- B. Bolts in exposed service shall conform to ASTM A183, 110,000-psi tensile strength. Bolts in buried or submerged service shall be ASTM A193, Grade B8, Class 2.
- C. Couplings for pipe 27 inches and smaller shall conform to AWWA C606 for flexible radius ductile-iron pipe, except where rigid radius couplings are required to connect to fittings.

- D. Grooved-end adapter flanges for piping 27 inches and smaller having an operating pressure of 150 psi and less shall be Victaulic Style 341 or 342 or equal. Flange dimensions shall conform to ASME B16.1, Class 125.
 - E. Groove-end transition couplings for connecting ductile-iron pipe 12 inches and smaller to steel pipe shall be Victaulic Style 307 or equal.
- 2.08 Gaskets for Flanges
- A. See Section 15000.
- 2.09 Gaskets for Mechanical, Push-On, and Restrained Joints
- A. Synthetic or natural rubber in accordance with AWWA C111.
- 2.10 Bolts and Nuts for Flanges
- B. See Section 15000.
- 2.11 Outlets and Nozzles
- A. Provide outlets 2 inches and smaller by tapping the pipe and attaching a service clamp as specified in Section 15123 or use a threaded welded-on boss. Bronze double strap service saddle for exposed, buried, and submerged piping shall be used and shall be Jones J979, Mueller BR2B or equal.
- 2.12 Joints
- A. Joints in aboveground or submerged piping or piping located in vaults and structures shall be flanged.
 - B. Joints in buried piping shall be of the restrained, push-on, or mechanical-joint type per AWWA C111 except where flanged joints are required to connect to valves, meters, and other equipment. Provide unrestrained buried joints except where restrained joints are specifically shown in the drawings.
 - C. Restrained joints for piping 6 inches and larger shall be American Cast Iron Pipe "Lok-Ring" or "Flex-Ring," U.S. Pipe "TR-Flex," or equal.
 - D. Restrained joints in 4-inch-diameter buried piping shall be American Cast Iron Pipe Company "Fast-Grip," U.S. Pipe Field-lok gasket within Tyton joint pipe and fittings, or equal. Joint restraint shall be certified to four times rated pressure of 200 psi by Factory Mutual.
 - E. Where thrust restraint is called for in the drawings, provide pipe with restrained joints capable of transmitting 1.5 times the thrust, as calculated by the following equation:

$$T = 1.5 \times (0.785 \times P \times D^2)$$

Where:

P= Pressure class of pipe in psi.

D = Outside diameter of pipe in inches.

T = Thrust in pounds.

2.13 Ductile-Iron Pipe Weldments

- A. All welding to ductile-iron pipe, such as for bosses, joint restraint, and joint bond cables, shall be done at the place of manufacture of the pipe. Perform welding by skilled welders experienced in the method and materials to be used. Welders shall be qualified under the standard qualification procedures of the ASME Boiler and Pressure Vessel Code, Section IX, Welding Qualifications.
- B. Welds shall be of uniform composition, neat, smooth, full strength, and ductile. Completely grind out porosity and cracks, trapped welding flux, and other defects in the welds in such a manner that will permit proper and complete repair by welding.
- C. Completed welds shall be inspected at the place of manufacture by the liquid penetrant method. Conform to the requirements specified in ASTM E165, Method A, Type I or Type II. The materials used shall be water washable and nonflammable.

PART 3 - EXECUTION

3.01 Delivery, Unloading, and Temporary Storage of Pipe at Site

- A. Limit onsite pipe storage to a maximum of one week.
- B. Use unloading and installation procedures that avoid cracking of the lining. If necessary, use plastic sheet bulkheads to close pipe ends and keep cement-mortar lining moist.
- C. Deliver the pipe alongside the pipelaying access road over which the pipe trailer-tractors can travel under their own power. Place the pipe in the order in which it is to be installed and secure it from rolling.
- D. Do not move pipe by inserting any devices or pieces of equipment into the pipe barrel. No field repair of linings damaged by unloading or installation procedures will be permitted; replace the defective pipe or fitting.

3.02 Sanitation of Pipe Interior

- A. During laying operations, do not place tools, clothing, or other materials in the pipe.
- B. When pipelaying is not in progress, close the ends of the installed pipe by a vermin-proof

plug.

3.03 Installing Flanged Pipe and Fittings

- A. Install in accordance with Section 15000. Cut the bore of the gaskets such that the gaskets do not protrude into the pipe when the flange bolts are tightened.

3.04 Installing Groove-End Pipe and Fittings

- A. See Section 15000.

3.05 Installing Buried Piping

- A. Install in accordance with Section 02223 and as follows.
- B. For all field cut-to-fit joints, do not stress or deflect the pipe when mating pipe ends.

3.06 Chlorination of Potable Waterlines

- A. See Section 15041.

3.07 Joint Deflections for Buried Pipe

- A. Do not exceed the following deflection angles for unrestrained buried pipe joints:

Pipe Sizes (inches)	Maximum Deflection (degrees)	
	Push-On Joint	Mechanical Joint
4	4	6 1/2
6	4	5 1/2
8	4	4
10	4	4
12	4	4
14	2 1/2	3
16	2 1/2	3
18	2 1/2	2 1/2
20	2 1/2	2 1/2
24-27	2 1/2	2

- B. For restrained joints, do not exceed 80% of the manufacturer's recommended maximum deflections.
- C. Deflections in pipes and joints shall not exceed manufacturer recommendations. Small angular changes (less than 7 degrees) in horizontal alignment defined in the drawings by a point of inflection (PI) with no accompanying curve data shall be approximated as a curve by deflecting by equal amounts equal length pipe segments to create a curve equally distributed on both sides of the given PI. Accomplish a larger (greater than or equal to 7 degrees) change in horizontal alignment where a curve is not called for in the drawings through the use of an elbow placed at the station of the PI shown in the drawings. Provide thrust restraint as required in the Standard Drawings.

- D. Small angular changes (less than 5 degrees) in vertical alignment may be accomplished by the use of pulled joints. For larger vertical deflections, place an elbow at the station and elevation of the vertical PI shown in the drawings. Provide thrust restraint as required in the Standard Drawings.
- E. Assemble joints in accordance with AWWA C600 and the manufacturer's recommendations.

3.08 Painting and Coating

- A. Furnish exposed pipe located above ground and in vaults and structures without standard asphaltic coating. Exposed pipe shall be shipped to site with factory primer compatible with finish coating system. Applying coatings over asphaltic coatings is not allowed.
- B. Coat pipe located above ground and in vaults and structures per Section 09900, System No.15. Coat pipe located in vaults per Section 09900, System 12 in the shop before transporting pipe to the jobsite. Apply finish coats in the field before installing the pipe, then touch up after installation.
- C. Provide asphaltic coating on buried pipe per AWWA C151.
- D. Coat buried flanges and buried mechanical and restrained joint bolts, nuts, and glands per Section 09900, System No. 21.
- E. Coat submerged pipe with fusion-bonded epoxy per Section 09811.

3.09 Polyethylene Encasement of Pipe and Fittings

- A. Wrap buried pipe, fittings, grooved-end couplings, and joints with polyethylene per AWWA C105. Care must be taken to ensure no cuts, tears, or pin holes in polyethylene wrap prior to or after backfill. Wrap polyethylene tubing joints with 2-inch-wide adhesive tape: Polykeo 900, Scotchwrap 50, or equal.

3.10 Interior Joint Recesses for Buried Piping 30-inches and Larger

- A. Pack interior joint recesses of 30-inch and larger nominal diameter pipes with cement-mortar. Do not pack interior joints until after backfilling the pipe section.
- B. Working inside the pipe, remove foreign substances from joint recesses and pack with cement-mortar. Finish the surface with a steel trowel to match adjoining pipe.

3.11 Cleaning Pipe

- A. After interior joints have been packed and mortar has hardened, sweep pipe clean of all dirt and debris. If hardened mud exists in the pipe, remove with the use of pressurized water hoses.

3.12 Field Hydrostatic Testing

A. Test pressures are shown in test in accordance with Section 15044.

END OF SECTION

DRAFT

SECTION 15057 COPPER TUBING

PART 1 - GENERAL

1.01 Description

A. This section includes material, installation, and testing of copper tubing and fittings.

B. Related Work Specified Elsewhere

1. Trenching, Backfilling, and Compacting: 02223
2. Painting and Coating: 09900
3. Piping Schedule and General Piping Requirements: 15000
4. Disinfection of Piping and Structures: 15041
5. Pressure Testing of Piping: 15044
6. Manual, Check, and Process Valves: 15100

C. Submittals

1. Submit shop drawings in accordance with the General Conditions.
2. Submit materials list showing material of tubing and fittings with ASTM reference and grade.
3. Submit manufacturer's catalog data and descriptive literature for wye strainers, unions, and coatings.
4. Submit manufacturer's catalog data and descriptive literature for solder.

PART 2 – MATERIALS

2.01 Tubing

A. Buried tubing or tubing located beneath floor slabs shall be Type K, annealed.

2.02 Solder Joint Fittings

- A. Wrought copper solder joint seamless fittings shall be designed for use with copper water tube and conform to ASTM B75 and ASME B16.22.
- B. Cast copper solder joint pressure fitting shall be designed for use with copper water tube and conform to ANSI B16.18.

2.03 Threaded Fittings

- A. Cast bronze threaded fittings shall be designed for use with copper or brass pipe and nipples and conform to ANSI B16.15, Classes 125 and 250. Use Class 125 fittings for working pressures of 200 psi and less. Use Class 250 fittings for working pressures of greater than 200 psi but less than 400 psi.

2.04 Nut and Ferrule Fittings

- A. Fittings shall be brass and of the Swagelok type as manufactured by Crawford Fitting Company, utilizing a nut and dual ferrule design to connect to tubing. End connections shall be of the union type.

2.05 Solder

- A. Solder shall be tin-silver solder conforming to ASTM B32.

2.06 Pipe and Nipples

- A. Short threaded nipples and pipe shall be brass conforming to ASTM B43 or copper conforming to ASTM B42, regular wall thickness, except that nipples and pipe of sizes 1 inch and smaller shall be extra strong. Threads shall conform to ASME B1.20.1.

2.07 Bolts and Nuts for Flanges

- A. See Section 15000.

2.08 Gaskets for Flanges

- A. See Section 15000

EXECUTION – PART 3

3.01 Joint and Fitting Selection

- A. For new installations, copper fittings shall be copper conforming to ASTM B75 and ANSI B16.22, with solder end joints.
- B. For repairs, use compression joints and fittings in buried tubing service, except that fittings and joints 3/8 inch and smaller in exposed service may be of the nut and ferrule type with compression joint connections.
- C. Use compression joints and fittings in buried copper and brass piping.

3.02 Pressure Testing

- A. Test copper piping for leakage in accordance with Section 15044.

3.03 Installing Flange Bolts and Nuts

- A. See Section 15000.

3.04 Installation

- A. Do not drag tubing out of tubing rack. Do not drag tubing across cement, asphalt, gravel, or any other surface that could scratch it.
- B. Tube cutters shall always be sharp. Do not take too deep a cut with each turn of the cutter or back and forth motion.
- C. Cut tubing square and remove burrs inside and outside the pipe. Clean both the inside and outside of fitting and pipe ends with steel wool and muriatic acid before soldering. Prevent annealing of fittings and tubing when making connections. Do not miter joints for elbows or notch straight runs of pipe for tees.
- D. Bends in soft copper tubing shall be long sweep. Shape bends with shaping tools. Form bends without flattening, buckling, or thinning the tubing wall at any point.
- E. Brazing procedures shall be in accordance with Articles XII and XIII, Section IX, of the ASME Boiler and Pressure Vessel Code. Solder shall penetrate to the full depth of the cup in joints and fittings. Solders shall comply with ANSI B31.3, paragraph 328.
- F. Install tube and pipe without springing, forcing, or stressing the pipe or any adjacent connecting valves or equipment.
- G. Clean threaded joints by wire brushing or swabbing. Apply Teflon joint compound or Teflon tape to male pipe threads before installing threaded fitting. Joints shall be watertight.
- H. Install buried tubing in accordance with Section 02223.

3.05 Connecting Copper Tubing to Steel and Ductile-Iron Pipe

- A. Provide an insulating union at the point of transition from copper tubing or piping to ferrous piping.
- B. Nylon bushings shall not be used unless approved by the District Engineer.

3.06 Chlorination of Potable Waterlines

- A. See Section 15041.

END OF SECTION

DRAFT

SECTION 15064 PVC DISTRIBUTION PIPE (AWWA C900)

PART 1 - GENERAL

1.01 Description

- A. This section includes materials, installation, and testing of polyvinyl chloride (PVC) distribution pipe conforming to AWWA C900. Size range is 4 through 27 inches.

1.02 Related Work Specified Elsewhere

- A. Trenching, Backfilling, and Compacting: 02223
- B. Painting and Coating: 09900
- C. Fusion-Bonded Epoxy Linings and Coatings: 09811
- D. Piping Schedule and General Piping Requirements: 15000
- E. Disinfection of Piping: 15041
- F. Pressure Testing of Piping: 15044
- G. Flexible Pipe Couplings: 15122
- H. Corporation Stops and Service Saddles: 15123

1.03 Submittals

- A. Submit shop drawings in accordance with the General Conditions.
- B. Provide affidavit of compliance with AWWA C900.
- C. Submit fully dimensioned cross section of the bell and barrel of the pipe. Show the bell maximum outside diameter in the pressurized area and its minimum wall thickness at the same location.
- D. Submit copies of the following manufacturer-required tests conducted on project pipe:
 - 1. Quick-burst strength of pipe and couplings.
 - 2. Flattening resistance of pipe.
 - 3. Record of additional tests after test sample failure.
- E. Submit manufacturer's literature of gray iron and ductile-iron fittings, including dimensions, thickness, weight, coating lining, and a statement of inspection and compliance with the acceptance tests of AWWA C110. Submit copy of report of pressure tests for qualifying the designs of all sizes and types of AWWA C153 fittings that are being used in the project. The pressure test shall demonstrate that the minimum safety factor described in AWWA C153, Section 53-15 is met.

- F. Submit online drawings and material description of service connection saddles, corporation stops, and pipe plugs.

PART 2 - MATERIALS

2.01 Pipe

- A. Pipe shall conform to DR 14 in accordance with AWWA C900, rubber-ring gasket bell end or plain end with elastomeric gasket coupling, Class 150 or Class 200 as shown in the drawings, cast iron equivalent OD, material cell classification 12454-B per ASTM D 1784.

2.02 Fittings

- A. Fittings shall conform to AWWA C110 with a minimum pressure rating of 250 psi. Size bells specifically for outside diameter of cast iron equivalent PVC pipe including rubber-ring retaining groove.
- B. Fittings conforming to AWWA C153 may be used in sizes approved by the District. Tees conforming to AWWA C153 may be used in the following size ranges:

Run Size (inches)	Maximum Branch Size (inches)
3	3
4	4
6	3
8, 10, 12	4

2.03 Flanges

- A. Flanges on outlets of fittings shall be Class 125 per ASME B16.1.

2.04 Lining and Coating for Fittings

- A. Provide cement- mortar lined fittings per AWWA C104. Lining thickness shall be the double thickness listed in AWWA C104, Section 4.8. Cement lining shall conform to ASTM 150, Type II. Coating fittings shall be installed per Section 099000 System No. 21.
- B. Alternatively, line fittings per Section 09900, System No. 7.
- C. Coat fittings per Section 09900, System No. 23.
- D. Alternatively, line and coat fittings with fusion-bonded epoxy per Section 09811.

2.05 Gaskets for Flanges

- A. See Section 15000.

2.06 Bolts and Nuts for Flanges

B. See Section 15000.

2.07 Outlets and Nozzles

A. Provide outlets 2 inches and smaller by attaching a service clamp as specified in Section 15123.

B. For outlets larger than 2 inches, use a tee with a flanged outlet.

2.08 Flanged Coupling Adapters

A. See Section 15122.

PART 3 - EXECUTION

3.01 Product Marking

A. Legibly mark pipe at 5-foot intervals and each coupling to identify the nominal diameter, the OD base, that is, cast-iron or steel pipe (IPS), the material code for pipe and couplings, the dimension ratio number, AWWA C900, and the seal of the testing agency that verified the suitability of the material for potable water services (NSF in the United States).

3.02 Delivery and Temporary Storage of Pipe

A. Ship, store, and place pipe at the installation site, supporting the pipe uniformly. Avoid scratching the pipe surface. Do not stack higher than 4 feet nor stack with weight on bells. Cover to protect from sunlight.

3.03 Pipe Layout for Curved Alignment

A. Pipe lengths may be bent for curved alignment but to no smaller radius curve than the following:

Pipe Diameter	Minimum Curve Radius
4-inch	400 feet
8-inch	600 feet
10-inch	800 feet
12-inch	1,000 feet
16-inch	1,200 feet

Curve radius shall be governed by pipe manufacturer for pipes larger than 16 inches.

3.04 Handling Pipe

A. Hoist pipe with mechanical equipment using a cloth belt sling or a continuous fiber rope that avoids scratching the pipe. Do not use a chain. Pipes up to 12 inches in diameter may be lowered by rolling on two ropes controlled by snubbing. Pipes up to 6 inches in diameter may be lifted by hand.

3.05 Installing Buried Pipe

- A. Install in accordance with AWWA C605, Section 02223 and as follows.
- B. Backfill materials in the pipe zone shall be imported sand per Section 02223. Do not add successive layers unless the previous layer is compacted to 95% relative compaction per ASTM D1557.
- C. Compact material placed within 12 inches of the outer surface of the pipe by hand tamping only.
- D. Compact trench backfill to the specified relative compaction. Compact by using mechanical compaction, water jetting, or hand tamping. Do not float pipe. Do not use high-impact hammer-type equipment except where the pipe manufacturer warrants in writing that such use will not damage the pipe.

3.06 Assembly of Pipe Joint

- A. The spigot and bell or bell coupling shall be dirt free and slide together without displacing the rubber ring.
- B. Lay the pipe section with the bell coupling facing the direction of laying.
- C. Insert the rubber ring into the groove in the bell in the trench just before joining the pipes. First clean the groove. Observe the correct direction of the shaped ring. Feel that the ring is completely seated.
- D. Lubricate the spigot over the taper and not past full insertion mark with the lubricant supplied by the pipe manufacturer. If the lubricated pipe end touches dirt, clean the pipe end and reapply lubricant.
- E. Insert the spigot into the bell and force it slowly into position up to insertion mark.
- F. Check that the rubber ring has not left the groove during assembly by passing a feeler gauge around the completed joint.

3.07 Wrapping Fittings

- A. Wrap buried cast-iron fittings with polyethylene per Section 15056.
- B. PVC pipe shall be inserted per the manufacturer's recommendations up to the maximum insertion line, but not beyond to assure visibility.

3.08 Field Hydrostatic Testing

- A. Test in accordance with Section 15044.

3.09 Disinfection

- A. See Section 15041

END OF SECTION

DRAFT

SECTION 15100 MANUAL, CHECK, AND PROCESS VALVES

PART 1 - GENERAL

1.01 Description

- A. This section includes materials, testing, and installation of manually operated valves, check valves, and process valves including gate, butterfly, and ball valves.

1.02 Related Work Specified Elsewhere

- A. Fusion-Bonded Epoxy Linings and Coatings: 09811
- B. Painting and Coating: 09900
- C. Piping Schedule and General Piping Requirements: 15000
- D. Pressure Testing of Piping: 15044
- E. Air-Release and Vacuum-Relief Valves: 15108
- F. Fire Hydrants: 15109
- G. Detector Check Valves: 15112

1.03 Submittals

- A. Submit shop drawings in accordance with the General Conditions.
- B. Submit manufacturer's catalog data and detail construction sheets showing all valve parts. Describe each part by material of construction, specification (such as AISI, ASTM, SAE, or CDA), and grade or type.
- C. Show valve dimensions including laying lengths. Show port sizes. Show dimensions and orientation of valve actuators, as installed on the valves. Show location of internal stops for gear actuators. State differential pressure and fluid velocity used to size actuators. For worm gear actuators, state the radius of the gear sector in contact with the worm and state the handwheel diameter.
- D. Show valve linings and coatings. Submit manufacturer's catalog data and descriptive literature.
- E. Submit one hard copy and one electronic copy of a report verifying that the valve interior linings and exterior coatings have been tested for holidays and lining thickness. Describe test results and repair procedures for each valve. Do not ship valves to project site until the reports have been returned by the Owner's Representative and marked "Resubmittal not required."
- F. For butterfly valves, show the clear diameter or size of the port. Show the actual area of the port as a percentage of the area as calculated for the nominal valve size.

1.04 Proof of Design Test for Eccentric Plug Valves

- A. The Contractor shall require the valve manufacturer to furnish one hard copy and one electronic copy of reports covering the design tests for the eccentric plug valves as described in AWWA C517 and the following. One prototype valve of each size and class of a manufacturer's design shall be tested for leakage at the specified design pressure and hydrostatically tested with twice the specified design pressure. The hydrostatic test shall be performed with the plug in the open position. The leakage test shall be performed with the plug in the closed position. The duration of each test shall be 10 minutes minimum. During the leakage test, there shall be no indication of leakage past the valve plug. Valves specified to have bi-directional seats shall be leak tight in both directions. In the case of flanged valves, the valve body shall be bolted to a flanged test head.
- B. No part of the valve or plug shall be permanently deformed by the hydrostatic test. During the hydrostatic test, there shall be no leakage through the metal, the end joints, or the shaft seal.
- C. It is the intent that the valve manufacturer provides evidence of the adequacy of each type offered to perform under design pressures within the applicable rating for a sufficient number of test cycles simulating a full service life. The adequacy is to be proven by tests, made on one or more valves selected to represent each basic type of seat design of a size within each applicable group, in a pressure class or classes equal to or greater than that specified. The required number of test cycles appears in the following table:

TEST CYCLES REQUIRED		
Size Group (inches)	No. of Cycles	Minimum Differential Pressure (psig)
3 to 20	10,000	150
24 to 27	5,000	150

Every test cycle shall consist of applying the specified differential pressure to the plug in the closed position, then opening the plug (which will relieve the pressure) to the wide-open position and then closing the plug.

- D. The valve shall be leak tight under the specified pressure differential upon completion of the cycle test without having to stop during the test to repair the valve, modify or reinforce the seat, or install shims or wedges around the seat.
- E. The plug shall not be rotated past the center position to jam the plug onto the seat during the hydrostatic test, the leakage test, or the cycle test.

PART 2 – MATERIALS

2.01 General

- A. Install valves complete with operating handwheels or levers, extension stems, gear actuators, operating nuts, and wrenches required for operation.
- B. Valves shall have the name of the manufacturer and the size of the valve cast or molded onto the valve body or bonnet or shown on a permanently attached plate.

2.02 Valve Actuators

- A. Provide lever or wrench actuators for exposed valves smaller than 6 inches. For larger valves, provide handwheels.
- B. Provide 2-inch AWWA operating nuts for buried and submerged valves.
- C. Provide enclosed gear actuators on butterfly 6 inches and larger. Gear actuators for valves 6 inches through 20 inches shall be of the worm and gear, or of the traveling nut type. Gear actuators for valves 24 inches and larger shall be of the worm and gear types.
- D. Provide gear actuators on gate valves 14 inches and larger. Gear actuators shall be of the bevel or spur gear type. Provide grease case. Gearing shall comply with AWWA C500.
- E. Design gear actuators assuming that the differential pressure across the plug or disc is equal to the pressure rating of the valve and assuming a line fluid temperature range of 50°F to 100°F unless otherwise required in the detailed valve specifications.
- F. Gear actuators shall be enclosed, oil lubricated, with seals provided on shafts to prevent entry of dirt and water into the actuator. Gear actuators for valves located above ground or in vaults and structures shall have handwheels. The actuators for valves in exposed service shall contain a dial indicating the position of the valve disc or plug. Gear actuators for buried or submerged valves shall have 2-inch-square AWWA operating nuts.
- G. For buried or submerged service, provide watertight shaft seals and watertight valve and actuator cover gaskets. Provide totally enclosed actuators designed for buried or submerged service.
- H. Traveling nut and worm and gear actuators shall be of the totally enclosed design so proportioned as to permit operation of the valve under full differential pressure rating of the valve with a maximum pull of 80 pounds on the handwheel or crank. Provide stop limiting devices in the actuators in the open and closed positions. Actuators shall be of the self-locking type to prevent the disc or plug from creeping. Design actuator components between the input and the stop-limiting devices to withstand without damage a pull of 200 pounds for handwheel or chainwheel actuators and an input torque of 300 foot-pounds for operating nuts when operating against the stops.
- I. Handwheel diameters for traveling nut actuators shall not exceed 8 inches for valves 12 inches and smaller and shall not exceed 12 inches for valves 20 inches and smaller.
- J. Self-locking worm gear shall be a one-piece design of gear bronze material (ASTM B 427; or ASTM B 584, Alloy C86200), accurately machine cut. The worm shall be

hardened alloy steel (ASTM A 322, Grade G41500 or G41400; or ASTM A 148, Grade 105-85), with thread ground and polished. Support worm gear shaft at each end by ball or tapered roller bearings. The reduction gearing shall run in a proper lubricant. The handwheel diameter shall be no more than twice the radius of the gear sector in contact with the worm. Worm gear actuators shall be provided by manufacturer.

- K. Design actuators on buried valves to produce the required torque on the operating nut with a maximum input of 150 foot-pounds.
- L. Valve actuators, handwheels, or levers shall open by turning counterclockwise.

2.03 Cast-Iron Valve Boxes for Buried Valves

- A. Valve boxes shall be two-piece sliding type, cast iron, with extension shafts as shown on the Standard Drawings. Units shall be Bingham and Taylor 10-inch GRE10R-TF cast iron valve box and triangle cover, non-locking lid. Extension pipes shall be PVC SDR 35. Coat buried cast-iron pieces per Section 09900, System No. 21 with fusion bonded epoxy per Section 09811.

2.04 Extension Stems for Buried and Submerged Valve Actuators

- A. Where the depth of the valve is such that its centerline is more than 4 feet below grade, provide operating extension stems to bring the operating nut to a point 6 inches below the surface of the ground and/or box cover. Where the valve is submerged, provide operating extension stems to bring the operating nut to 6 inches above the water surface. Extension stems shall be stainless steel, solid core, and shall be complete with 2-inch-square operating nut. The connections of the extension stems to the operating nuts and to the valves shall withstand without damage a pull of 300 foot-pounds.

Valve Size (inches)	Minimum Extension Stem Diameter (inches)
2	3/4
3,4	7/8
6	1
8	1-1/8
10, 12	1-1/4
14	1-3/8
16, 18	1-1/2
20, 24	1-3/4

2.05 Chainwheels and Guides

- A. Chainwheels and guides shall be Clow Figure F-5680, DeZurik Series W or LWG, Stockham, or equal. Chainwheels and guides shall be galvanized iron or steel or aluminum. Chains shall extend to within 4 feet of the operating floor. Chains shall be galvanized steel.

2.06 Bolts and Nuts for Flanged Valves

- A. Bolts and nuts for flanged valves shall be as described in Section 15000.

2.07 Gaskets for Flanges

- A. Gaskets for flanged end valves shall be as described in Section 15000.

2.08 Painting and Coating

- A. Coat metal valves located above ground or in structures in accordance with Section 09900, System No. 15. Coat valves located in vaults in accordance with Section 09900, System 12. Apply the specified prime coat at the place of manufacture. Apply intermediate and finish coats in field. Finish coat shall match the color of the adjacent piping. Coat handwheels the same as the valves.
- B. Coat buried metal valves at the place of manufacture per Section 09900, System No. 21.
- C. Line the interior metal parts of metal valves 4 inches and larger, excluding seating areas and bronze and stainless-steel pieces, per Section 09900, System No 7. Apply lining at the place of manufacture.
- D. Alternatively, line and coat valves with fusion-bonded epoxy per Section 09811.
- E. Test the valve interior linings and exterior coatings at the factory with a low-voltage (22.5 to 80 volts, with approximately 80,000-ohm resistance) holiday detector, using a sponge saturated with a 0.5% sodium chloride solution. The lining shall be holiday free.
- F. Measure the thickness of the valve interior linings per Section 09900. Repair areas having insufficient film thickness per Section 09900.

2.09 Packing, O-Rings, and Gaskets

Unless otherwise stated in the detailed valve specifications, packing, O-rings, and gaskets shall be one of the following non-asbestos materials:

- A. Teflon.
- B. Kevlar aramid fiber.
- C. Acrylic aramid fiber bound by nitrile. Products: Garlock "Bluegard," Klinger "Klingersil C4400," or equal.
- D. Buna-N (nitrile).

2.10 Rubber Seats

- A. Rubber seats shall be made of a rubber compound that is resistant to free chlorine and monochloramine concentrations up to 10 mg/l in the fluid conveyed.

2.11 Valves

- A. Gate Valves:

1. Aboveground Gate Valves 3 Inches and Smaller:

Aboveground threaded end gate valves, 1/4 inch through 3 inches, for water and air service shall be rising stem, screwed or union bonnet, solid wedge disc type, Class 125, having a minimum working pressure of 200 WOG psi at a temperature of 150°F. Ends shall be female threaded, ANSI B1.20 1. Materials of construction shall be as follows:

Component	Material	Specification
Body, bonnet	Bronze	ASTM B 61 or B 62
Disc	Bronze	ASTM B 61, B 62, or B 584 (Alloy C97600)
Stem	Bronze or copper silicon	B 99 (Alloy 651), B 584 (Alloy C87600), B 371 (Alloy C69400)
Seat Rings (Classes 200 and 300 only)	Stainless Steel	AISI Type 410

Handwheels shall be aluminum, brass, or malleable iron. Packing shall be Teflon or Kevlar aramid fiber. Valves shall be Crane 428, Stockham B-100, or equal.

2. Tapping Gate Valves 3 Through 24 Inches:

Valves shall conform to AWWA C500 and the following. Valves shall be iron bodied, solid bronze internal working parts, parallel faced, bottom wedging double-discs, and O-ring seals. Discs shall be solid bronze. The minimum designated water working pressure shall be 200 psi for valves 3 inches through 12 inches. Bronze for internal working parts, including stems, shall not contain more than 2% aluminum nor more than 7% zinc. Bronze shall conform to ASTM B 62 or ASTM B 584 (Alloy C83600), except that stem bronze shall have a minimum tensile strength of 60,000 psi, a minimum yield strength of 30,000 psi, and a minimum of 10% elongation in 2 inches (ASTM B 584, Alloy C87600). Body bolts shall be Type 316 stainless steel, ASTM A 276. Ends shall be flanged, Class 125, ANSI B16.1. One end shall have slotted bolt holes to fit tapping machines. Seat rings shall be oversized to permit the use of full-size cutter. Valves shall be Clow, Mueller, American-Darling, Stockham, or equal.

3. Gate Valves 4 Inches Through 12 Inches, Class 250:

Valves shall be iron body, bronze mounted, nonrising stem, bolted bonnet, solid wedge disc, with Teflon packing. Minimum nonshock working pressure shall be 500 psi. Materials of construction shall be as follows:

Component	Material	Specification
Bodies and discs	Cast iron	ASTM A126, Class B
Disc bushing, disc ring, seat bushing, and seat ring	Bronze	ASTM B62
Stem	Bronze	ASTM B371, B584, or B763 (Alloys C69400, C86200, C86300, C86400, C86500, C86700, C87600, C87500, C99500)
Body bolts and nuts	Stainless steel	ASTM A276, Type 316

Ends shall be flanged, Class 250, ANSI B16.1. Valves shall be Stockham Figure F-661, Crane 3E, Walworth Figure 8775F, or equal.

4. Resilient Wedge Gate Valves 3 Inches Through 12 Inches:

Valves shall comply with AWWA C509 and the following: The minimum rated working pressure shall be 200 psi. Valves shall have non-rising stems. Valve stems shall be cast, forged, or rolled bronze. Stem nuts shall be made of solid bronze. Bronze for internal working parts, including stems, shall not contain more than 2% aluminum nor more than 7% zinc. Bronze shall conform to ASTM B62 or ASTM B584 (Alloy C83600), except the stem bronze shall have a minimum tensile strength of 60,000 psi, a minimum yield strength of 30,000 psi, and a minimum of 10% elongation in 2 inches (ASTM B 584 or B 763, Alloy C87600 or C99500). Body bolts shall be 316 stainless steel. Cast-iron wedge shall have sealing surfaces of the wedge permanently bonded with resilient material to meet ASTM tests for rubber to metal bond, ASTM D429.

Provide reduction thrust bearings above the stem collar. Stuffing boxes shall be O-ring seal type with two rings located in stem above thrust collar. Each valve shall have a smooth unobstructed waterway free from any sediment pockets.

Valves shall be lined and coated at the place of manufacture with either fusion-bonded epoxy or heat-cured liquid epoxy. Minimum epoxy thickness shall be 8 mils.

Valve shall be Clow R/W, AVK, American Darling CRS-80, Waterous Series 500, Kennedy Ken-Seal, or equal.

B. Butterfly Valves:

1. Thrust Bearings for Butterfly Valves

Provide thrust bearings to hold the valve disc in the center of the valve seat. No bearings

shall be mounted inside the valve body within the waterway. Do not use thrust bearings in which a metal bearing surface on the disc rubs in contact with an opposing metal surface on the inside of the body.

2. Bronze Components in Butterfly Valves:

Bronze components in contact with water shall comply with the following requirements:

Constituent	Content
Zinc	7% maximum
Aluminum	2% maximum
Lead	Lead-Free in accordance with NSF/ANSI 372
Copper + Nickel + Silicon	83% minimum

3. Actuator Sizing for Butterfly Valves:

Actuators shall be sized to produce output torque values as listed in Table 4 of AWWA C504.

4. Port Sizes for Butterfly Valves

For valves 24 inches and smaller, the actual port diameter shall be at least 93% of the nominal valve size. For valves larger than 24 inches, the port diameter shall not be more than 1.25 inches smaller than the nominal valve size. The dimension of the port diameter shall be the clear waterway diameter plus the thickness of the rubber seat.

5. Corrosion-Resistant Materials in Butterfly Valves

Where AWWA C504 requires “corrosion resistant” material, such material shall be one of the following:

- a. Bronze as described above.
- b. Type 304 or 316 stainless steel.
- c. Monel (UNS N04400).
- d. Synthetic nonmetallic material.

6. Seating Surfaces in Butterfly Valves

Seating surfaces shall be stainless steel or nickel-copper per AWWA C504 or nickel-chromium alloy containing a minimum of 72% nickel and a minimum of 14% chromium.

7. Butterfly Valves 4-inches and Larger, Class 150B:

Butterfly valves shall be short body, flanged type for exposed valves and valves in vaults or structures, and either flanged or mechanical joint for buried valves. Valve shall conform to AWWA C504, Class 150B. Minimum working differential pressure across the valve disc shall be 150 psi. Flanged ends shall be Class 125, ASME B16.1. Valve shafts shall be stub shaft or one-piece units extending completely through the valve disc. Materials of construction shall be as follows:

Component	Material	Specification
Body	Cast iron or ductile iron	AWWA C504
Exposed body cap screws and bolts and nuts	Stainless steel	ASTM A276, Type 304 or 316
Discs	Cast iron, ductile iron, or Ni-Resist	AWWA C504
Shafts, disc fasteners, seat retention segments, and seat fastening devices	Stainless steel	ASTM A276, Type 304 or 316
Seat material	Buna-N	—

Where the rubber seat is applied to the disc, it shall be bonded to a stainless-steel seat retaining ring which is clamped to the disc by Type 304 or 316 stainless-steel screw fasteners. Valves shall be Pratt, DeZurik Figure 670, or equal.

8. Butterfly Valves 4 Inches and Larger, Class 250:

Butterfly valves shall be short body, flanged type for exposed valves and valves in vaults or structures, and either flanged or mechanical joint for buried valves. Flanged ends shall be Class 250, ANSI B16.1. Valve shafts shall be stub shaft or one-piece units extending completely through the valve disc. The rubber valve seats shall be secured to or retained in the valve body. Materials of construction shall be as follows:

Component	Material	Specification
Body	Cast iron or ductile iron	AWWA C504
Exposed body cap screws and bolts and nuts	Stainless steel	ASTM A276, Type 304 or 316
Shaft	Stainless steel	ASTM A564, Grade S17400
Discs	Cast iron, ductile iron, or Ni-Resist	ASTM A 48, Class 40; ASTM A 536, Grade 65-45-12; ASTM A 436, Type 1; ASTM A 126, Class B; or ASTM A 743, Grade CF8M
Disc fasteners, seat retention segments, and seat fastening devices	Stainless steel	ASTM A276, Type 304 or 316
Seat material	Buna-N	—

Valves shall be Pratt, American-Darling, or equal.

C. Ball Valves:

1. Bronze Ball Valves 2 Inches and Smaller:

Ball valves, 2 inches and smaller, for air or water service shall be all bronze (body, ball, stem, and plug ball retainer), ASTM B 62. Provide chrome-plated ball. Valves shall have screwed ends (ANSI B1.20.1), nonblowout stems, reinforced Teflon seats, and have plastic-coated lever operators. Valves shall have a pressure rating of at least 600 psi WOG at a temperature of 150°F. Valves shall be Stockham S-217, Lunkenheimer Figure 707, Apollo 77-100 Series, or equal.

D. Globe and Angle Valves

1. Angle Hose Valves

Angle-type hose valves of sizes 1-1/2 inches and 2-1/2 inches shall be brass or bronze (ASTM B 62) body with rising and nonrising stem, composition disc, and bronze or malleable iron handwheel. Stem shall be bronze, ASTM B 62 or ASTM B 198 (Alloy C87600). Valves shall have a cold-water service pressure rating of at least 150 psi. Provide cap and chain with valve. Threads on the valve outlet shall be American National Standard fire hose coupling screw thread. Valves shall be Nibco T-301-HC, Powell Figure 151 with Figure 527 nipple adapter, Crane 17TF with hose nipple adapter, or equal.

E. Hose Bibbs

Hose bibbs of size 1/2 inch, 3/4 inch, and 1 inch shall be all bronze (ASTM B 62) with rising

or nonrising stem, composition disc, bronze or malleable iron handwheel, and bronze stem (ASTM B 99, Alloy 651; ASTM B 371, Alloy C69400; or ASTM B 584, Alloy C87600). Packing shall be Teflon or graphite. Valves shall have a pressure rating of at least 125 psi for cold-water service. Threads on valve outlet shall be American National Standard fire hose coupling screw thread (ANSI B2.4). Provide vacuum breaker approved the County of Orange health department on each hose bibb. Valves shall be Jenkins Figure 112, 113, or 372, Nibco Figure T-113-HC, Powell Figure 503H, or equal.

F. Check Valves

1. Bronze Check Valves 3 inches and Smaller:

Check valves 3 inches and smaller shall be Class 125, wye pattern, bronze, ASTM B 61 or B 62. Ends shall be female threaded, ANSI B1 20.1. Disc shall be bronze, swing type. Minimum working pressure shall be 200 psi WOG at a temperature of 150°F. Valves shall be Crane No. 37, Nibco T-413-B, Stockham B-319, or equal.

2. Swing Check Valves 3 Inches and Larger, Class 125:

Swing check valves, 3 inches and larger, shall be iron body, bronze mounted with the following materials of construction:

Description	Material	Specification
Disc or clapper seat ring and valve body seat ring	Bronze or brass	ASTM B62 or B584 (Alloy C84400 or C87600)
Body and cap (bonnet)	Cast iron	ASTM A126, Class B
Disc and hinge or arm (valves 4 inches and smaller)	Bronze	ASTM B62 or ASTM B584 (Alloy C84400)
Disc and hinge or arm (valves larger than 4 inches)	Cast iron or bronze	ASTM A126, Class B; ASTM B62.
Hinge pin	Stainless steel	Type 303, 304, or 410 stainless
Cover bolts and nuts	Stainless steel	ASTM A193, Grade B8M; ASTM A194, Grade 8M
Internal fasteners and accessories	Bronze or Type 304 or 316 stainless steel	

Ends shall be flanged, Class 125, ASME B16.1 Minimum valve working pressure shall be 150 psi. Provide check valves with outside lever and spring.

The shop drawing submittal shall include a detail showing how the hinge pin extends through the valve body. Show packing gland, hinge pin gland, cap, and other pieces utilized.

Valves shall be Clow F-5381, or equal.

3. Wafer Single-Disc Check Valves, Class 125:

Wafer single-disc check valves shall conform to API 594 and API D6 and shall be designed to be installed between the flanges of the adjoining pipe. Valve shall be equipped with an external spring mechanism to provide for nonslam closure of the valve without backflow, in any position, and shall not be dependent on gravity or backflow for closure. Provide a top-mounted flushing port with plug; coat plug threads with Teflon-paste lubricating compound prior to insertion. Spring mechanism shall be external and adjustable. Shaft packing shall be Teflon, externally adjustable and replaceable. Materials of construction shall be as follows:

Component	Material	Specification
Body, spring arm, and flush port plug	Carbon steel	ASTM A36 or A216, Grade WCB
Disc	Stainless steel	ASTM A240, Type 316
Disc arm, disc arm key, spring arm key, and spring seat ring	Stainless steel	ASTM A313 or A479, Type 316
Follower, gland bottom, inner bushing, bushing, retainer washer, and outer bushing	Bronze	ASTM B584, Alloy C93200
Shaft	Stainless steel	ASTM A351, Grade CF8M
Shaft packing	Braided Teflon	—
Shaft seals and seat outside diameter seal	Buna-N	—

PART 3 – EXECUTION

3.01 Joints

- A. Bolts holes for flanged valves shall straddle the horizontal and vertical centerlines of the pipe run to which the valves are attached. Clean flanges by wire brushing before installing flanged valves. Clean flange bolts and nuts by wire brushing, lubricate threads with oil and graphite, and tighten nuts uniformly and progressively. If flanges leak under pressure testing, loosen or remove the nuts and bolts, reseal or replace the gasket, reinstall or

retighten the bolts and nuts, and retest the joints. Joints shall be watertight.

- B. Clean threaded joints by wire brushing or swabbing. Apply Teflon joint compound or Teflon tape to pipe threads before installing threaded valves. Joints shall be watertight.
- C. Install grooved-end couplings for valves in accordance with the coupling manufacturer's recommendations. Clean loose scale, rust, oil, grease, and dirt from the pipe and valve grooves before installing coupling. Apply the coupling manufacturer's gasket lubricant to the gasket exterior including lips, pipe ends, and housing interiors. Fasten coupling alternately and evenly until coupling halves are seated.

3.02 Installing Exposed Valves

- A. Unless otherwise indicated in the drawings, install valves in horizontal runs of pipe having centerline elevations 4'-6" or less above the floor with their operating stems vertical. Install valves in horizontal runs of pipe having centerline elevations between 4'-6" and 6'-9" above the floor with their operating stems horizontal.
- B. Install valves on vertical runs of pipe that are next to walls with their stems horizontal, away from the wall. Valves on horizontal runs of pipe that are not located next to walls shall be installed with their stems horizontal, oriented to facilitate valve operation.

3.03 Installing Buried Valves

- A. Connect the valve, coat the flanges, apply polyethylene encasement, and place and compact the backfill to the height of the valve stem.
- B. Place block pads under the extension pipe to maintain the valve box vertical during backfilling and repaving to prevent the extension pipe from contacting the valve bonnet.
- C. Mount the upper slip pipe of the extension in midpoint of the valve box and secure with backfill around the extension pipe as shown in Standard Drawing W-6. Pour the concrete ring allowing a depression so the valve box cap will be flush with the pavement surface.
- D. In open areas, install the valve box as for a paved area with concrete curb except include a marker post. Cut the marker post from 4 x 4" dense structural grade redwood or Southern Pine surfaced on four sides to a length of 5 feet. Chamfer the top. Set the post in concrete, 2 feet into the ground, away from traffic, and to the side of the pipeline. Coat with a seal and finish coat of white alkyd exterior paint. On the side facing the valve, letter in the black word "VALVE" and the distance in feet from the marker post to the valve box cap.

3.04 Field Coating Buried Lines

- A. Coat flanges of buried valves and the flanges of the adjacent piping, and the bolts and nuts of flanges and mechanical joints, per Section 09900, System No. 24.
- B. Wrap buried metal valves 6 inches and larger in two layers of polyethylene conforming to AWWA C105, 8 mils in thickness each. Pass the two sheets of polyethylene under the valve and coated flanges or joints with the connecting pipe and draw the sheet around the

valve body, valve bonnet, and the connecting pipe. Secure the sheets with plastic adhesive tape about the valve stem below the operating nut and about the barrel of the connecting pipe to prevent entrance of soil. Fold overlaps twice and tape. Backfill the valve with care avoid damaging the polyethylene.

3.05 Mounting Gear Actuators

- A. The valve manufacturer shall select and mount the gear actuator and accessories on each valve and stroke the valve from fully open to fully closed prior to shipment.

3.06 Field Installation of Gear Actuator

- A. Provide the actuator manufacturer's recommended lubricating oil in each actuator before commencing the field testing.

3.07 Valve Field Testing

- A. Test valves for leakage at the same time that the connecting pipelines are tested. See Section 15044 for pressure testing requirements. Protect or isolate any parts of valves, actuators, or control and instrumentation systems whose pressure rating is less than the pressure test. Valves shall show zero leakage. Repair or replace any leaking valves and retest.
- B. Operate manual valves through three full cycles of opening and closing. Valves shall operate from full open to full close without sticking or binding. Do not backfill buried valves until after verifying that valves operate from full open to full closed. If valves stick or bind, or do not operate from full open to full closed, repair or replace the valve and repeat the tests.
- C. Gear actuators shall operate valves from full open to full close through three cycles without binding or sticking. The pull required to operate handwheel- or chainwheel-operated valves shall not exceed 80 pounds. The torque required to operate valves having 2-inch AWWA nuts shall not exceed 150 ft-lbs. If actuators stick or bind or if pulling forces and torques exceed the values stated previously, repair or replace the actuators and repeat the tests. Operators shall be fully lubricated in accordance with the manufacturer's recommendations prior to operating.

END OF SECTION

SECTION 15108 AIR-RELEASE AND VACUUM-RELIEF VALVES

PART 1 - GENERAL

1.01 Description

- A. This section includes materials and installation of air and vacuum valves, air-release valves, combination air-release valves, slow-closing air and vacuum valves, and slow-closing combination air-release valves for water service.
- B. Related Work Specified Elsewhere
 - 1. Fusion-Bonded Epoxy Linings and Coatings: 09811
 - 2. Painting and Coating: 09900
 - 3. Pressure Testing of Piping: 15044
 - 4. Manual, Check, and Process Valves: 15100
 - 5. Standard Drawings

1.02 Submittals

- A. Submit shop drawings in accordance with the General Conditions.
- B. Submit manufacturer's catalog data, detail drawings showing all valve parts and described by material of construction, specification (such as AISI, ASTM, SAE, or CDA), and grade or type. Show linings and coatings.

PART 2 - MATERIALS

2.01 Bolts and Nuts for Flanged Valves

- A. See specification for the pipe to which the valve is attached.

2.02 Gaskets for Flanged End Valves

- A. Gaskets for flanged end valves shall be as described in the detail piping specifications.

2.03 Valve Design and Operation

- A. Valve shall comply with AWWA C512, except as modified herein. Class 150 valves shall have a maximum working pressure of at least 150 psi. Class 300 valves shall have a maximum working pressure of at least 300 psi. Class 500 valves shall have a maximum working pressure of at least 500 psi.

- B. Air-release release valves shall include a float assembly and large venting orifice to exhaust large quantities of air from pipelines when being filled and to admit large quantities of air when pipelines are being drained. Valves shall have a body with a flanged or threaded top containing the air release orifice. The float shall rise with the water level in the valve body to close the orifice by sealing against a synthetic rubber seat. The float shall withstand an external pressure of 1,000 psig without collapsing.
- C. 1-inch and 2-inch valves shall include a 3/8-inch threaded outlet with stainless steel base. 3-inch and 4-inch valves shall include a 1-inch threaded outlet with stainless steel base.

2.04 Materials of Construction

- A. Materials of construction for air and vacuum valves for water service shall be as follows:

Item	Material	Specification
Body and cover	High strength composite materials	—
Float, lever or linkage, air-release mechanism	Foamed polypropylene	AISI Type 316, ASTM A240 or A276
Base and trim	Stainless Steel	—
Rolling seal, seat	EPDM	

Valves shall be A.R.I D-040-ST, 1-inch or 2-inch, or A.R.I D-060-C, 3-inch and 4-inch.

2.05 Seating

- A. Valves shall seat drip tight at a pressure of 1 psi.

2.06 Valve End Connections

- A. Valves smaller than 2 inches shall have threaded ends at the bottom of the body. 3-inch and 4-inch valves shall have flanged ends.
- B. Flanges for Class 150 valves shall comply with ANSI B16.1, Class 125. Flanges for Class 300 valves shall comply with ANSI B16.1, Class 250.
- C. Threaded ends shall comply with ANSI B1.20.1.

2.07 Valves

- A. Air and Vacuum Valves, 3 Inches and Smaller:
 - 1. Valves shall have an operating pressure of 300 psi. Provide steel hood above the top cover and orifice. Valves shall be A.R.I D-040 1-inch or 2-inch.

PART 3 - EXECUTION

3.01 Factory Test

- A. Test each valve per AWWA C512, Section 5 and the following.
- B. Hydrostatically test the pressure-containing parts at the factory with water for 30 minutes minimum at a pressure of 1.5 times the rated pressure but not less than 20 psig. Test shall show zero leakage. If leaks are observed, repair the valve and retest. If dismantling is necessary to correct valve deficiencies, provide an additional operational test per AWWA C512, Section 5 for each affected valve.
- C. The chloride content of liquids used to test austenitic stainless steel materials shall not exceed 50 ppm. To prevent deposition of chlorides as a result of evaporative drying, remove residual liquid from tested parts at the conclusion of the test.

3.02 Painting and Coating

- A. Coat valves in accordance with Section 09900, System No. 15. Apply the specified prime coat at the place of manufacture. Apply finish coats in the field. Finish coat shall be as selected by the District.
- B. Coat interior surfaces of cast-iron valves at the place of manufacture per Section 09900, System No. 7. Do not coat seating areas and plastic, bronze, stainless steel, or other high alloy parts.
- C. Alternatively, line and coat cast-iron valves with fusion-bonded epoxy per Section 09811. Do not coat seating areas and plastic, bronze, stainless-steel, or other high alloy parts.

3.03 Installation

- A. Clean flanges by wire brushing before installing flanged valves. Clean flange bolts and nuts by wire brushing, lubricate threads with oil and graphite, and tighten nuts uniformly and progressively. If flanges leak under pressure testing, loosen or remove the nuts and bolts, reseal or replace the gasket, reinstall or retighten the bolts and nuts, and retest the joints. Joints shall be watertight.
- B. Clean threaded joints by wire brushing or swabbing. Apply Teflon joint compound or Teflon tape to pipe threads before installing threaded valves. Joints shall be watertight.
- C. Do not use duct tape and plastic for covering the ends of pipe flanges. Use a solid metal cover with rubber gasket to cover flange openings during installation. These metal covers shall remain in place until the piping is connected to the valves.
- D. Do not spring flanges of connecting piping into position. Separately work connecting piping systems into position to bring the piping flanges into alignment with the matching valve flanges. Do not move valves to achieve piping alignment. Do not use electrical

heating stress relieving to achieve piping alignment.

- E. Line up pipe flange bolt holes with valve nozzle bolt holes within 1/16 inch maximum offset from the center of the bolt hole to permit insertion of bolts without applying any external force to the piping.
- F. Flange face separation shall be within the gasket spacing $\pm 1/16$ inch. Use only one gasket per flanged connection.

3.04 Valve Pressure Testing

- D. Test valves at the same time that the connecting pipelines are pressure tested. See Section 15044 for pressure testing requirements. Protect or isolate any parts of valves, operators, or control and instrumentation systems whose pressure rating is less than the test pressure.

END OF SECTION

SECTION 15109 FIRE HYDRANTS

PART 1 – GENERAL

1.01 Description

- A. This section includes materials, testing, and installation of wet barrel fire hydrants.

1.02 Related Work Specified Elsewhere

- A. Trenching, Backfilling, and Compacting: 02223.
- B. Painting and Coating: 09900.
- C. Manual, Check, and Process Valves: 15100.
- D. Standard Drawings.

1.03 Submittals

- A. Submit shop drawings in accordance with the General Conditions.
- B. Submit certificate of compliance with AWWA C502 and C503.
- C. Submit manufacturer's catalog data and descriptive literature. Submit dimensional drawings. Show coatings.

PART 2 - MATERIALS

2.01 Fire Hydrant Selection

- A. In general, provide fire hydrants of the wet barrel design. In those areas, such as hillsides where a broken hydrant might cause some serious erosion damage, provide hydrant check valve.
- B. Wet Barrel Fire Hydrant Design
 - 1. Fire hydrants shall comply with AWWA C503. Provide hydrant head, barrel and bury section. Barrel connecting flange shall be drilled to the dimensions of ANSI B16.1, Class 125, 6-inch size, flat face.
 - 2. Head and barrel shall be bronze per AWWA C503.

3. Provide one 2-1/2-inch and one 4-inch nozzles. Threads on nozzles shall conform to ANSI B26. Provide cap with chain on each nozzle.
 4. Bury section shall be ductile iron per Section 15056.
 5. Inlet Connection of Bury: Mechanical joint or ductile iron push-on with rubber gaskets.
 6. Provide a double-grooved break-off riser and 6 hole break off check valve, CLOW LP619, as required by the District. The valve flapper shall be bronze and be housed in a recess out of the waterway.
 7. Manufacturer's and Models: Jones 4040 AR or CLOW 850
- C. Bolts and Nuts for Flanges (Wet Barrel Hydrants)
1. Bolts and nuts connecting the top section to the bury section shall be Type 316 stainless steel conforming to ASTM A 193 (Grade B8M) for bolts and ASTM A 194 (Grade 8M) for nuts. Provide washer for each nut. Washers shall be of the same material as the nuts.

PART 3 – EXECUTION

3.01 Painting and Coating

- A. Coat hydrant top section and the exposed portion of the bury section per Section 09900, System No. 15. Apply prime coat at factory. Color of finish coat shall be chrome yellow. Apply finish coat in field.
- B. Coat buried ductile iron per Section 15056.

3.02 Factory Testing

- A. Test per AWWA C502 and C503, Section 5.

3.03 Installation

- A. Install with the face of the bottom flange of the barrel 4 to 6 inches above the adjacent ground or paving.
- B. In general, install hydrants so that the distance from the curb face to a hydrant outlet is no less than 18 inches and no greater than 6 feet. Conform to local ordinances governing parkway obstructions, if any.
- C. Provide thrust block on bury elbow as detailed in the drawings.

END OF SECTION

DRAFT

SECTION 15112 BACKFLOW PREVENTERS

PART 1 - GENERAL

1.01 Description

- A. This section includes materials and installation of detector checks.

1.02 Related Work Specified Elsewhere

- A. Painting and Coating: 09900
- B. Pressure Testing of Piping: 15044
- C. Manual, Check, and Process Valves: 15100

1.03 Submittals

- A. Submit shop drawings in accordance with the General Conditions.
- B. Submit manufacturer's catalog data and descriptive literature. Submit dimensional drawings. Call out materials of construction by ASTM reference and grade. Show coatings.

PART 2 - MATERIALS

2.01 Backflow Preventors

- A. Backflow preventers shall be of the reduced pressure type, complying with AWWA C511. Provide two independently operating check valves, two shutoff valves, an automatic pressure differential relief valve, and test cocks so that a test of each check valve can be made.
- B. Backflow preventers of sizes 2 inches and smaller shall have bronze (ASTM B61 or B62) check valves. Check valves shall be of the poppet type and have replaceable seats.
- C. Backflow preventers 2 inches and larger shall have check valves of either the poppet or the toggle lever type. Check valves larger than 2 inches shall have cast-iron (ASTM A126, Class B) body and cover.
- D. Differential relief valve shall be bronze (ASTM B61 or B62) with Type 304 or 316 stainless steel trim.

PART 3 - EXECUTION

3.01 Painting and Coating

- A. Coat detector checks including isolation valves the same as the adjacent piping. If the adjacent piping is not coated, then coat per Section 09900, System No.12. Apply the specified prime coat at the place of manufacture. Apply intermediate and finish coats in field. Do not coat bronze or stainless steel items. Finish coat shall be OSHA Safety Red.
- B. Line detector checks 4 inches and larger (including isolation valves) on the interior metal parts, excluding seating areas and bronze and stainless-steel pieces per Section 09900, System No. 7.

3.02 Field Testing

- A. Pressure test the detector checks along with the connecting piping per Section 15044. There shall be no visible leaks in the detector check assembly, valves, or joints of the interconnecting piping.

END OF SECTION

SECTION 15122 FLEXIBLE PIPE COUPLINGS

PART 1 - GENERAL

1.01 DESCRIPTION

- A. This section includes materials and installation of flexible gasketed sleeve-type compression pipe couplings for steel and ductile iron pipe, and couplings for connecting different pipe materials.

1.02 RELATED WORK SPECIFIED ELSEWHERE

- A. Fusion-Bonded Epoxy Linings and Coatings: 09811
- B. Painting And Coating: 09900
- C. Piping Schedule and General Piping Requirements: 15000
- D. Pressure Testing of Piping: 15044
- E. Cathodic Protection and Join Bonding: 1664

1.03 SUBMITTALS

- A. Submit shop drawings in accordance with the General Conditions.
- B. Submit manufacturer's catalog data on flexible pipe couplings. Show manufacturer's model or figure number for each type of coupling or joint for each type of pipe material for which couplings are used. Show coatings.
- C. Submit manufacturer's recommended torques to which the coupling bolts shall be tightened for the flexible gasketed sleeve-type compression pipe couplings.
- D. Show materials of construction by ASTM reference and grade. Show dimensions.
- E. Show number, size, and material of construction of tie rods and lugs for each thrust harness on the project.

PART 2 - MATERIALS

2.01 COUPLING SYSTEM DESIGN AND COMPONENT UNIT RESPONSIBILITY

The coupling manufacturer shall furnish the gaskets, bolts, nuts, glands, end rings, and hardware for pipe couplings of all types and shall design these components as an integral system. Design the gaskets for the coupling and appropriately size to provide a watertight seal at the design pressure and temperature. Ship gaskets, bolts, nuts, glands, end rings, and hardware for pipe couplings with the pipe coupling and clearly label indicating the origin of the material, including place and date of manufacture. Package the manufacturer's printed installation instructions with each pipe coupling.

2.02 STEEL FLEXIBLE PIPE COUPLINGS

- A. Steel couplings shall have middle rings made of steel conforming to ASTM A 36, A 53 (Type E or S), or A 512 having a minimum yield strength of 30,000 psi. Follower rings shall be malleable iron (ASTM A 47, Grade 32510), ductile iron (ASTM A 536), or steel (ASTM A 108, Grade 1018, or ASTM A 510, Grades 1018 or 1021). Minimum middle ring length shall be 5 inches for pipe sizes 3/4 inch through 4-1/2 inches; 7 inches for pipe sizes 5 inches through 24 inches; and 10 inches for pipe sizes larger than 24 inches.
- B. Sleeve bolts shall have a minimum yield strength of 40,000 psi, a tensile strength of 60,000 psi, and shall conform to AWWA C 111, Appendix B.
- C. Steel follower rings shall be cast, forged, or hot rolled in one piece. Do not use rings fabricated from two or more shapes.
- D. Wall thickness of sleeve shall be at least that specified for the size of pipe in which the coupling is to be used.

2.03 CAST-IRON FLEXIBLE PIPE COUPLINGS

- A. Cast-iron couplings shall have sleeves made of gray iron conforming to ASTM A 126, Class B, cast iron, conforming to ASTM A 48, Class 30 (minimum), or ductile iron conforming to ASTM A 536. Followers shall be made of malleable iron (ASTM A 47, Grade 32510) or ductile iron (ASTM A 536).
- B. Sleeve bolts shall have a minimum yield strength of 40,000 psi, tensile strength of 60,000 psi, and shall conform to AWWA C111, Appendix B.

2.04 FLEXIBLE PIPE COUPLINGS FOR PLAIN-END STEEL PIPE

- A. Couplings shall be steel, Dresser Style 38, Smith-Blair Type 411, Baker Series 200, or equal.

2.05 FLEXIBLE PIPE COUPLINGS FOR PLAIN-END DUCTILE-IRON PIPE

- A. Couplings for pipe 12 inches and smaller shall be cast iron, Dresser Style 153, Smith-Blair Type 441, Baker Series 228, or equal.
- B. Couplings for pipe larger than 12 inches shall be cast iron or steel, Dresser Style 38 or 153, Smith-Blair Style 411, Baker Series 228, or equal.

2.06 TRANSITION COUPLINGS

- A. Couplings for connecting different pipes having different outside diameters shall be steel: Dresser Style 62 or 162, Smith-Blair Series 413, Baker Series 212 or 220, or equal.

2.07 FLANGED COUPLING ADAPTERS FOR STEEL PIPE

- A. Adapters for steel pipe shall be steel: Dresser Style 128, Smith-Blair Type 913, or equal.

Flange ends shall match the flange of the connecting pipe; see detail piping specifications.

2.08 FLANGED COUPLING ADAPTERS FOR CAST- AND DUCTILE- IRON PIPE

- A. Adapters for cast-and ductile-iron pipe 12 inches and smaller shall be cast iron: Dresser Style 127, Smith-Blair Series 912, or equal.
- B. Adapters for cast-and ductile-iron pipe larger than 12 inches shall be steel: Dresser Style 128, Smith-Blair Type 913, or equal.
- C. Flange ends shall match the flange of the connecting pipe; see piping specifications.

2.09 BOLTS AND NUTS FOR FLANGES

- A. See Section 15000.

PART 3 - EXECUTION

3.01 SHIPMENT AND STORAGE OF FLEXIBLE PIPE COUPLINGS, DISMANTLING JOINTS, EXPANSION JOINTS, AND FLEXIBLE HOSE CONNECTORS

- A. Inspect on receipt for damage in shipment and conformance with quantity and description on the shipping notice and order. Unload carefully to the ground without dropping. Do not load or unload by inserting forklift tines or lifting chains inside the waterway. Use nonmetallic slings, padded chains, or padded forklift tines to lift items. Lift with eyebolts or rods through flange holes or chain hooks at ends.
- B. Protect from weather and the accumulation of dirt, rocks, and debris. Do not expose rubber seats to sunlight or ozone for more than 30 days. Also, see the manufacturer's specific storage instructions.
- C. Make sure flange faces, joint sealing surfaces, body seats, and disc seats are clean.

3.02 INSTALLATION OF FLEXIBLE PIPE COUPLINGS AND EXPANSION JOINTS

- A. Clean oil, scale, rust, and dirt from pipe ends. Clean gaskets in flexible pipe couplings before installing.
- B. Install expansion joints per manufacture's recommendations, so that 50% of total travel is available for expansion and 50% is available for contraction.
- C. Lubricate bolt threads with graphite and oil prior to installation.

3.03 PAINTING AND COATING

- A. Coat buried flexible pipe couplings and flanged coupling adapters per Section 09900, System No. 24. Coat buried bolt threads, tie bolt threads, and nuts per Section 09900, System No. 24. Then wrap the couplings with polyethylene wrap per Section 15056.

- B. Coat flexible pipe couplings and flanged coupling adapters located indoors, in vaults and structures, and above ground with the same coating system as specified for the adjacent pipe. Apply prime coat at factory.
- C. Line flexible pipe couplings with epoxy per Section 09900, System No. 7.
- D. Alternatively, line and coat flexible pipe couplings with fusion-bonded epoxy per Section 09811.

3.04 BONDING FLEXIBLE PIPE COUPLINGS

- A. Bond buried flexible pipe couplings that are connected to ductile-iron, cast-iron, or steel pipe as described in Section 16640.

3.05 HYDROSTATIC TESTING

- A. Hydrostatically test flexible pipe couplings, expansion joints, and expansion compensators in place with the pipe being tested. Test in accordance with Section 15044.

END OF SECTION

DRAFT

SECTION 15123 CORPORATION STOPS AND SERVICE SADDLES

PART 1 - GENERAL

1.01 DESCRIPTION

- A. This section includes materials and installation of service saddles and corporation stops.

1.02 RELATED WORK SPECIFIED ELSEWHERE

- A. Painting and Coating: 09900
- B. Pressure Testing of Piping: 15044

1.03 SUBMITTALS

- A. Submit shop drawings in accordance with the General Conditions.
- B. Submit manufacturer's catalog data and descriptive literature showing dimensions and materials of construction by ASTM reference and grade. Show coatings.

PART 2 - MATERIALS

2.01 CORPORATION STOPS

- A. Corporation stops shall be manufactured brass. The inlet fitting shall be a male iron pipe thread when used with saddle and the outlet connection shall be a compression type or iron- pipe thread. Corporation stops shall be "ball style" as manufactured by A.Y. McDonald, Cambridge Brass, Ford Meter Box, Jones, or Mueller.

2.02 SERVICE SADDLES FOR DUCTILE-IRON, STEEL, AND PVC (AWWA C900) PIPE

- A. Service saddles shall be of the double-strap type. Straps and bodies shall be bronze or silicon bronze. Tap sizes on the outlet shall be 3/4 inch through 2 inches to accommodate the connecting piping or corporation stops, Service saddles shall be James Jones J-979 (for ductile-iron and steel pipe), James Jones J-996 (for PVC pipe), Mueller, or equal. See District Standard Drawings W-1 and W-2.

PART 3 - EXECUTION

3.01 INSTALLATION OF SERVICE SADDLES

- A. Install service saddles with the gaskets seated on the pipe so that zero leakage is obtained. Tighten bolts to the torque recommended by the manufacturer.

3.02 INSTALLATION OF CORPORATION STOPS

- A. Use a smooth-jawed adjustable wrench that fully and evenly engages the corporation stop wrenching flats. Place the wrench only on the stop body wrench flats. Do not use the

rounded areas of the stop body for tightening into the main or saddle. When connecting the outlet service line, use two wrenches to make the connection. Use one wrench to support the corporation stop and/or curb stop and the other wrench to tighten the service connection.

- B. Backfill and compact soil carefully around the corporation stop, curb stop, and service line to prevent ground settling and damage to the valve or service line.

3.03 FIELD PRESSURE TESTING OF CORPORATION STOPS AND SERVICE SADDLES

- A. Perform service line pressure testing prior to backfilling of buried service saddles and corporation stops.
- B. External leakage through the corporation stop body is not allowed. During testing of ground key stops, the outlet may be capped to eliminate leakage through the stop's closed port opening. Test pressures shall not exceed 150% of the maximum working pressure specified in AWWA C800. Cap stop outlets and test in the open position. When testing a water main, if capping the corporation stop is impractical, test to the curb stop with the corporation stop in the open position.
- C. Test pressures on service saddles for attachment to plastic pipe should be limited to 150% of the lower-rated component.

3.04 PAINTING AND COATING OF SERVICE SADDLES

- A. Coat buried service saddles per Section 09900, System No, 21.
- B. Coat service saddles located above ground or in vaults and structures per Section 09900, System No, 21.

END OF SECTION

SECTION 16640 CATHODIC PROTECTION AND JOINT BONDINGS

PART 1 - GENERAL

1.01 DESCRIPTION

- A. This section includes materials, testing, and installation of cathodic protection and testing equipment including wiring, zinc anodes, joint bonding, test stations, reference cells, alumino-thermic welds, and flange insulations kits.

1.02 RELATED WORK SPECIFIED ELSEWHERE

- A. Trenching, Backfilling, and Compacting: 02223
- B. Painting And Coating: 09900
- C. Standard Drawings

1.03 SUBMITTALS

- A. Submit shop drawings in accordance with the General Conditions.
- B. Submit manufacturer's catalog data on anodes, wire and cables, anode backfill material, test stations, reference cells, and thermite welds.

1.04 MANUFACTURERS

- A. Anodes, wire, and anode backfill material shall be systems as designed by Corpro; Northtown; Farwest Corrosion Control, Matcor, Inc.; or equal.

PART 2 - MATERIALS

2.01 Alumino-Thermic Weld Materials

- A. Cartridges and sleeves for welding test lead wires, joint bonding wires and anode lead wires to the pipe, shall be "Cadweld," or "Thermoweld." Based on the type of pipe (steel, ductile iron, or cast iron) to which the wire is to be welded, the cartridge type, size and weight shall be as recommended by the manufacturer.

2.02 Alumino-Thermic Weld Caps

- A. Alumino-thermic weld caps shall incorporate a high-density polyethylene plastic sheet that has minimum thickness of 10 mils with a 165 mils thick protective adhesive as manufactured by Farwest Corrosion Control Company or Chase Corporation's Royston Products.
- B. Design shall incorporate an elastomeric or a mastic-filled dome and a tunnel portion to contain lead wire from the alumino-thermic weld connection. The mastic coating shall be Royston Products, Tnemec 46-465, or Tnemec 46H-413. Prior to application of the mastic

coating, the manufacturer's recommended primer shall be applied to exposed metal.

2.03 Coating Selection

Alumino-thermic connection coating shall be in accordance with the following.

<u>Pipe Material</u>	<u>Connection Coating</u>
Cement-mortar coated steel plastic weld cap shall not be used.	Carboline Carboguard 890 VOC and mortar. A
Carbon steel, Ductile iron Cap XL IP or Royston Handy Cap IP.	Thermic weld cap with mastic, Royston Handy

2.04 Test Station Boxes

- A. Test station boxes shall be a minimum 10-inch diameter, 12-inch deep, precast concrete with a cast iron lid designed for H-20 traffic loading. "CPTS" shall be cast on the lid. Test boxes shall be Brooks Products 3-RT, or Eisel Enterprises. Test boxes with terminal boards for anodes shall be rectangular in accordance with Section 03462, Precast Concrete Vaults and Meter Boxes. Test box lids shall be painted in accordance with Section 09900, Painting and Coating.

2.05 Pipe Leads

- A. Unless noted otherwise, pipe leads shall be stranded copper wire with high molecular weight polyethylene (HMW/PE) insulation specifically designed for cathodic protection service and suitable for direct burial in corrosive soil or water. Wire gauge shall be as shown on District Standard Drawing W-16. Polyethylene insulation shall conform to ASTM D1248, Type I, Class C, Grades E-4 and E-5. Each pipe lead shall be of sufficient length to extend from the attachment to the pipe to the test box or anode test box without a splice. Wires with cut or damaged insulation shall be rejected. Insulation color shall be as shown on the plans or District Standard Drawings.

2.06 Joint Bonding Wires

- A. Pipe joint bonding wires shall be AWG No. 4 stranded copper wire with minimum 7/64-inch thick high molecular weight polyethylene (HMW/PE) insulation rated for 600 volts. The number of conductors shall be as shown on the plans and/or District Standard Drawings. Polyethylene insulation shall conform to ASTM D1248, Type I, Class C, Grade 5. Each bond wire shall be 18 inches in length for 18-inch pipes or less and 24 inches for pipes larger than 18-inch.

2.07 Flange Insulation Kits

Insulating material shall be of the type designated by the manufacturer as suitable for the operating temperature and pressure of the service. Flange insulation kits shall consist of:

- A. Insulating Gaskets: Gaskets shall be Type E full-faced, 1/8-inch minimum thickness, dielectric neoprene faced phenolic. Gaskets shall be Advance Products & Systems, Inc. (APS), George Fischer Central Plastics, or Pipeline Seal & Insulator, Inc. (PSI).
- B. Insulating Sleeves and Washers: Insulating stud sleeves and washers shall be one-piece and full-length, made of Minlon or Mylar. One 1/8-inch thick gasket shall be attached to the sleeve, while the other shall be loose.
- C. Single insulating washers and sleeves shall be used on buried insulating flanges. Double insulating valves shall be used on insulating flanges above ground, in structures, or in vaults.
- D. Insulating Washers for Bolts: Insulating washers shall be 1/8-inch thick glass- clad phenolic. Single insulating washers shall be used on buried insulating flanges. Double insulating washers and full length sleeves shall be used on insulating flanges above ground, in structures, or in vaults.
- E. Steel Washers Over Insulating Washer: Steel backing washers shall be 1/8-inch thick Type 316 stainless steel.
- F. Compatibility with Valves: Insulating flange kits are not compatible with most valve flanges. Where cathodic isolation is required near a valve, a flanged spool shall be installed adjacent to the valve; and the required insulating joint shall be installed at the opposite end of the spool from the valve. Refer to the project plans for specific details.
- G. Manufacturers: Flange insulation kits shall be as manufactured by Advance Products & Systems, Inc. (APS), George Fischer Central Plastics, or Pipeline Seal & Insulator, Inc. (PSI).

2.08 Buried Insulating Flange External Coating

- A. Primer: Primer shall be a blend of microcrystalline waxes, plasticizers and corrosion inhibitors having a paste-like consistency. The material shall have the following properties:

Pour Point	100°F -115°F
Flash Point	350°F min
Coverage (approx.)	1 gallon/100 sq. ft.
Color	Brown

The primer shall be Trenton Wax-Tape Primer.

- B. Wax-Tape: Flange covering material shall be a plastic-fiber felt tape, saturated with a blend of microcrystalline waxes, plasticizers and corrosion inhibitors that is easily formable over irregular surfaces. The tape shall have the following properties:

Tape Width	6-inches
Saturant Pour Point	115°F - 125°F
Thickness	70 - 90 mils
Dielectric Strength	170 Volts/mil
Weight	4 lbs/sq yd
Color	Brown

The Wax-Tape shall be Trenton #1 Wax-Tape.

- C. Outer Covering: The primed and wax-tape wrapped flange shall be covered with a plastic wrapper consisting of three each of 50 gauge, clear, polyvinylidene chloride, high cling membranes wound together as a single sheet. The material shall have the following properties:

Width	6-inches
Thickness	1 1/2 mils
Dielectric Strength	2000 Volts/mil
Water Absorption	Negligible
Color	Clear

The outer covering shall be Trenton Poly-Ply.

2.09 Internal Insulating Flange Coating

- A. Coating for the interior lining of the pipeline at the insulating flange shall be a two-part smooth white, thixotropic liquid epoxy consisting of 100 percent solids. Coating shall be Aquatapoxy Paint as manufactured by American Chemical Corporation.

2.10 Zinc Anodes

- A. Zinc Anode: Anode shall conform to ASTM B418, Type II and shall be a prepackaged zinc alloy ingot having a chemical composition not exceeding the following limits:

Lead	0.003% Max.
Aluminum	0.005% Max.
Cadmium	0.003% Max.
Iron	0.0014% Max.
Copper	0.002% Max.
Zinc	Remainder

- B. Anode Weight and Dimensions: Ingot weight and dimensions of the pre- packaged zinc anode shall be as listed in the table below. Weights are minimum.

<u>ZINC ANODE SIZES FOR 1-1/2 - INCH & 2-INCH COPPER SERVICES</u>				
Copper (feet)	Pipe Length	Anode Size (inches)		Anode Weight (lbs.)
	0 – 45	1.4 x 1.4 x 30		15
	45 – 90	2.0 x 2.0 x 30		30

- C. Anode Backfill: Each zinc anode shall either be prepackaged in a permeable cloth bag with backfill of the following composition or installed bare and backfilled with material having the following composition:

Gypsum	75%
Powdered Bentonite	20%
Anhydrous Sodium Sulfate	5%

Backfill grains shall be capable of 100% passing through a 20 mesh screen and 50% passing through a 100 mesh screen.

The backfill shall be firmly packed around the anode by mechanical vibration, which will maintain the zinc ingot in the center of the cloth bag and surrounded by at least 1-inch of backfill. The packaged weight of the zinc anode and backfill shall be approximately twice the weight of the zinc anode ingot weight.

- D. Steel Core: Anode shall be cast full length with an electro-galvanized 1/4-inch diameter steel core, which shall be exposed at one end for connection of the anode lead wire.
- E. Anode Lead Wire: Anode lead wire shall be AWG No. 8 stranded copper wire with high-molecular weight polyethylene (HMW/PE) insulation suitable for direct burial use. HMW/PE insulation shall conform to ASTM D1248, Type 1, Class "C", Category 5, Grades E4 and E5 with tensile strengths J1, J3.

Wire shall be attached to the steel core with silver solder by the anode manufacturer. The connection shall be encapsulated in a heat-shrinkable sleeve. Anode lead wire shall be a minimum of 15 feet long and shall be of sufficient length to extend from the anode to the designated termination point without a splice and 3-feet of coiled wire shall be provided in the test box. Wires with cut or damaged insulation shall be rejected and replacement of the entire lead shall be required at the Contractor's expense.

- F. Anode Manufacturer's: Pre-packaged anodes with lead wire and bagged backfill shall be supplied by Northtown Company, Far West Corrosion Control Company, or Galvotech Alloys, Inc.

2.11 Mortar

- A. Mortar used to repair concrete coated pipe after attachment of the various bond or test wires shall be fast drying, non-shrinkable type. Refer to Section 03000, Concrete.

2.12 Marker Paddles – Utility Marker

- A. Brown colored polycarbonate marker paddles shall be installed adjacent to the location of each test station, anode bed, shunt box, and reference cell location. Marker paddles

shall be as manufactured by Carsonite Composites, a Phillips Group Brand. Marker paddles shall have an District logo and 1-inch high yellow letters affixed, indicating the particular cathodic appurtenance. Refer to the District Standard Drawing W-19.

2.13 Pipe Clamps

- A. Pipe clamps used to attach the zinc anode lead wire to the above ground copper riser portion of the copper water tubing shall be brass or copper and of a size to fit the tubing. The pipe clamp shall have a screw terminal suitable for an AWG No. 8 copper stranded wire.

2.14 Insulating Blanket

- A. The insulating blanket shall be a 1/8-inch thick neoprene or butyl insulating material. The width and length of the blanket will vary due to diameter of the pipelines to be insulated. The width and length shall be 12-inches larger than the diameter of the largest pipeline to be insulated.

2.15 Casing Seal

- A. The casing seal shall be composed of an irradiated, semi-rigid polyolefin sleeve which when exposed to temperatures in excess of 250°F will shrink from its original diameter to a predetermined recovered diameter. Casing seal shall be as manufactured by Advance Products & Systems, Inc. (APS) or Pipeline Seal & Insulator, Inc. (PSI).

2.16 Reference Electrodes

- A. Reference electrodes shall be copper-copper sulfate type, suitable for direct burial, and shall remain stable for at least ten years. The reference cell shall be capable of maintaining a potential within 15 millivolts of a freshly made cell while drawing 2 microamperes. Reference cells shall contain a barrier to inhibit migration of chloride ions from the soil into the reference cell.

PART 3 - EXECUTION

3.01 General

- A. Cathodic protection installation shall conform to NACE Publication RP0169 (Latest Revision) – "Recommended Practice, Control of External Corrosion on Underground and Submerged Metallic Piping Systems" and to NACE Publication RP0286 (Latest Revision) – "Recommended Practice, Electrical Insulation of Cathodically Protected Pipelines".

3.02 Wire Attachments

- A. Wire leads shall be attached to the pipe and shall terminate at the test box without a splice. A minimum of 3-feet of slack wire from each lead shall be coiled and remain in each test box.

3.03 Attachment of Wire to Pipe

- A. Surface Preparation for Alumino-Thermic Welding: Any existing coating on the pipe shall be removed by making a 3-inch square window in the coating. The exposed metal surface shall be cleaned to produce a bright metal finish, equivalent to SSPC SP-10, "near-white".
- B. Alumino-Thermic Weld: The attachment of copper wire shall be made using an alumino-thermic weld as shown on District Standard Drawing W-15. Remove only enough insulation from the wire to allow the weld connection to be made. The wire shall be held at a 30°- 45° angle to the surface when welding. One wire only shall be attached to each weld.
- C. Weld Test: As soon as the weld is cool, the weld shall be tested by striking a sharp blow with a 3-pound hammer while pulling firmly on the wire. All unsound welds shall be rewelded and retested.
- D. Wire Locations: Wires shall be attached to the top (horizontal) surface of the pipe. Where two or more wires are required, welds shall be at least 6-inches apart.
- E. Alternative Attachment Methods: The weld mold may not fit between the pretension bars of concrete cylinder pipe, depending on the diameter and pressure class of the pipe. Alternate methods of attachment may include: thermite welding the test wire to the bell ring at a joint; or arc welding a 1/4-inch diameter steel bar, with test wire pre-attached, to the steel cylinder between pretension bars.

3.04 Dielectric Coating Over Thermic Weld Connection

- A. After completing the thermic weld connection between the wire and the pipe, the connection shall be coated. Repairs to the cement mortar coating shall be of the same material and thickness as specified for the pipe.

3.05 Backfill Over Wire

- A. Buried wires shall be installed at a minimum depth of cover of 36-inches below the street section, or 36-inches below finished grade for un-paved areas. The trench bottom shall be level and free of exposed rocks. The first 12-inches of backfill above and the first 12-inches below the cable shall be sand per District bedding requirements. The remainder of the trench zone shall be backfilled in accordance with Section 02223, Trenching, Backfilling and Compaction. Plastic ID tape shall be installed 12-inches above the wire.

3.06 Test Stations

- A. Test Station Boxes: Test boxes shall be positioned in the parkway or raised median, as close to above the pipeline as practical. Boxes shall be installed in accordance with the District Standard Drawings.
- B. Two-Wire Test Station Spacing: Two-wire test stations with boxes shall be placed at

intervals not to exceed 500 feet and at the end-points of all metallic pipelines and casings.

3.07 Joint Bonding Wires

- A. Joint bonding wires shall be installed on ferrous metal pipelines at all unwelded joints, fittings, valves, and flanges (excluding insulated flanges) as shown on the District Standard Drawing W-15. Two bond wires shall be welded across each joint for pipe diameters less than 18-inches. Three bond wires shall be welded across joint for pipe diameters 18-inches and larger. Bond wires shall be attached using the alumino-thermic weld process. Bond wires shall not be attached to valve bodies, but instead to the valve flanges.

3.08 Flange Insulation Kits

Flange insulation kits shall be installed as follows:

- A. **Cleaning:** Faces of flange pairs shall be cleaned of all dirt, rust or fouling materials which would interfere with a watertight joint and insulating properties of the flange kit.
- B. **Alignment:** Alignment pins shall be used to properly align the flange and gasket. The manufacturer's recommended bolt tightening sequence shall be followed. Bolt insulation sleeves shall be centered within the insulation washers so that the insulating sleeve is not compressed and damaged.
- C. **Locations:** A bonding test station shall be installed at each buried flange insulation. Two test wires shall be installed on each side of the buried insulator according to the details of the plans, these specifications, and District Standard Drawings.
- D. **Insulation Kits at Valves:** Flange insulation kits shall not be installed directly against valve flanges. A 24-inch long spool shall be installed adjacent to the valve so that the insulating flange kit may be installed on a standard pair of flanges.

3.09 External Insulating Flange Coating

- A. **Buried Insulating Flange Coating:**

Primer: Surface shall be cleaned of all dirt, dust, and loose rust or mill scale by wire brush and by wiping with a clean cloth. The surface shall be dry. Apply primer by hand or brush. A thick coating of primer shall be worked into all crevices, around bolts and in threads, and shall completely cover all exposed metal surfaces. The primer should overlap the pipe coating by 3-inches minimum.

Wax-Tape: The wax-tape can be applied immediately after primer application. Short lengths of tape shall be cut and formed completely around each individual bolt and stud-end. After all bolts are covered, the tape shall be applied circumferentially and formed by hand into all voids and spaces. There shall be no gaps or air spaces under the tape. The tape shall be applied with at least 55% overlap.

Outer Covering: The clear plastic outer covering shall be applied by hand such that the material conforms and adheres to the wax-tape surface. Two layers of plastic outer wrapping shall be applied.

- B. Above Ground Insulating Flange Tape Coating: All flange and pipe surfaces shall be clean and free of all dirt, grease, water, and other foreign material prior to installation of tape coating. The two separate tapes shall be half-lapped twice over the outer surface of the flange.

3.10 Internal Coating at Insulating Flange

The interior of the pipeline shall be coated for a distance of two pipe diameters in each direction away from the insulating flange. At an insulated valve flange, interior of pipeline shall be coated away from the valve for a distance of two pipe diameters. Coating shall be in accordance with Section 09900, Painting and Coating, System No. B-1 or B-2 as appropriate.

- A. Surface Preparation: The surface preparation of the mortar lining shall consist of wire brushing to remove all loose mortar to provide a suitable surface for adhesion of the coating.
- B. Application: Coating shall be applied by brushing until a minimum coating thickness of 20 mils is achieved. Each ensuing coat shall be applied before subsequent coat cures, usually within 3 to 6 hours after subsequent coat has been applied.

3.11 Zinc Anodes

Where called for on the drawings, prepackaged zinc anodes shall be installed in excavated, drilled, or punched holes a minimum of 3-inches larger in diameter than the prepackaged anode diameter. Anodes shall be installed below the level of the service main, with a minimum separation of 2-feet between the copper water tubing and the zinc anode maintained at all times. Anodes shall not be lowered, transported, handled, or lifted by the lead wire.

- A. Backfilling: After the prepackaged anode is placed in the hole, water shall be poured into the hole so that the anode is completely covered with water. Stone-free native soil shall then be used to backfill the anode hole in accordance with Section 02223, Trenching, Backfilling and Compacting. Imported sand shall not be used for backfilling. The anode hole shall be backfilled in stages and carefully compacted to ensure that no voids exist around the bag and that the bag and anode wire are not damaged. After backfill is level with the top of the anode, a minimum of 15 gallons of water shall be poured into the hole to completely saturate the soil backfill. More water shall be added if it is suspected that the backfill is not completely saturated. Care shall be taken to avoid damage to the anode and anode lead wires.
- B. Anode Lead Wire: The anode lead wire shall run to the point of connection at the end of the pipe run in the meter box. The anode lead wire shall be clamped to the copper-tubing riser. Sufficient slack shall be provided in the wire, and it shall be coiled in the meter box

for attachment to a future point of connection at the water meter. At combination air release and vacuum relief valves the anode lead wire shall run through the concrete pad and shall be clamped to the riser as shown in the IRWD Standard Drawings. At blow-offs and manual air releases, anode lead wire shall be coiled in the valve box and clamped to the riser.

3.12 Marker Paddles – Utility Markers

- A. Utility markers shall be installed per District Standard Drawing W-19 at locations shown as directed by the District Representative.

3.13 Insulating Blanket

- A. Install an insulating blanket as shown in the Project Plans between any metallic pipelines that cross or parallel each other when the distance between the two pipelines is less than 18-inches.a

3.14 Earthwork

- A. Trenching, backfilling, and compacting shall be in accordance with Section 02223, Trenching, Backfilling, & Compacting.

3.15 Required Test and Record Keeping

The Contractor shall furnish all necessary equipment, material and qualified personnel required to perform all tests described herein.

- A. Continuity Tests: The Contractor shall notify the District Representative when continuity bonding has been completed and all test boxes have been completed. A registered corrosion engineer or certified NACE CP specialist retained by the Contractor shall oversee and certify the testing and measuring of the electrical continuity of metallic pipelines. The pipeline shall be considered electrically continuous when the measured longitudinal resistance of the pipeline between each pair of adjacent test stations is no greater than 20 percent higher than the theoretical resistance of that section of pipeline.

If tests indicate that adequate electrical continuity has not been achieved, the Contractor shall excavate to investigate and locate improperly bonded joints and shall make repairs until electrical continuity is achieved to the satisfaction of the District.

- B. Test Stations: The Contractor shall notify the District Representative when test station wires are ready for testing. The wires shall remain disconnected to facilitate testing. A registered corrosion engineer or certified NACE CP specialist retained by the Contractor shall oversee and certify the tests to certify that none of the wires were damaged during the installation. If the test indicates damage, the entire wire shall be replaced and retested at the Contractor's expense.

Records shall be made of all test stations and reference electrodes tested and submitted to the District.

- C. Insulation Joints: The Contractor shall test each insulated joint with the insulator tester in accordance with the manufacturer's written instructions. All damaged or defective insulation parts shall be replaced and retested. Records shall be kept of all insulated joint tests and shall be submitted to the District.
- D. Anode and Pipe Lead Wire Integrity Tests: After the pipe and anodes are buried, the pipe lead wire and anode lead wire trenches are backfilled, and the test boxes are installed, the Contractor shall notify the District Representative that the anode and pipe lead wires are ready for testing. The wires shall remain disconnected to facilitate testing. A registered corrosion engineer or certified NACE CP specialist retained by the Contractor shall oversee and certify the tests to confirm that none of the anode wires or pipe lead wires were damaged during the installation. Each anode lead wire will be tested for electrical continuity to the anode by measuring the anode's potential with respect to a copper copper-sulfate reference electrode. The measured open circuit potential of the anode shall be as specified in the table below or as specified by the manufacturer and approved by the District Representative.

Measured Open Circuit Potential for Anodes	
Anode Type	Minimum Measured Open Circuit Potential (Volts)
High Potential Magnesium Anode	1.7
Standard Magnesium Anode	1.4
Zinc Anodes	1.0

- E. Acceptance: The Contractor shall submit a certified report by the corrosion engineer stating that the facilities are performing satisfactorily. All tests made must be reviewed and approved by the District before the corrosion control work is accepted. The District reserves the right to spot check any or all tests performed by the Contractor. All construction defects must be repaired and retested before the final acceptance is made. All unacceptable tests must be re-performed by the Contractor at no additional cost to the District. Contractor shall hook up all lead wires after testing is completed.

END OF SECTION

4. STANDARD DRAWINGS FOR WATER SYSTEMS

DRAFT

LIST OF STANDARD WATER DRAWINGS

STD DWG No.	DRAWING NAME
T-1	LIST OF STANDARD WATER DRAWINGS
W-1	3/4" OR 1" METER SERVICE INSTALLATION (MAXIMUM WORKING PRESSURE 150 PSI)
W-2	1-1/2" TO 2" METER SERVICE INSTALLATION (MAXIMUM WORKING PRESSURE 150 PSI)
W-3	LOCATION OF METERS
W-4	1" OR 2" SERVICE MANIFOLD 1 OF 2
W-4	1" OR 2" SERVICE MANIFOLD 2 OF 2
W-5	FIRE HYDRANT 1 OF 2
W-5	FIRE HYDRANT 2 OF 2
W-6	VALVE BOX, COVER, AND VALVE STEM EXTENSION 1 OF 2
W-6	VALVE BOX, COVER, AND VALVE STEM EXTENSION 2 OF 2
W-7	1" AND 2" AIR AND VACUUM VALVE
W-8	4" CLASS 200 OR 400 BLOW-OFF ASSEMBLY
W-9	2" BLOW OFF ASSEMBLY
W-10	WATER TRENCH
W-11	2" AND SMALLER BACK FLOW PREVENTION DEVICE 1 OF 2
W-11	2" AND SMALLER BACK FLOW PREVENTION DEVICE 2 OF 2
W-12	PIPE INSTALLATION IN CASING PIPE 1 OF 2
W-12	PIPE INSTALLATION IN CASING PIPE 2 OF 2
W-13	MECHANICAL JOINT TAPPING SLEEVE
W-14	BOND JOINT INSTALLATION (STEEL PIPE)
W-15	BONDING FOR PIPE JOINTS AND FITTINGS 1 OF 2
W-15	BONDING FOR PIPE JOINTS AND FITTINGS 2 OF 2
W-16	ALUMINO-THERMIC (CAD) WELDING 1 OF 2
W-16	ALUMINO-THERMIC (CAD) WELDING 2 OF 2
W-17	INSULATOR TEST STATION
W-18	DIELECTRIC CONNECTION TO METALLIC MAIN
W-19	CATHODIC PROTECTION TEST POINT STATION
W-20	THRUST BLOCK 1 OF 6
W-20	THRUST BLOCK 2 OF 6
W-20	THRUST BLOCK 3 OF 6
W-20	THRUST BLOCK 4 OF 6
W-20	THRUST BLOCK 5 OF 6
W-20	THRUST BLOCK 6 OF 6
W-21	CUT IN TEE FOR PVC 1 OF 3
W-21	CUT IN TEE FOR DIP 2 OF 3
W-21	CUT IN TEE FOR ACP 3 OF 3
W-22	CUSTOMER PRESSURE REDUCING ASSEMBLY (FOR PRESSURES 80 PSI AND MORE)
W-23	RETAINING WALL 1 OF 2
W-23	RETAINING WALL 2 OF 2

3/6/2023

\\192.168.1.50\Projects\ECCWD\ECCWD-2022-001 Water Standards Update\900 Engineering\301 CAD\Plansets\T-1.dwg

			EAST ORANGE COUNTY WATER DISTRICT ORANGE, CALIFORNIA	LIST OF STANDARD WATER DRAWINGS	NO SCALE
			APPROVED BY _____ GENERAL MANAGER		STANDARD DWG.
			_____ DISTRICT ENGINEER		T-1
NO.	APPROVED	DATE			

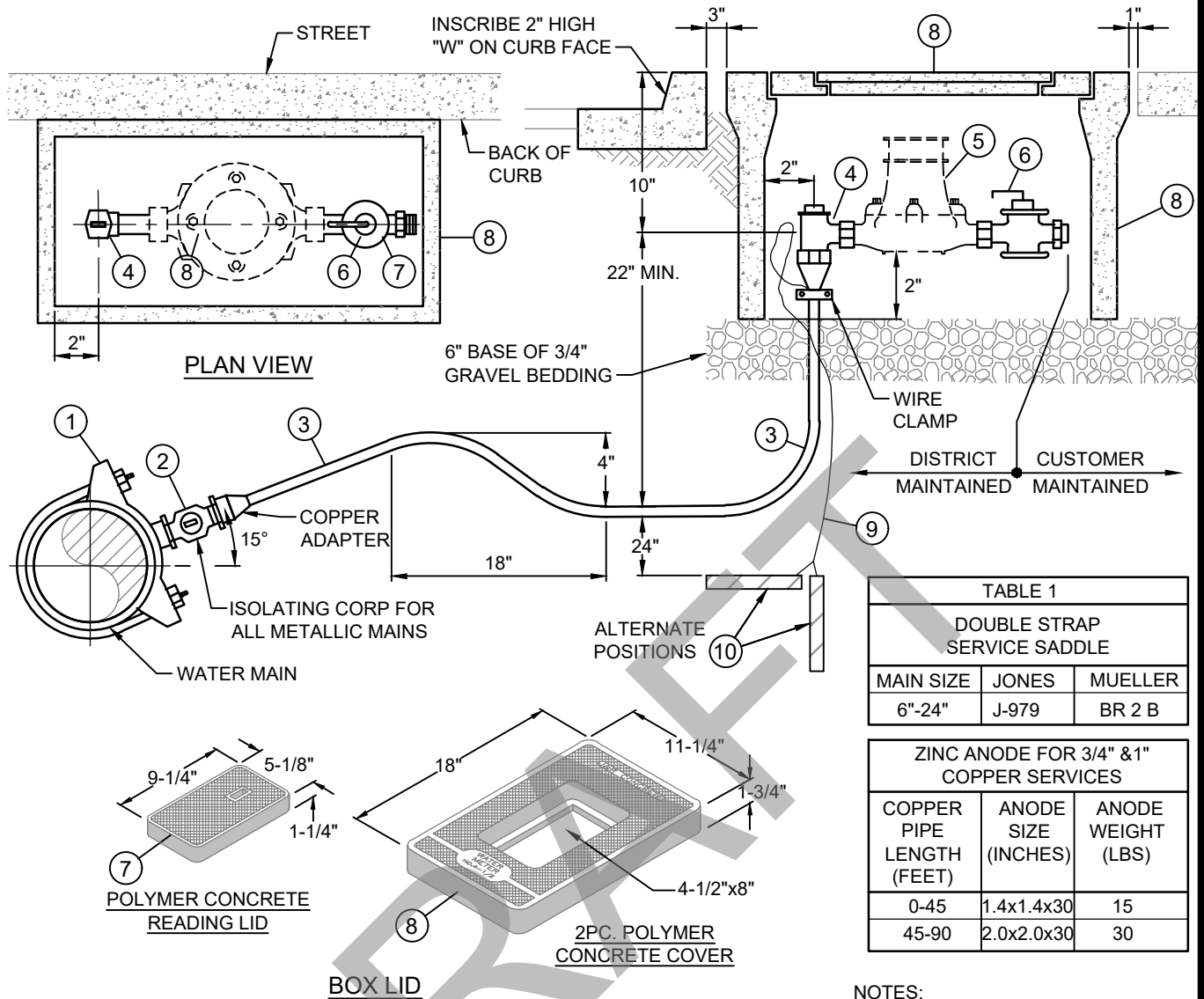

TABLE 1
DOUBLE STRAP SERVICE SADDLE

MAIN SIZE	JONES	MUELLER
6"-24"	J-979	BR 2 B

ZINC ANODE FOR 3/4" & 1" COPPER SERVICES

COPPER PIPE LENGTH (FEET)	ANODE SIZE (INCHES)	ANODE WEIGHT (LBS)
0-45	1.4x1.4x30	15
45-90	2.0x2.0x30	30

- NOTES:**
- REFER TO SPEC. SECTION 15123 FOR SPECIFICATIONS.
 - NO INTERMEDIATE JOINTS PERMITTED WITHOUT APPROVAL OF EOCWD. SERVICE LINES TO RECEIVE BACKFILL OF IMPORTED SAND WITHIN PIPE ZONE (REFER TO STANDARD DRAWING W-10 FOR SPECIFICS).
 - WATER SERVICE SHALL EXTEND PERPENDICULAR TO THE CENTERLINE OF THE STREET FROM THE WATER METER TO THE SERVICE CLAMP.
 - IF METER BOX IS LOCATED ON SLOPE A RETAINING WALL SHALL BE CONSTRUCTED. REFER TO STANDARD DWG W-23.
 - ALL METER BOX LOCATIONS SHALL BE VERIFIED BY EOCWD.

LEGEND LIST OF MATERIALS

ITEM	MATERIALS
①	DOUBLE STRAP SERVICE SADDLE (SEE TABLE 1).
②	CORPORATION STOP FOR PVC MAINS (FOR METALLIC MAINS, SEE W-18). (INSTALL WITH KEY ON SIDE AND OPEN POSITION, UNLESS OTHERWISE DIRECTED).
③	COPPER SERVICE TUBING - SOFT K COPPER (SEE NOTE 2.).
④	ANGLE METER STOP.
⑤	METER (FURNISHED AND INSTALLED BY EOCWD).
⑥	CUSTOMER SERVICE INSULATING BALL VALVE, METER NUT X F.I.P.T.
⑦	9"x5" POLYMER READING LID.
⑧	12" X 20" POLYMER CONCRETE METER BOX AND COVER, J&R CONCRETE NO. P-W4-1/2 OR EQUAL. REFER TO STANDARD DRAWING W-3 FOR LOCATIONS
⑨	AWG NO. 8 HMWPE STRANDED COPPER ANODE LEAD WIRE, LEAVE 18" OF COILED WIRE IN METER BOX.
⑩	PRE PACKAGED ZINC ANODE. ANODE TO BE PLACED VERTICALLY OR HORIZONTALLY AT A MIN. SEPARATION OF 24" FROM COPPER SERVICE LINE. SEE TABLE HEREON FOR ANODE SIZES.

		EAST ORANGE COUNTY WATER DISTRICT ORANGE, CALIFORNIA		3/4" OR 1" METER SERVICE INSTALLATION (MAXIMUM WORKING PRESSURE 150 PSI)	NO SCALE	
		APPROVED BY			STANDARD DWG.	
		GENERAL MANAGER		W-1		
		DATE				
		DISTRICT ENGINEER				
		DATE				
NO.	APPROVED	DATE				

1192-168-1-50Projects\EOCWD\EOCWD-2022-001 Water Standards Update\900 Engineering\301 CAD\Plans\W-1.dwg
 3/6/2023

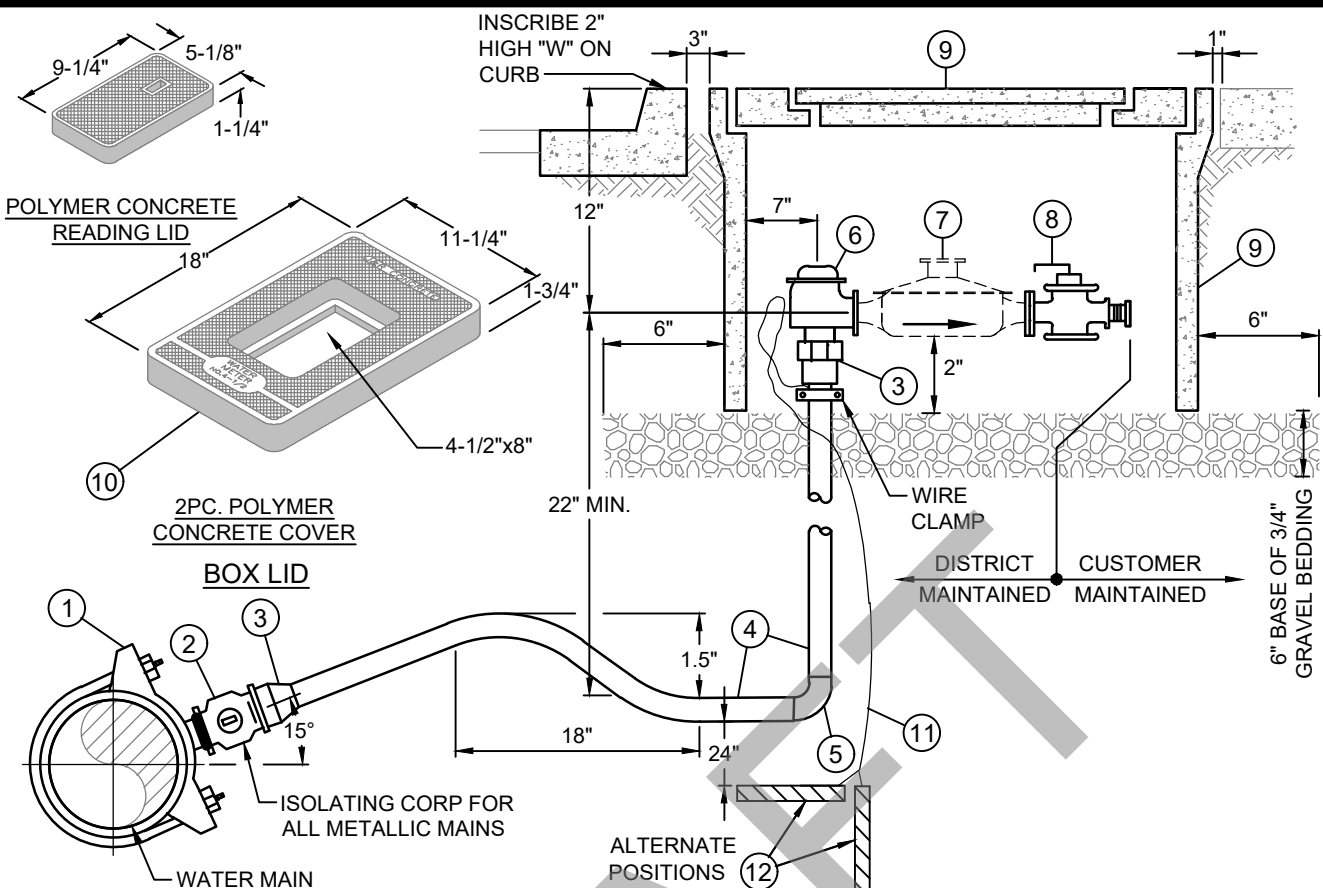

LEGEND LIST OF MATERIALS

- | | |
|---------------------------------------------------------------------------------------------------------------------------------------------------------------------------------------------------------------------------------------------------------------------------------------------------------------------------------------------------------------------------------------------------------------------------------------------------------------------------------------------------------------------------------------------------------------------------------------|------------------------------------------------------------------------------------------------------------------------------------------------------------------------------------------------------------------------------------------------------------------------------------------------------------------|
| <p>① DOUBLE STRAP SERVICE SADDLE</p> <p>② CORPORATION STOP FOR PVC MAINS (FOR METALLIC MAINS, SEE W-18)(INSTALL WITH KEY ON SIDE AND OPEN POSITION, UNLESS OTHERWISE DIRECTED)</p> <p>③ COPPER ADAPTER</p> <p>④ COPPER SERVICE TUBING SOFT K COPPER (SEE NOTE 2.)</p> <p>⑤ 90° ELBOW (COMPRESSION)</p> <p>⑥ ANGLE METER STOP</p> <p>⑦ METER (FURNISHED AND INSTALLED BY EOCWD)</p> <p>⑧ CUSTOMER SERVICE INSULATING BALL VALVE, METER NUT x F.I.P.T.</p> <p>⑨ 17"x30" POLYMER CONCRETE METER BOX AND COVER, J&R CONCRETE NO. PW6B OR EQUAL REFER TO STD DWG W-3 FOR LOCATIONS</p> | <p>⑩ 14"x8" POLYMER CONCRETE READING LID</p> <p>⑪ AWG NO. 8 STRANDED COPPER ANODE LEAD WIRE, LEAVE 18" OF COILDED WIRE IN METER BOX.</p> <p>⑫ PRE PACKAGED ZINC ANODE. ANODE TO BE PLACED VERTICALLY OR HORIZONTALLY AT A MIN. SEPARATION OF 24" FORM COPPER SERVICE LINE. SEE TABLE HEREON FOR ANODE SIZES.</p> |
|---------------------------------------------------------------------------------------------------------------------------------------------------------------------------------------------------------------------------------------------------------------------------------------------------------------------------------------------------------------------------------------------------------------------------------------------------------------------------------------------------------------------------------------------------------------------------------------|------------------------------------------------------------------------------------------------------------------------------------------------------------------------------------------------------------------------------------------------------------------------------------------------------------------|

ZINC ANODE FOR 1-1/2 & 2" COPPER SERVICES		
COPPER PIPE LENGTH (FEET)	ANODE SIZE (INCHES)	ANODE WEIGHT (LBS)
0-22	1.4x1.4x30	15
22-45	2.0x2.0x30	30
45-70	2.0x2.0x48	40
70-90	2.0x2.0x60	60

- NOTES:
- REFER TO SPEC. SECTION 15123 FOR SPECIFICATIONS.
 - NO INTERMEDIATE JOINTS PERMITTED WITHOUT APPROVAL OF EOCWD. SERVICE LINES TO RECEIVE BACKFILL OF IMPORTED SAND WITHIN PIPE ZONE (REFER TO STANDARD DRAWING W-10 FOR SPECIFICS).
 - WATER SERVICE SHALL EXTEND PERPENDICULAR TO THE CENTERLINE OF THE STREET FROM THE WATER METER TO THE SERVICE.
 - IF METER BOX IS LOCATED ON SLOPE A RETAINING WALL SHALL BE CONSTRUCTED. REFER TO STANDARD DWG W-23.
 - ALL METER BOX LOCATIONS SHALL BE VERIFIED BY EOCWD.

3/6/2023
 \\1192-168-1-50\Projects\EOCWD\EOCWD-2022-001 Water Standards Update\900 Engineering\301 CAD\Plansets\W-2.dwg

		EAST ORANGE COUNTY WATER DISTRICT ORANGE, CALIFORNIA APPROVED BY _____ GENERAL MANAGER _____ DATE _____ DISTRICT ENGINEER _____ DATE _____	1-1/2" TO 2" METER SERVICE INSTALLATION (MAXIMUM WORKING PRESSURE 150 PSI)	NO SCALE STANDARD DWG. W-2
NO.	APPROVED	DATE		

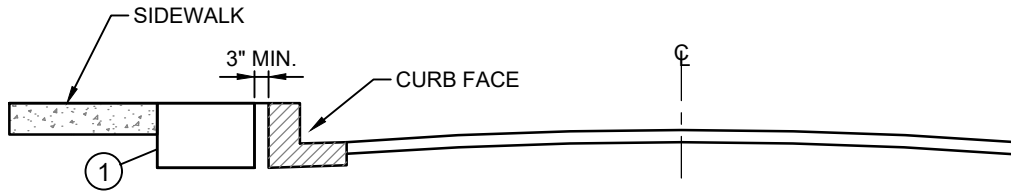

WITH CURB AND SIDEWALK

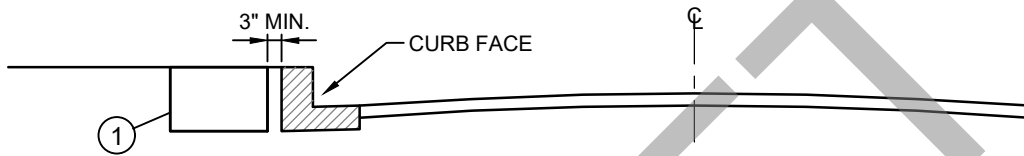

WITH CURB, NO SIDEWALK

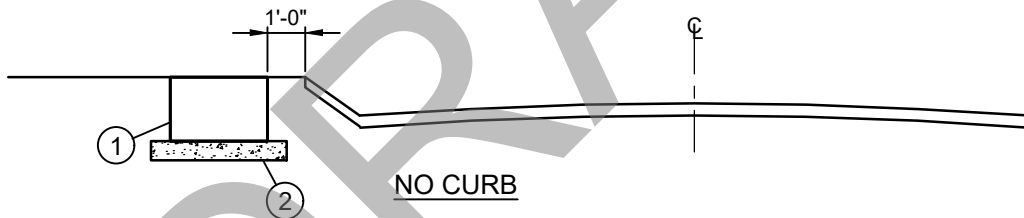

NO CURB

LEGEND LIST OF MATERIALS

ITEM	MATERIALS
①	METER BOX REFER TO STD DRAWINGS W-1 & W-2
②	CLASS A CONCRETE PAD AGAINST UNDISTURBED SOIL. INCLUDE PIPE OPENING AND PVC SLEEVE FOR COPPER SERVICE PIPES.

NOTES:

1. METER BOXES TO BE PERPENDICULAR TO THE CURB AND MINIMUM 3" BEHIND CURB.
2. LOCATION OF SERVICE TO BE PERMANENTLY MARKED ON TOP OF THE CURB WITH A "W" FOR WATER.
3. THE OWNER SHALL BE RESPONSIBLE FOR THE LOCATION AND CONDITION OF ALL SERVICES UNTIL SUCH TIME AS EOCWD HAS ACCEPTED THE WATER SYSTEM.
4. METER BOXES TO BE SET WITH LONGITUDINAL AXIS PARALLEL TO AND 1'-0" BACK OF PAVEMENT EDGE, AND 1" HIGHER THAN FINISH GRADE WITH POLYMER LIDS.
5. LOCATION OF METER BOXES SHALL BE CONFIRMED BY EOCWD.

3/6/2023

\\192-168-1-50\Projects\EOCWD\EOCWD-2022-001 Water Standards Update\900 Engineering\301 CAD\Plans\W-3.dwg

			EAST ORANGE COUNTY WATER DISTRICT ORANGE, CALIFORNIA		NO SCALE	
			APPROVED BY			
			GENERAL MANAGER _____ DATE _____		LOCATION OF METERS	
			DISTRICT ENGINEER _____ DATE _____			
NO.	APPROVED	DATE			STANDARD DWG. W-3	

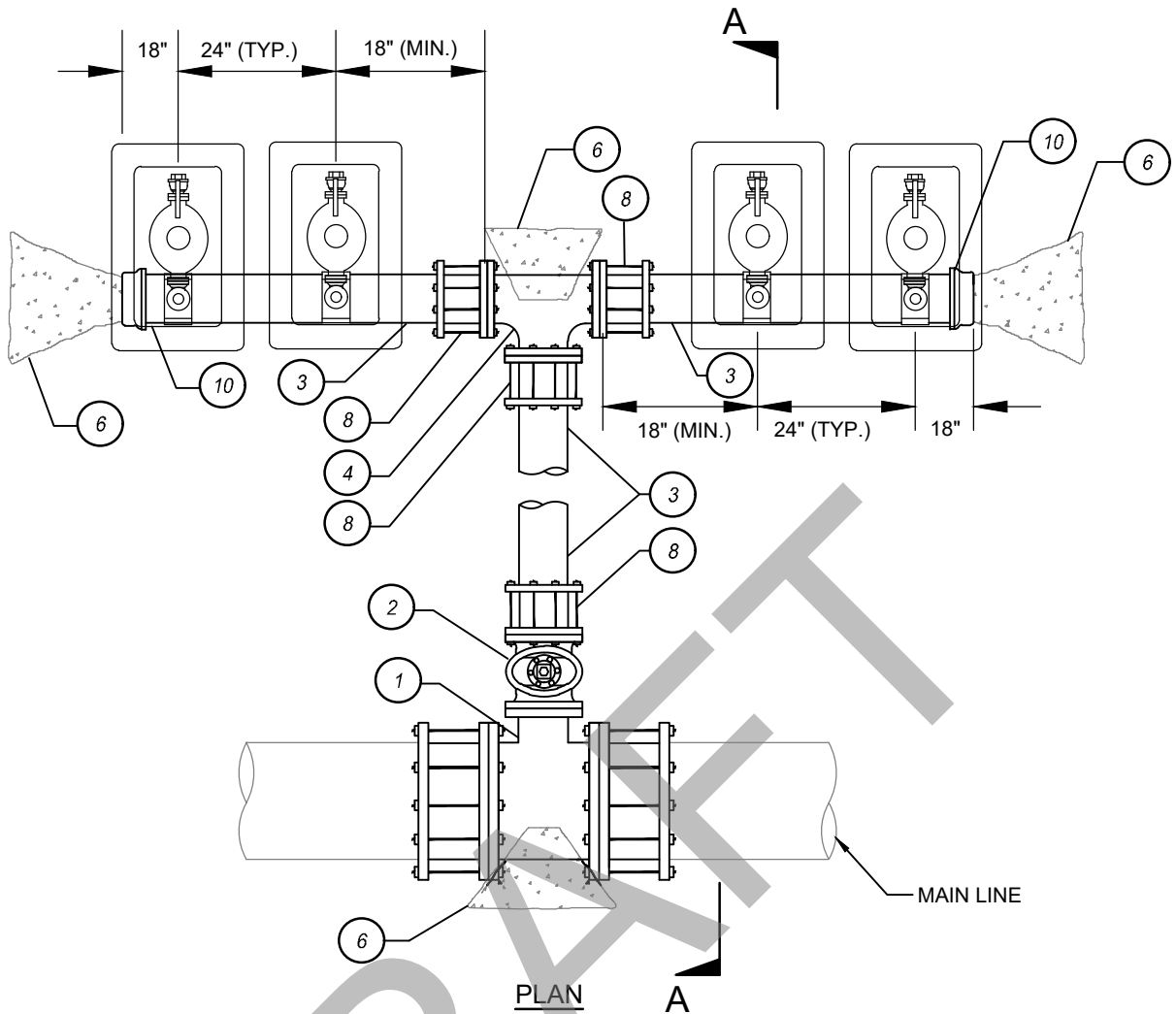

PLAN

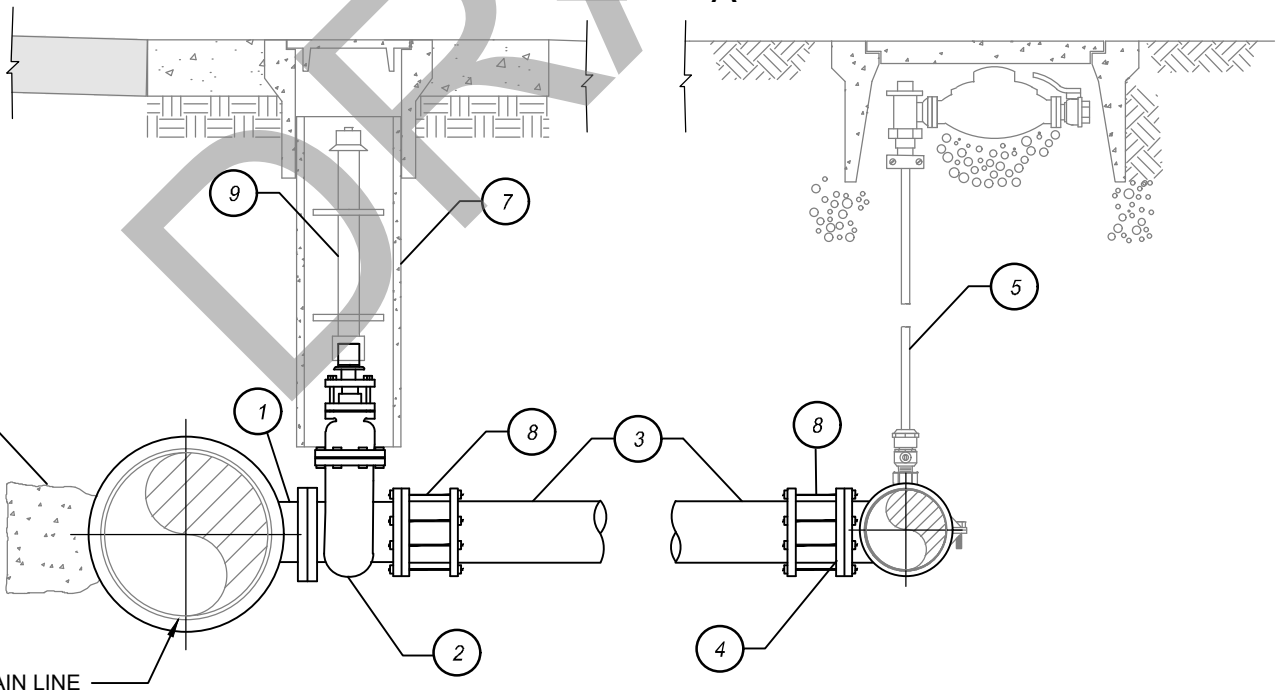

SECTION A-A

3/6/2023

\\192-168-1-50\Projects\ECCWD\ECCWD-2022-001 Water Standards Update\900 Engineering\301 CAD\Plans\W-4.dwg

NO.	APPROVED	DATE

EAST ORANGE COUNTY WATER DISTRICT
ORANGE, CALIFORNIA

APPROVED BY _____
GENERAL MANAGER _____ DATE _____
DISTRICT ENGINEER _____ DATE _____

1" OR 2" SERVICE MANIFOLD
1 OF 2

NO SCALE
STANDARD DWG.
W-4

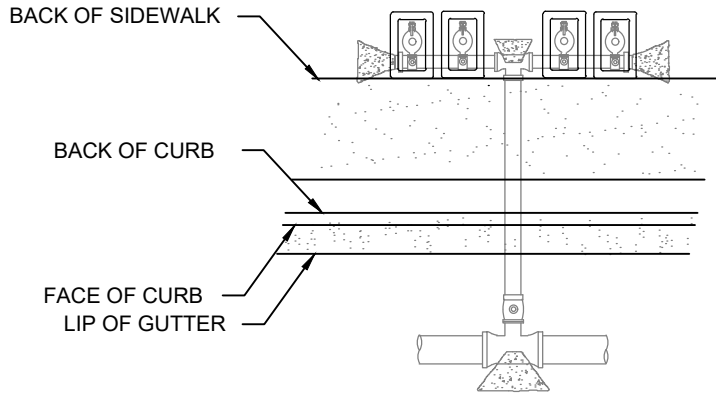

MANIFOLD ADJACENT TO SIDEWALK

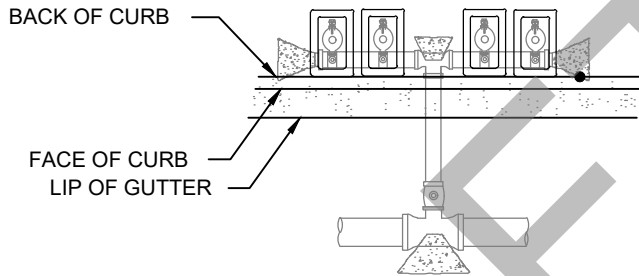

MANIFOLD ADJACENT TO CURB

LEGEND LIST OF MATERIALS

<u>ITEM</u>	<u>MATERIALS</u>
1	MAIN SIZE X 4" D.I. TEE, FLG x FLG
2	4" RW GATE VALVE, FLG x FLG
3	4" C-900 PVC PIPE, DR 14.
4	4" X 4" D.I. TEE, FLG x FLG
5	1" OR 2" SERVICE PER EOCWD STD DWG W-1 AND W-2
6	THRUST BLOCK PER EOCWD STD DWG W-20
7	VALVE BOX PER EOCWD STD DWG W-6
8	4" FLANGED COUPLING ADAPTER
9	VALVE STEM EXTENSION PER EOCWD STD DWG W-6, WHERE APPLICABLE.
10	4" D.I. CAP.

NOTES:

1. THIS ASSEMBLY SHALL NOT BE USED FOR FEWER THAN 4 OR MORE THAN 10 SERVICE CONNECTIONS UNLESS PREVIOUSLY APPROVED BY EOCWD.

3/6/2023

\\192-168-1-50\Projects\EOCWD\EOCWD-2022-001 Water Standards Update\900 Engineering\301 CAD\Plansets\W-4-2.dwg

		EAST ORANGE COUNTY WATER DISTRICT ORANGE, CALIFORNIA		1" OR 2" SERVICE MANIFOLD 2 OF 2	NO SCALE
		APPROVED BY			STANDARD DWG.
		GENERAL MANAGER _____ DATE _____			W-4
NO.	APPROVED	DATE	DISTRICT ENGINEER _____ DATE _____		

FOR LENGTH OVER 30', PIPE DIA. SHALL BE 8"

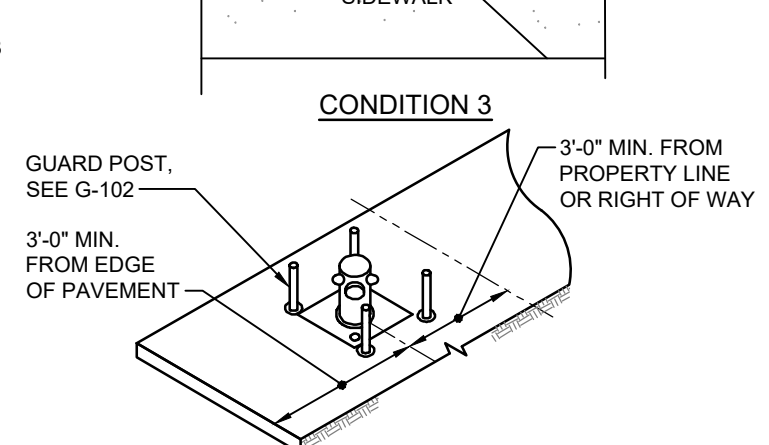
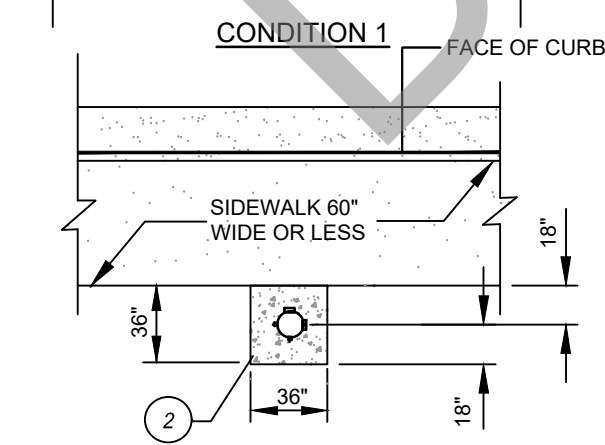
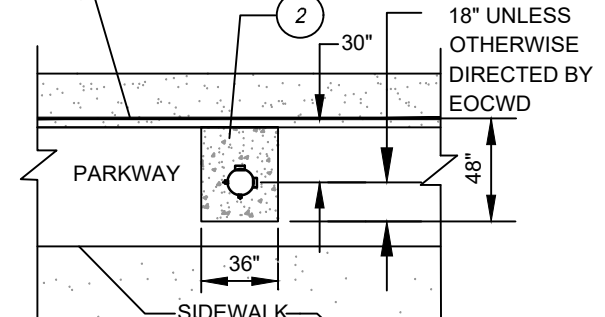
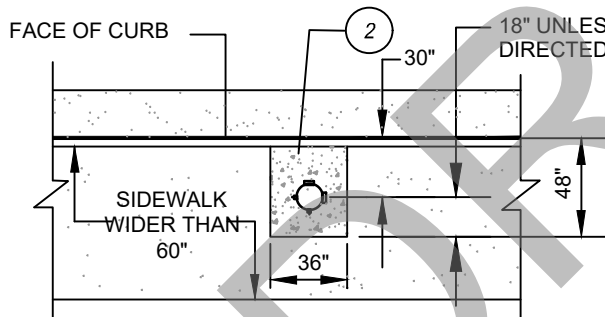
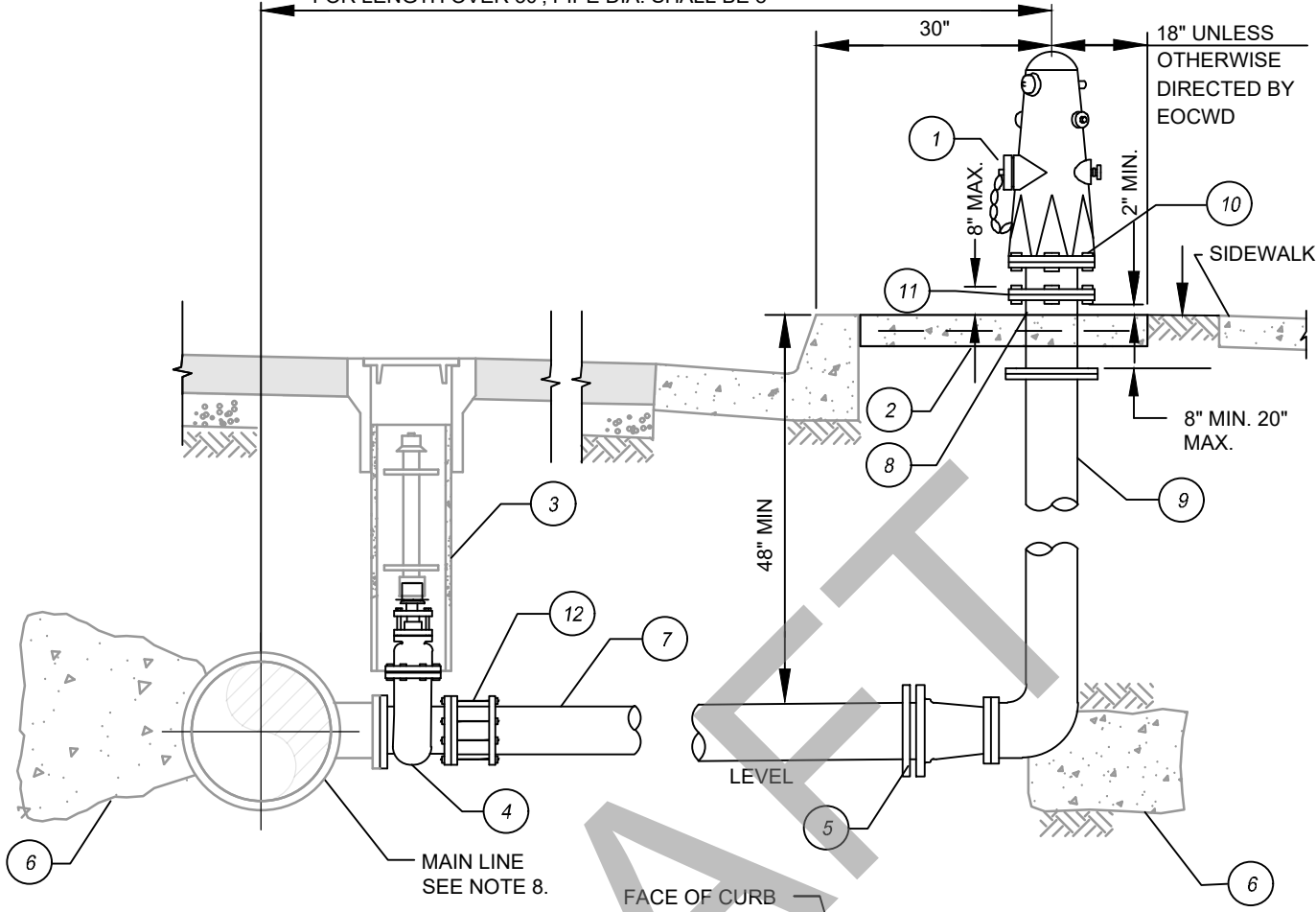

HYDRANT LOCATION PLANS

3/6/2023
\\192.168.1.50\Projects\EOCWD\EOCWD-2022-001 Water Standards Update\900 Engineering\301 CAD\Plans\W-5.dwg

NO.	APPROVED	DATE

EAST ORANGE COUNTY WATER DISTRICT
ORANGE, CALIFORNIA
APPROVED BY _____
GENERAL MANAGER _____ DATE _____
DISTRICT ENGINEER _____ DATE _____

FIRE HYDRANT
1 OF 2

NO SCALE
STANDARD DWG.
W-5

LEGEND LIST OF MATERIALS

<u>ITEM</u>	<u>MATERIALS</u>
①	DUCTILE IRON FIRE HYDRANT ASSEMBLY
②	CONSTRUCT 48" X 36" X 6" THICK OR 36" X 36" X 6" THICK CONCRETE PAD REINFORCED WITH W.W.F. 1.6 X 1.6, SEE HYDRANT LOCATION PLANS ON SHEET 1 OF 2 FOR APPLICABLE CONDITION.
③	VALVE BOX PER EOCWD STD DWG W-6
④	6" OR 8" FLG x FLG RESILIENT WEDGE GATE VALVE
⑤	8" X 6" REDUCER ON LONG SIDE OF STREET, M.J. X F.E. WITH FLANGE BURY (WHERE REQUIRED).
⑥	THRUST BLOCK PER EOCWD STD DWG W-20
⑦	C-900 PVC PIPE OR DIP WHERE REQUIRED.
⑧	SCORED HYDRANT SPOOL. MIN. LENGTH = 12", MAX. LENGTH = 24". ONE SCORE PER SPOOL (SCORED END ABOVE PAD).
⑨	FIRE HYDRANT BURY (42" TYP.).
⑩	CAD-PLATED BREAK-AWAY BOLTS AT HYDRANT FLANGE.
⑪	WHEN SPECIFIED ON THE PLANS, BREAK-OFF CHECK VALVE FOR WET BARREL HYDRANTS (350 PSI PRESSURE RATED, CLOW 619 OR APPROVED EQUAL).
⑫	6" OR 8" FLANGED COUPLING ADAPTER

NOTES:

1. SEE EOCWD STD. SPEC. SECTION 15109 FOR APPROVED HYDRANT TYPES AND ADDITIONAL REQUIREMENTS.
2. HYDRANTS SHALL BE PAINTED CHROME YELLOW.
3. HYDRANT FLANGE GASKET SHALL BE "FULL FACE" AND OF RUBBER COMPOSITION 1/8" THICK.
4. ONE SCORED SPOOL MAY BE UTILIZED TO ADJUST HYDRANT TO GRADE.
5. LOCATE 4" OUTLET PERPENDICULAR TO THE CURB LINE.
6. FILL CAD-PLATED BREAK-AWAY BOLTS WITH SILICONE SEALANT. SEE NOTE 4.
7. COMMERCIAL PROPERTY FIRE HYDRANTS: ORIENTATION OF OUTLETS TO BE DETERMINED BY DISTRICT REPRESENTATIVE.
8. MAIN LINE TEE SHALL BE FLANGED OR MJ RESTRAINT.
9. AT NO POINT SHALL ANY PART OF THE FIRE HYDRANT BE CLOSER THAN 36" AWAY FROM ANY STRUCTURE, LANDSCAPING OR PATH OF TRAVEL.

3/6/2023

\\192.168.1.50\Projects\EOCWD\EOCWD-2022-001 Water Standards Update\900 Engineering\301 CAD\Plans\W-5-2.dwg

			EAST ORANGE COUNTY WATER DISTRICT ORANGE, CALIFORNIA	FIRE HYDRANT 2 OF 2	NO SCALE STANDARD DWG. W-5
			APPROVED BY		
			GENERAL MANAGER	DATE	
NO.	APPROVED	DATE	DISTRICT ENGINEER	DATE	

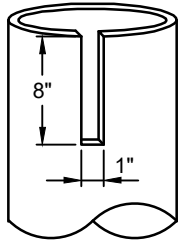
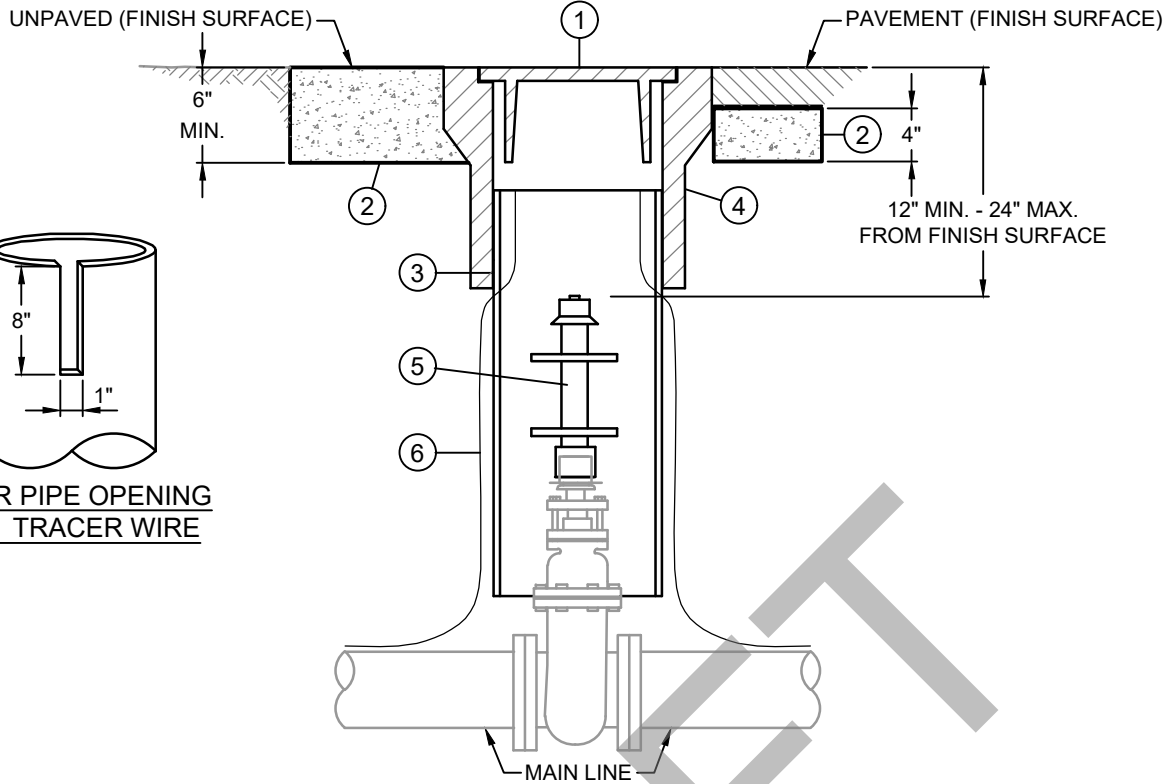

RISER PIPE OPENING
FOR TRACER WIRE

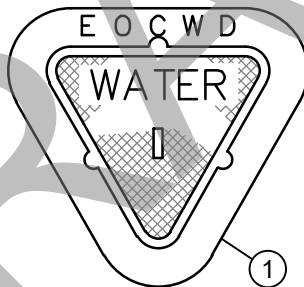

TYPICAL IDENTIFICATION

LEGEND LIST OF MATERIALS

<u>ITEM</u>	<u>MATERIALS</u>
①	10" CAST IRON VALVE BOX AND COVER (BINGHAM AND TAYLOR GRE10R-TF OR EQUAL, REFER TO SPEC. SECTION 15100).
②	CLASS B CONCRETE COLLAR REINFORCED WITH W.W.F. 1.6 x 1.6 IN TURF BLOCK AND UNPAVED CONDITIONS). DO NOT USE CONCRETE COLLAR FOR WATER VALVES WHEN SO DIRECTED BY EOCWD
③	PVC RISER PIPE (8" O.D.) SDR 35
④	10" CAST IRON VALVE CAN
⑤	VALVE EXTENSION (REFER TO SHEET 2 OF 2)
⑥	TRACER WIRE (WHERE REQUIRED BY THE DISTRICT) PER EOCWD STD. DWG. W-10

NOTES:
1. VALVE COVER TO BE IRON WITH LETTERS "EOCWD" CAST THEREON.

3/6/2023
\\192-168-1-50\Projects\EOCWD\EOCWD-2022-001 Water Standards Update\300 Engineering\301 CAD\Plansets\W-6.dwg

NO.	APPROVED	DATE

EAST ORANGE COUNTY WATER DISTRICT ORANGE, CALIFORNIA	
APPROVED BY	
GENERAL MANAGER	DATE
DISTRICT ENGINEER	DATE

**VALVE BOX, COVER AND
VALVE STEM EXTENSION**
1 OF 2

NO SCALE
STANDARD DWG.
W-6

3/6/2023

\\192-168-1-50\Projects\ECCWD\ECCWD-2022-001 Water Standards Update\900 Engineering\301 CAD\Plans\W-6-2.dwg

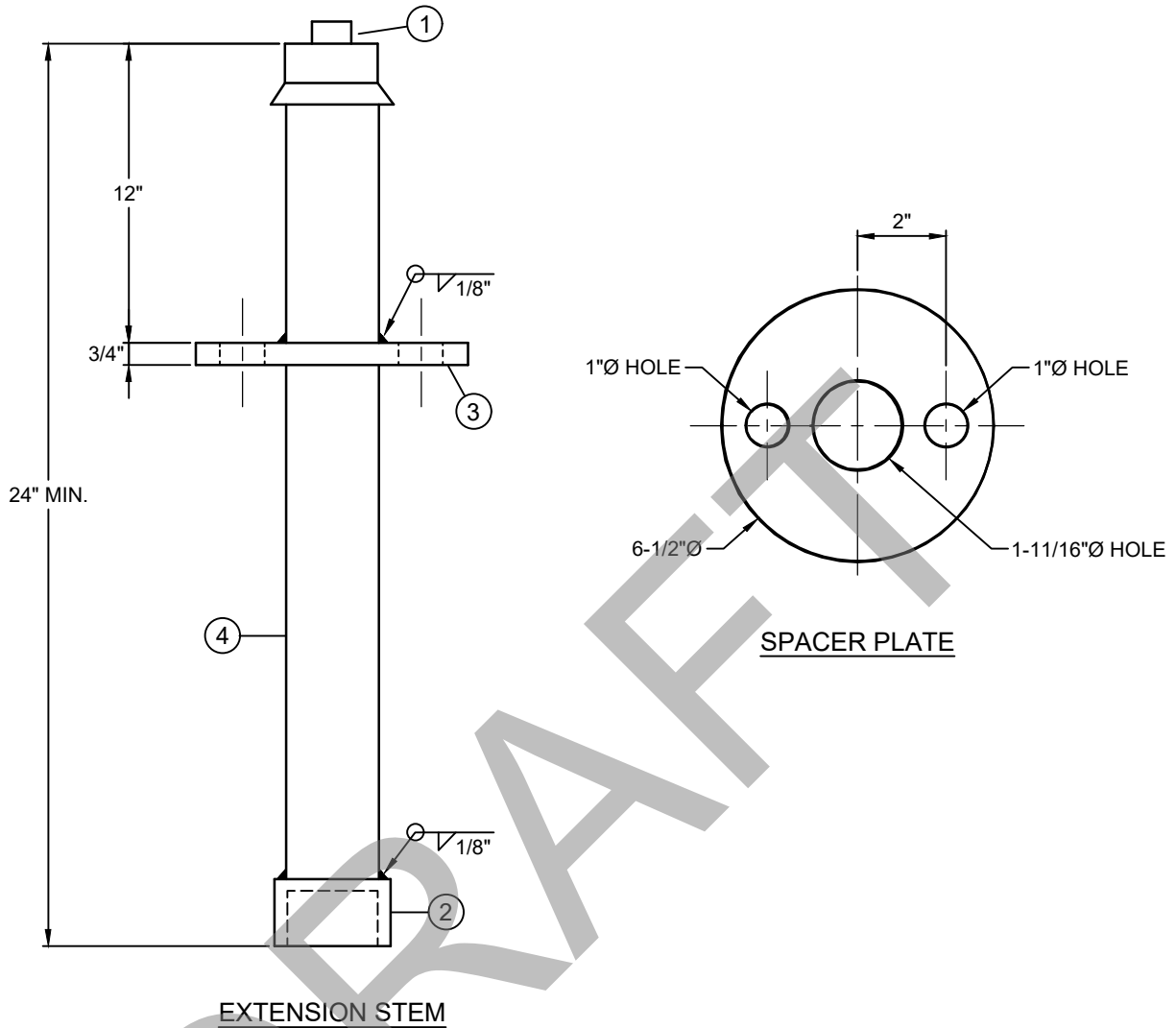

EXTENSION STEM

SPACER PLATE

LEGEND LIST OF MATERIALS

<u>ITEM</u>	<u>MATERIALS</u>
①	A.W.W.A. - 2" SQUARE OPERATING NUT
②	SOCKET - A.W.W.A. 2" SQUARE OPERATING NUT
③	SPACER PLATE (SEE NOTE 3.)
④	EXTENSION STEM (1-1/4" SOLID, ROUND OR SQUARE STAINLESS STEEL BAR STOCK; PINNED COUPLERS ARE UNACCEPTABLE, HOLLOW TUBE OR PIPE ARE NOT ALLOWED)

NOTES:

1. PROVIDE VALVE STEM EXTENSION WHEN DEPTH TO OPERATING NUT EXCEED 48" (FABRICATE EXTENSION TO FIELD MEASUREMENT).
2. NO VALVE STEM EXTENSION SHALL BE LESS THAN 2 FOOT LENGTH. TERMINATE EXTENSION 12" TO 24" FROM FINISHED GRADE.
3. PROVIDE ADDITIONAL SPACER PLATE WHEN DISTANCE TO BOTTOM SOCKET EXCEEDS 5'-0".

NO.	APPROVED	DATE

EAST ORANGE COUNTY WATER DISTRICT ORANGE, CALIFORNIA	
APPROVED BY	
GENERAL MANAGER	DATE
DISTRICT ENGINEER	DATE

**VALVE BOX, COVER, AND
VALVE STEM EXTENSION**
2 OF 2

NO SCALE
STANDARD DWG.
W-6

TABLE 1		
DOUBLE STRAP SERVICE SADDLE		
MAIN SIZE	JONES	MUELLER
6"-24"	J-979	BR 2 B

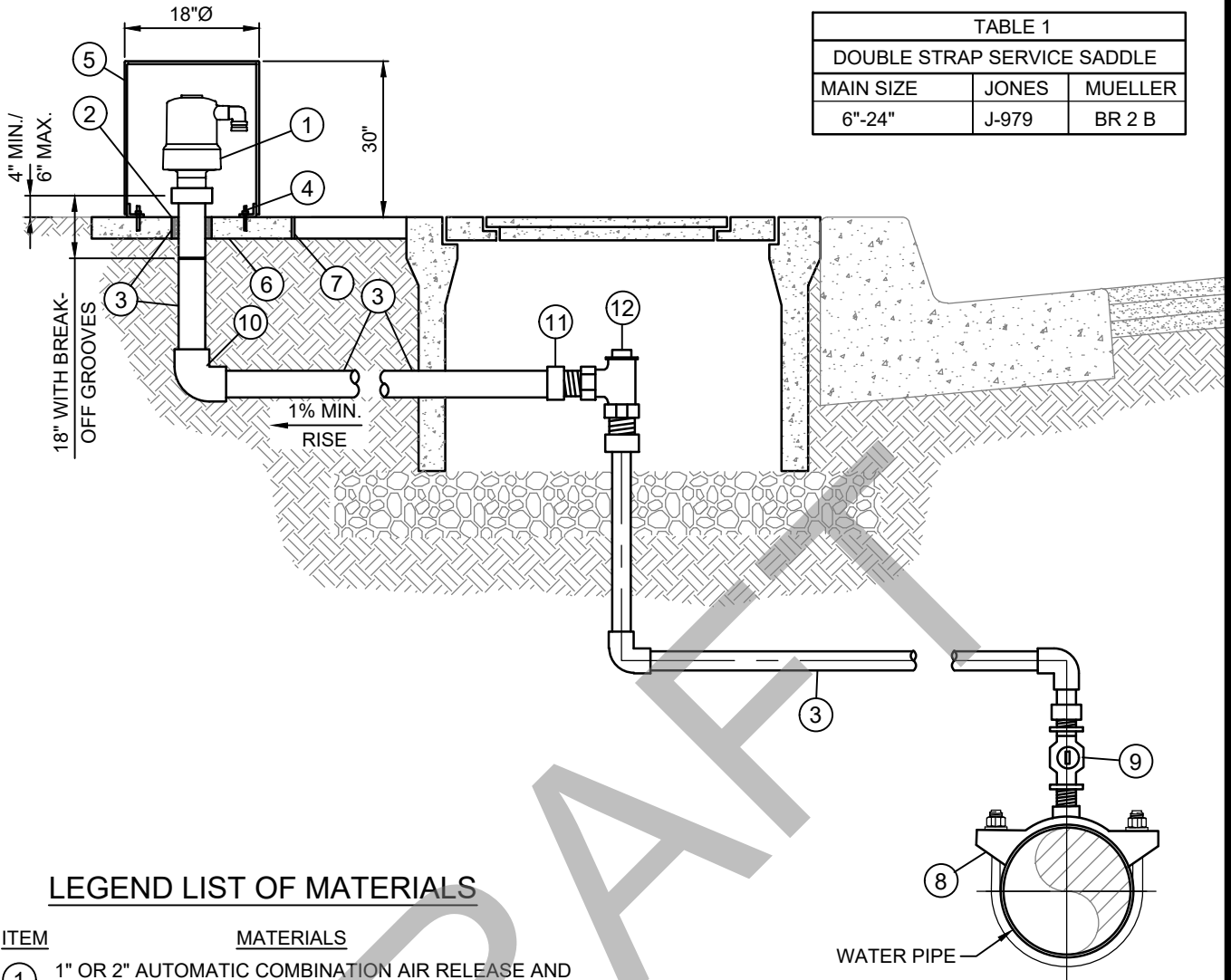

LEGEND LIST OF MATERIALS

ITEM	MATERIALS
①	1" OR 2" AUTOMATIC COMBINATION AIR RELEASE AND AIR/VACUUM VALVE ASSEMBLY A.R.I.D.-040 OR EQUAL
②	4" HOLE, PACK WITH GRAVEL
③	1" OR 2" COPPER PIPE, RIGID SEE NOTE 6
④	5/8" x 3" STAINLESS STEEL DROP-IN ANCHORS (3 EACH AT 12" APART) SEE NOTE 2
⑤	POLYETHYLENE VENTED VALVE ENCLOSURE, SEE NOTE 1.
⑥	36" x36" x 6" THICK CONCRETE SLAB WITH W.W.F. 1.6 X 1.6 IN. REINFORCEMENT.
⑦	COLD JOINT STRIP
⑧	BRASS DOUBLE STRAP SERVICE SADDLE (SEE TABLE 1)
⑨	CORPORATION STOP FOR PVC (WHERE NEEDED) SEE NOTE 4
⑩	1" OR 2" COPPER 90° BEND, COMPRESSION
⑪	ADAPTER
⑫	ANGLE METER STOP

NOTES:

- FOR AREAS PRONE TO FIRE, USE GALVANIZED STEEL COVER COLOR TAN.
- BREAK-AWAY BOLTS SHALL BE 5/8" x 3" WITH 3/8" HOLE DRILLED IN THE SHAFT OF THE BOLT. INSTALL WITH HEX HEAD ON TOP OF FLANGE. FILL CAD-PLATED BREAKAWAY BOLTS WITH SILICONE SEALANT.
- AIR AND VACUUM VALVES INSTALLED FOR THE USE OF POTABLE/RECYCLED WATER SHALL BE IDENTIFIED AS DESCRIBED IN PLANS.
- FOR METALLIC MAINS, USE ISOLATION CORP.
- FOR WORKING PRESSURE ABOVE 150 PSI, USE CLASS 350 VALVES AND FITTINGS.
- NO INTERMEDIATE JOINTS PERMITTED WITHOUT APPROVAL OF EOCWD. SERVICE LINES TO RECEIVE BACKFILL OF IMPORTED SAND WITHIN PIPE ZONE (REFER TO STANDARD DRAWING W-10).

3/6/2023

\\192-168.1.50\Projects\EOCWD\EOCWD-2022-001 Water Standards Update\900.Engineering\301 CAD\Plans\W-7.dwg

EAST ORANGE COUNTY WATER DISTRICT ORANGE, CALIFORNIA	
APPROVED BY	
GENERAL MANAGER	DATE
DISTRICT ENGINEER	DATE

1" AND 2" AIR AND
VACUUM VALVE

NO SCALE
STANDARD DWG.
W-7

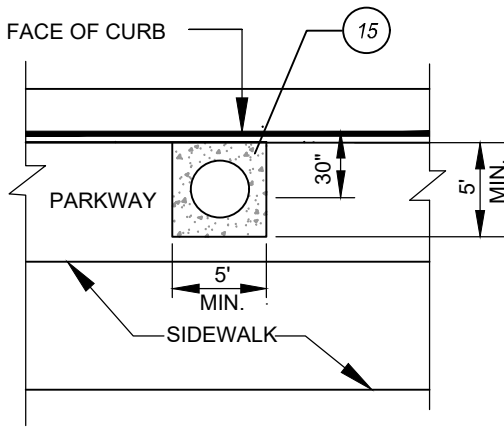

CONDITION 1

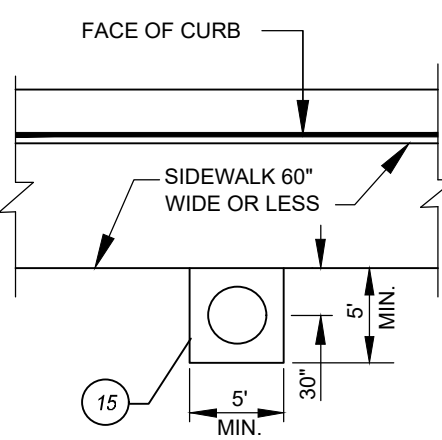

CONDITION 2

BLOW-OFF ASSEMBLY LOCATION PLANS

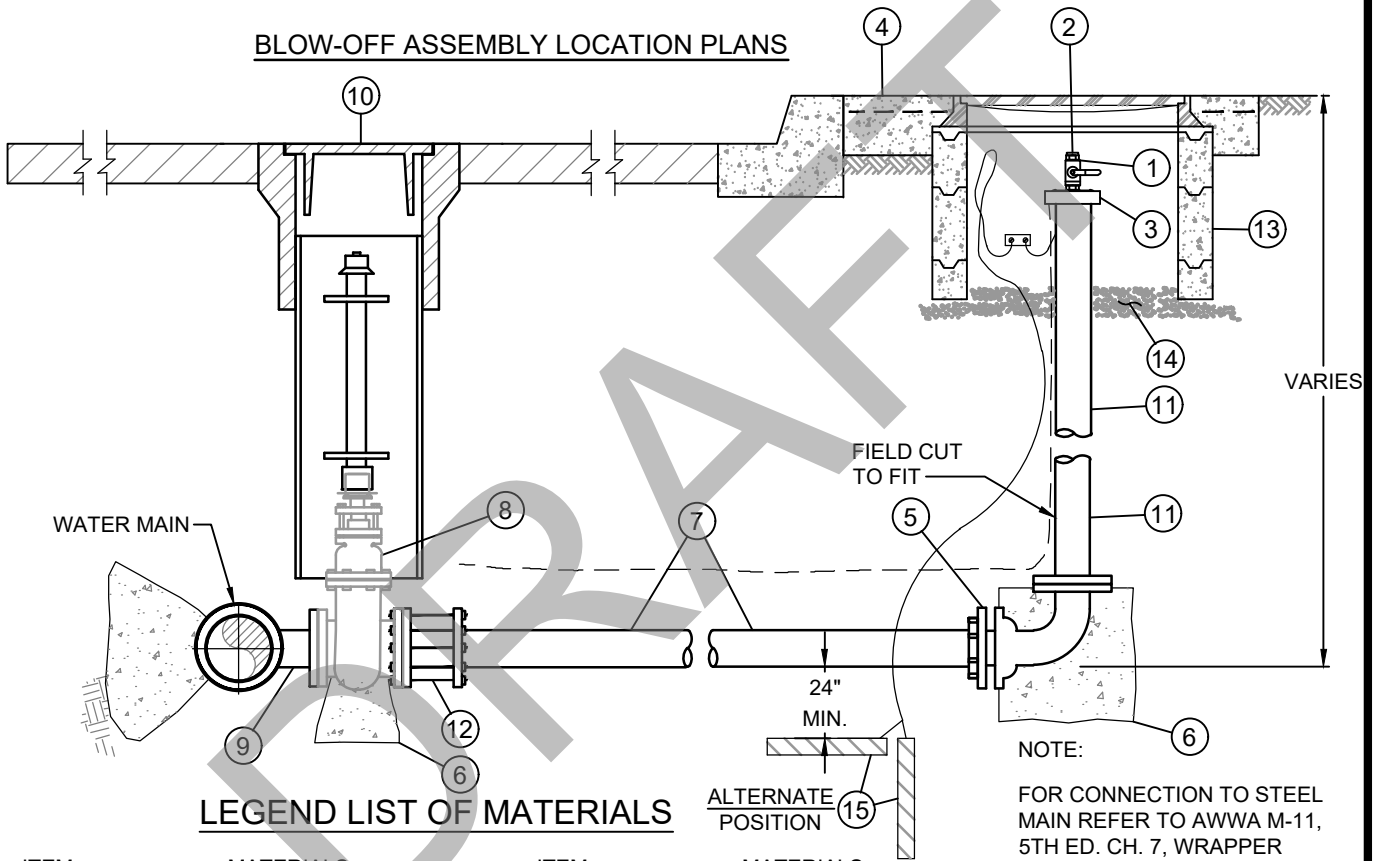

LEGEND LIST OF MATERIALS

ITEM

MATERIALS

- ① STAINLESS STEEL BALL VALVE
- ② 2" THREADED STAINLESS STEEL PLUG
- ③ DI COMPANION FLANGE
- ④ CONCRETE PAD (3'x3'x6")
- ⑤ 90° ELBOW DI, FLG x MJ WITH RESTRAINED JOINT
- ⑥ THRUST BLOCK (REFER TO STANDARD DRAWING W-20)
- ⑦ 4" PVC C900 PIPE
- ⑧ 4" VALVE FLG x FLG RW GATE VALVE

ITEM

MATERIALS

- ⑨ DI TEE (MAIN SIZE X 4" FLANGED OUTLET) SEE NOTE 1.
- ⑩ VALVE BOX AND COVER (REFER TO STANDARD DRAWING W-6 FOR SPECIFICS)
- ⑪ 4" DI PIPE
- ⑫ 12" FLANGED COUPLING ADAPTER
- ⑬ POLYMER METER BOX W ITH LID 17"X30"
- ⑭ 6" BASE OF 3/4" CRUSHED ROCK (EXTENDED 6" BEYOND THE BOX WALLS)
- ⑮ PRE PACKAGED ZINC ANODE. ANODE TO BE PLACED VERTICALLY OR HORIZONTALLY AT A MIN. SEPARATION OF 24" FROM COPPER SERVICE LINE. SEE W-1 FOR ANODE SIZES

NOTE:

FOR CONNECTION TO STEEL MAIN REFER TO AWWA M-11, 5TH ED. CH. 7, WRAPPER PLATE DESIGN.

3/6/2023

\\1192-168-1-50\Projects\ECCOWD\2022-001 Water Standards Update\900 Engineering\301 CAD\Plans\W-8.dwg

EAST ORANGE COUNTY WATER DISTRICT ORANGE, CALIFORNIA		
APPROVED BY		
GENERAL MANAGER	DATE	
DISTRICT ENGINEER	DATE	
NO.	APPROVED	DATE

4" CLASS 200 OR 400
BLOW-OFF ASSEMBLY

NO SCALE
STANDARD DWG.
W-8

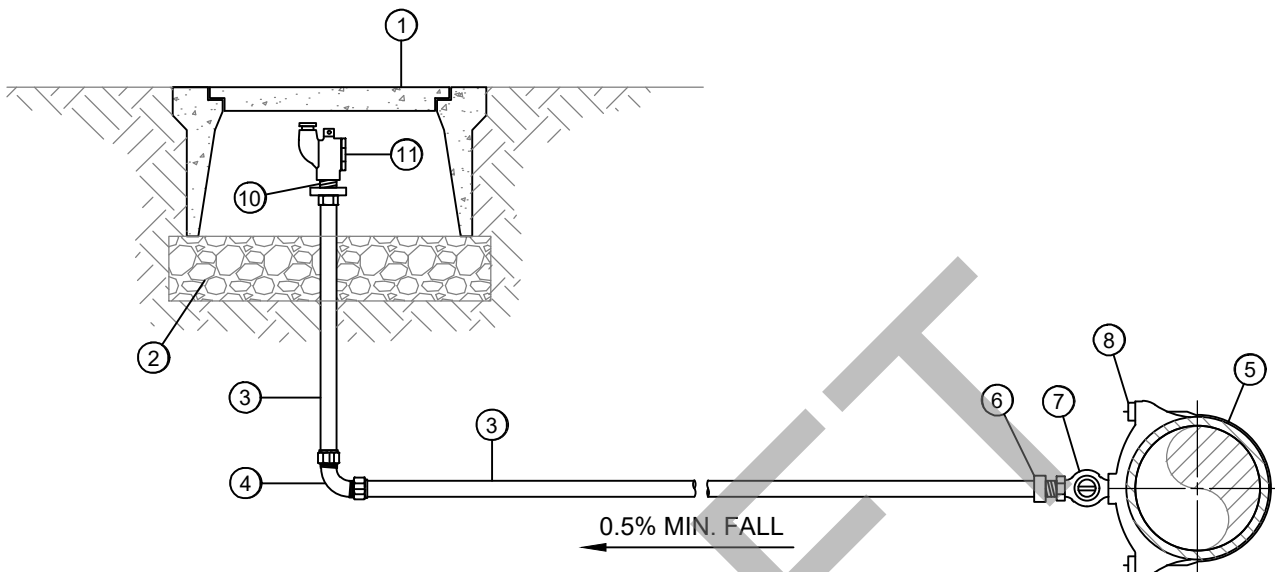

LEGEND LIST OF MATERIALS

ITEM	MATERIALS
①	POLYMER METER BOX WITH LID 17"x30", SEE NOTE 2
②	3/8" ROCK 6" DEEP
③	COPPER PIPE TUBING, SOFT K COPPER
④	90° ELBOW (COMPRESSION)
⑤	WATER MAIN
⑥	COPPER ADAPTER
⑦	BRONZE ISOLATION CORP (WHERE NEEDED) (INSTALL WITH KEY ON SIDE AND OPEN TAP)
⑧	DOUBLE STRAP SERVICE SADDLE
⑨	COMPRESSION MALE ADAPTOR
⑩	ADAPTER
⑪	2" BLOW OFF BALL VALVE, FORD BLA18-777-TAS-NL OR EQUAL.

NOTES:

1. SET TOP OF METER BOX FLUSH WITH SIDE WALK, CURB OR FINISH GRADE.
2. APPROVAL FOR 2" BLOW OFF ASSEMBLY SHALL BE OBTAINED FROM THE EOCWD PRIOR TO INSTALLATION.

3/6/2023

\\192-168-1-50\Projects\EOCWD\EOCWD-2022-001 Water Standards Update\300 Engineering\301 CAD\Plansets\W-9.dwg

NO.	APPROVED	DATE

EAST ORANGE COUNTY WATER DISTRICT ORANGE, CALIFORNIA	
APPROVED BY	
GENERAL MANAGER	DATE
DISTRICT ENGINEER	DATE

2" BLOW OFF ASSEMBLY

NO SCALE
STANDARD DWG.
W-9

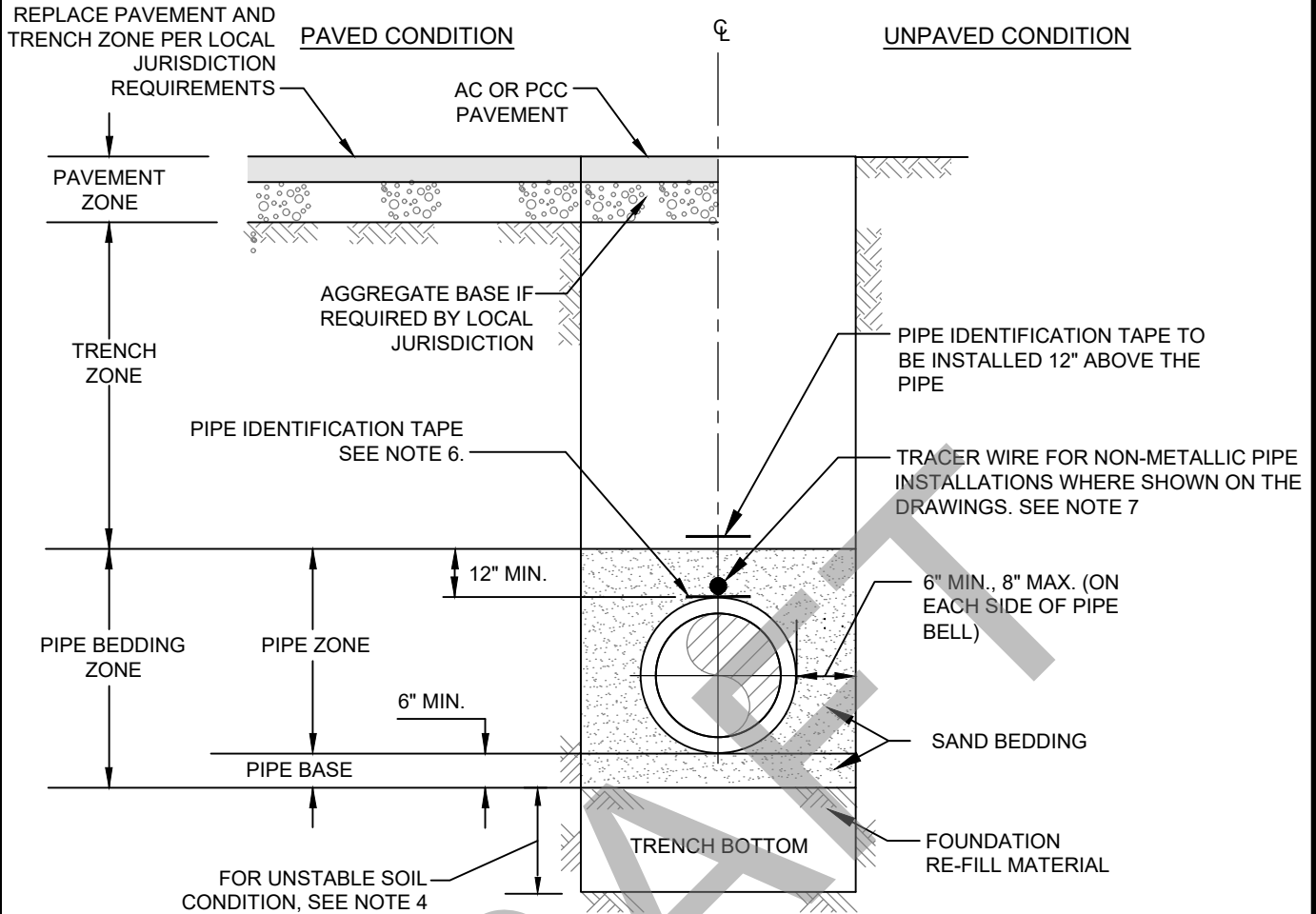

NOTES:

1. ALL WORK SHALL BE PER EOCWD STD. SPEC. SECTION 02223.
2. PIPE BASE SHALL BE A MIN. OF 6" IN DEPTH. PIPE BEDDING MATERIAL SHALL BE PER EOCWD STD. SPEC. SECTION 02223 AND SHALL INCLUDE BOTH PIPE BASE AND PIPE BEDDING ZONE.
3. CONTRACTOR SHALL PROVIDE HAND EXCAVATED "BELL HOLE" FOR EACH PIPE JOINT SO THAT THE WEIGHT OF PIPE DOES NOT BEAR ON THE BELL. CONTRACTOR SHALL RE-FILL AND HAND-TAMP EACH "BELL HOLE" PRIOR TO COMPLETING THE PLACEMENT OF PIPE BEDDING.
4. IF UNSTABLE SOIL IS ENCOUNTERED, THE DISTRICT REPRESENTATIVE SHALL DETERMINE OVER EXCAVATION DEPTH AND FOUNDATION RE-FILL MATERIAL PER EOCWD STD. SPEC. SECTION 02223.
5. WHERE CONTRACTOR FAILS TO MAINTAIN PROPER TRENCH WIDTH LIMITS, SPECIAL BACKFILL SUCH AS ONE-SACK SLURRY AND BEDDING SHALL BE USED AS DETERMINED IN THE FIELD BY THE DISTRICT REPRESENTATIVE OR AS DIRECTED BY JURISDICTION REQUIREMENTS.
6. IDENTIFICATION TAPE SHALL BE 4 MIL INERT PLASTIC FILM SPECIFICALLY FORMULATED FOR PROLONGED UNDERGROUND USE. TAPE WORDING SHALL READ: "CAUTION: DOMESTIC WATERLINE BURIED BELOW".
7. THE TRACER WIRE SHALL CONSIST OF A #8 AWG TYPE UF (DIRECT BURIAL) STRANDED SINGLE CONDUCTOR CABLE WITH HIGH DENSITY POLYETHYLENE (HDPE) OR HIGH MOLECULAR WEIGHT POLYETHYLENE (HMWPE) INSULATION.
8. THE MIN. DEPTH OF COVER FROM FINISH GRADE TO THE TOP OF THE PIPELINE SHALL BE AS FOLLOWS UNLESS OTHERWISE APPROVED BY DIST:
 DOMESTIC WATER PIPELINE (1" TO 10" DIA.) = 42"
 DOMESTIC WATER PIPELINE (> 10" DIA.) = 48"

3/6/2023
 \\1192-168-1-50\Projects\EOCWD\EOCWD-2022-001 Water Standards Update\300 Engineering\301 CAD\Plansets\W-10.dwg

			EAST ORANGE COUNTY WATER DISTRICT ORANGE, CALIFORNIA APPROVED BY _____ GENERAL MANAGER _____ DATE _____ DISTRICT ENGINEER _____ DATE _____	WATER TRENCH	NO SCALE STANDARD DWG. W-10
NO.	APPROVED	DATE			

EOCWD OWNED AND MAINTAINED

CUSTOMER OWNED AND MAINTAINED

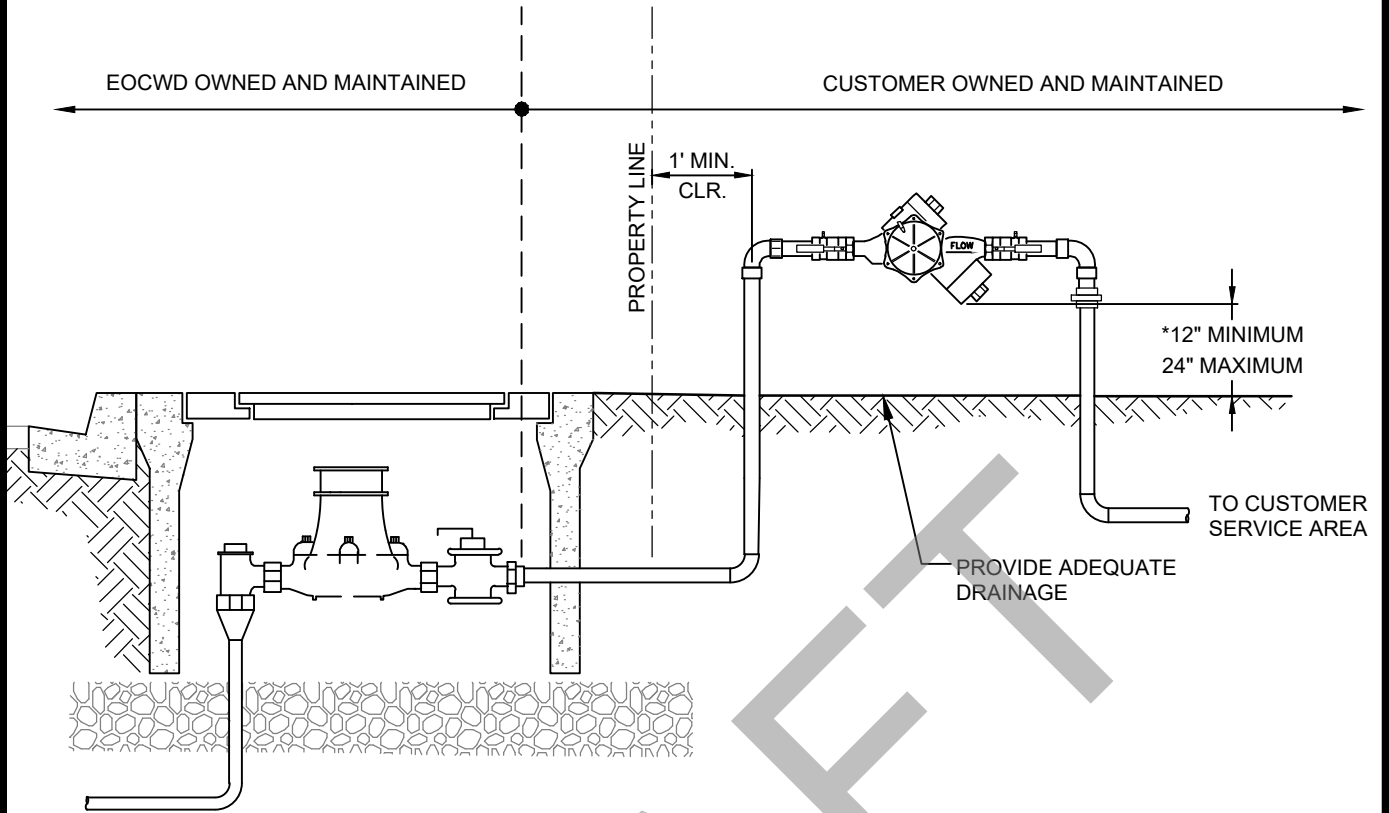

NOTES:

1. BACKFLOW PREVENTION DEVICES SHALL CONFORM TO THE LATEST EDITION OF AWWA C-510 AND SHALL BE APPROVED FOR INSTALLATION BY THE DISTRICT.
2. DEVICE SHALL BE INSTALLED ABOVE GROUND IMMEDIATELY BEHIND AND ON THE CUSTOMER'S SIDE OF THE METER AND SHALL BE READILY ACCESSIBLE FOR TESTING.
3. ALL BACKFLOW DEVICES SHALL BE CERTIFIED BY A BACKFLOW DEVICE TESTER AFTER INSTALLATION.

3/6/2023

\\192.168.1.50\Projects\EOCWD\EOCWD-2022-001 Water Standards Update\900 Engineering\301 CAD\Plans\W-11.dwg

EAST ORANGE COUNTY WATER DISTRICT
ORANGE, CALIFORNIA

APPROVED BY _____
GENERAL MANAGER DATE _____

DISTRICT ENGINEER DATE _____

2" AND SMALLER BACKFLOW PREVENTION DEVICE 1 OF 2

NO SCALE
STANDARD DWG.
W-11

NO.	APPROVED	DATE

3/6/2023

\\192-168-1-50\Projects\ECCWD\ECCWD-2022-001 Water Standards Update\900 Engineering\301 CAD\Plansets\W-11-2.dwg

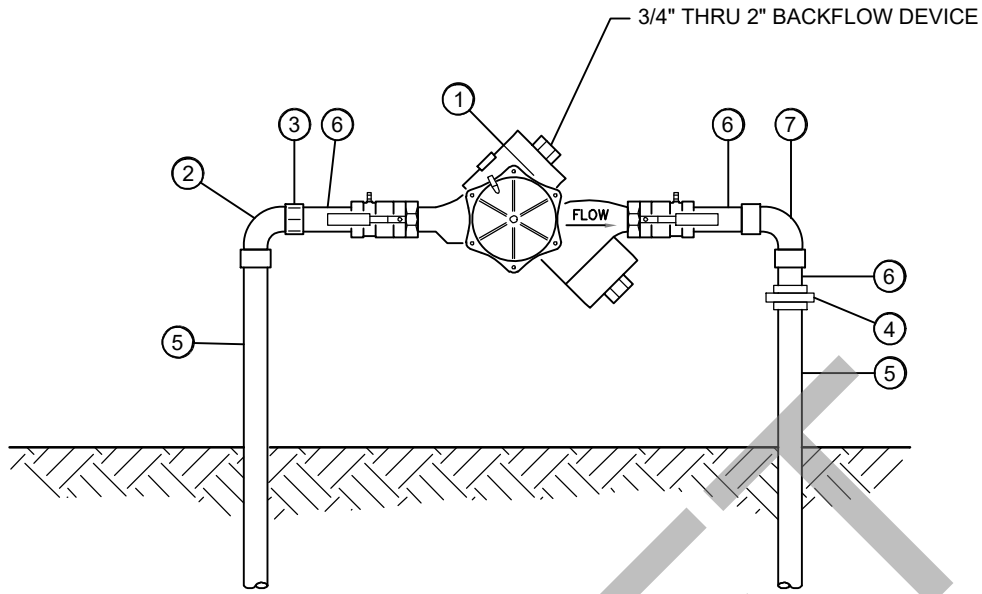

ELEVATION

LEGEND LIST OF MATERIALS

ITEM	MATERIALS
①	APPROVED BACKFLOW PREVENTION ASSEMBLY COPPER 90 DEGREE COPPER 90°
②	COPPER 90° ELBOW (COMPRESSION)
③	COPPER ADAPTER
④	SOLDER UNION
⑤	TYPE "K" COPPER (BURIED PORTION WRAPPED WITH PE)
⑥	BRASS NIPPLES
⑦	BRASS 90° ELBOW (THREADED)

NO.	APPROVED	DATE

EAST ORANGE COUNTY WATER DISTRICT ORANGE, CALIFORNIA	
APPROVED BY	
GENERAL MANAGER	DATE
DISTRICT ENGINEER	DATE

**2" AND SMALLER
BACKFLOW PREVENTION
DEVICE 2 OF 2**

NO SCALE
STANDARD DWG.
W-11

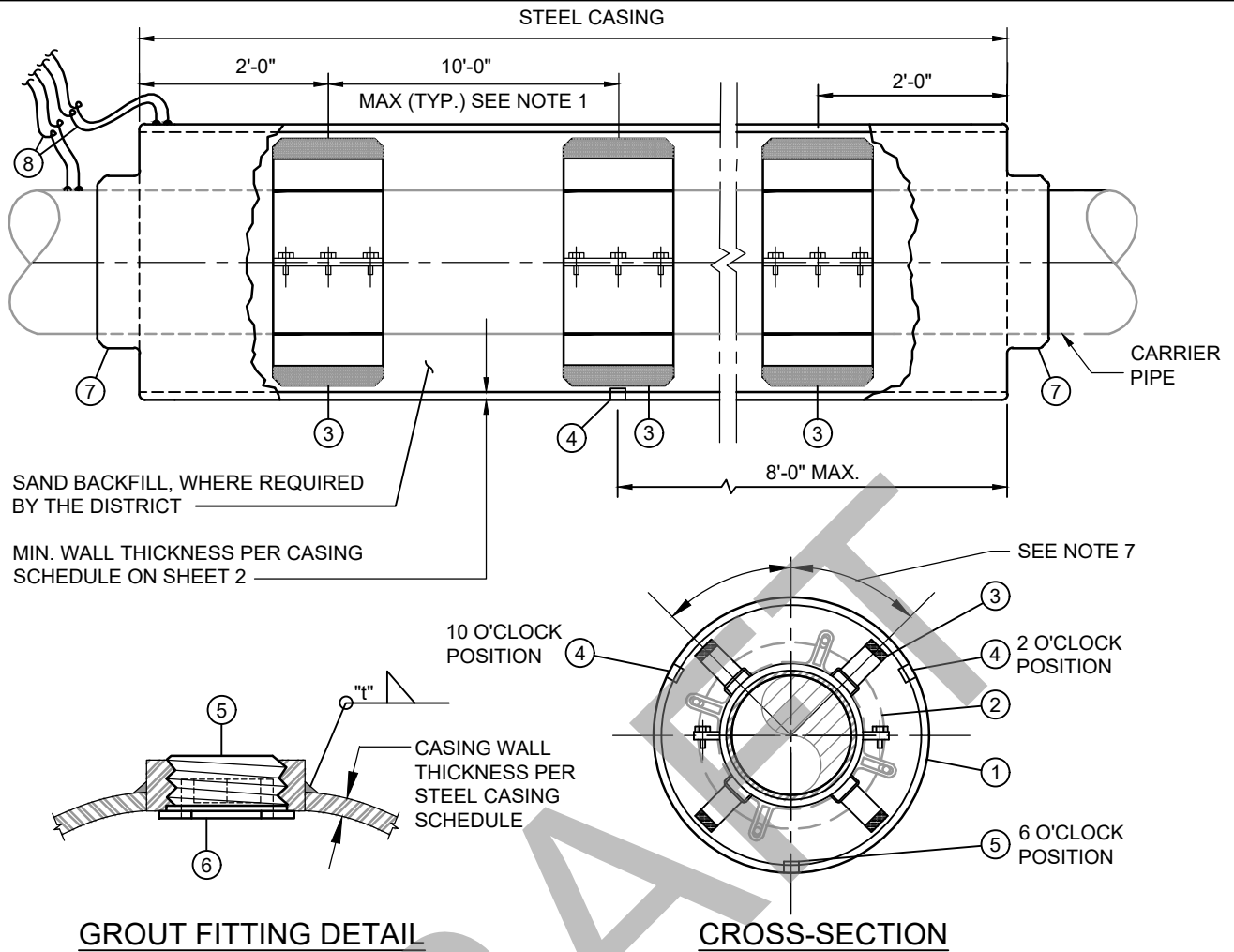

LEGEND LIST OF MATERIALS

- | ITEM | MATERIALS |
|------|----------------------------------------------------------------------------------------------------------------------------------------------------------------------------------------------------------------------------------------------|
| ① | STEEL CASING. |
| ② | CARRIER PIPE JOINT BELL, BEYOND. |
| ③ | STAINLESS STEEL CASING SPACERS WITH UHMW POLYETHYLENE RUNNERS PER SPEC. SECTION 02315. |
| ④ | GROUT FITTING @ 8' O.C. PER DETAIL HEREON. FOR ALL CASINGS 30" IN DIA. AND LARGER, INSTALL ONE COUPLING IN 6 O'CLOCK POSITION @ 8' O.C.; STAGGER COUPLINGS BETWEEN 10 O'CLOCK AND 2 O'CLOCK POSITIONS EVERY 4 LINEAR FEET ALONG CASING AXIS. |
| ⑤ | 2" NPT THREADED STEEL PLUG WITH FLUSH HEAD AND INTERNAL TURN HANDLE. |
| ⑥ | 2" NPT STANDARD WEIGHT STEEL PIPE HALF COUPLING. |
| ⑦ | CASING END SEAL PER SPEC. SECTION 02315 WITH STAINLESS STEEL WORM-SCREW BAND CLAMPS. |
| ⑧ | CASING TEST STATION PER EOCWD STD. DWG. W-19. |

NOTE:
 1. SPACING TO BE PER MANUFACTURER'S INSTRUCTIONS BUT IN NO CASE GREATER THAN THE MAXIMUM NOTED HERE.

3/6/2023
 \\192.168.1.50\Projects\EOCWD\EOCWD-2022-001 Water Standards Update\300 Engineering\301 CAD\Plansets\W-12.dwg

		EAST ORANGE COUNTY WATER DISTRICT ORANGE, CALIFORNIA		PIPE INSTALLATION IN CASING PIPE 1 OF 2		NO SCALE	
		APPROVED BY				STANDARD DWG.	
		GENERAL MANAGER		DATE		W-12	
NO.		APPROVED		DATE			
		DISTRICT ENGINEER		DATE			

STEEL CASING SCHEDULE (PVC PIPE) TABLE 1		
PIPE SIZE	MINIMUM CASING SIZE (NOMINAL)	MINIMUM WALL THICKNESS
6"	16"	5/16"
8"	18"	5/16"
10"	20"	3/8"
12"	24"	3/8"
15"	27"	3/8"
18"	30"	1/2"
24"	42"	1/2"

(1) CARRIER PIPE IN THE STEEL CASING SHALL BE RESTRAINED JOINT

TABLE 2 CASING AND MATERIAL SCHEDULE				
NOMINAL CARRIER PIPE SIZE	CASING MATERIAL		FILL ANNULAR SPACE BETWEEN CASING AND CARRIER PIPE	
	BURIAL DEPTH TO TOP OF CARRIER PIPE			
	10-FEET AND LESS	GREATER THAN 10-FEET	10-FEET AND LESS	GREATER THAN 10-FEET
4"-16"	PVC	STEEL	NO	YES
18"-24"	STEEL	STEEL	NO	YES

NOTES:

1. SIZE AND THICKNESS OF CASING SHALL BE AS SHOWN IN TABLE 1.
2. ALL STEEL CASING PIPE FIELD JOINTS SHALL BE WELDED FULL-CIRCUMFERENCE.
3. CARRIER PIPE SHALL BE PRESSURE TESTED PRIOR TO SEALING ENDS OF CASING.
4. EACH END OF CASING SHALL BE SEALED WITH APPROVED RUBBER CASING END SEALS.
5. NUMBER AND PLACEMENT OF SPACERS ON CARRIER PIPE PER MANUFACTURER'S SPECIFICATION.
6. ALL CARRIER PIPE JOINTS INSIDE THE STEEL CASING AND A MIN. 5' OUTSIDE STEEL CASING SHALL BE RESTRAINED.
7. REFER TO TABLE 2, AND SPEC SECTIONS 02315 FOR ANNULAR SPACE FILL REQUIREMENTS.
8. FOR PIPES LARGER THAN 24" ENGINEER SHALL CALCULATE CASING SIZE AND THICKNESS AND SUBMIT TO THE DISTRICT FOR APPROVAL.

3/6/2023

\\192-168-1-50\Projects\EOCWD\ECOWD-2022-001 Water Standards Update\900 Engineering\301 CAD\Plansets\W-12-2.dwg

		EAST ORANGE COUNTY WATER DISTRICT ORANGE, CALIFORNIA		PIPE INSTALLATION IN CASING PIPE 2 OF 2	NO SCALE	
		APPROVED BY			STANDARD DWG.	
		GENERAL MANAGER _____ DATE _____		W-12		
		DISTRICT ENGINEER _____ DATE _____				
NO.	APPROVED	DATE				

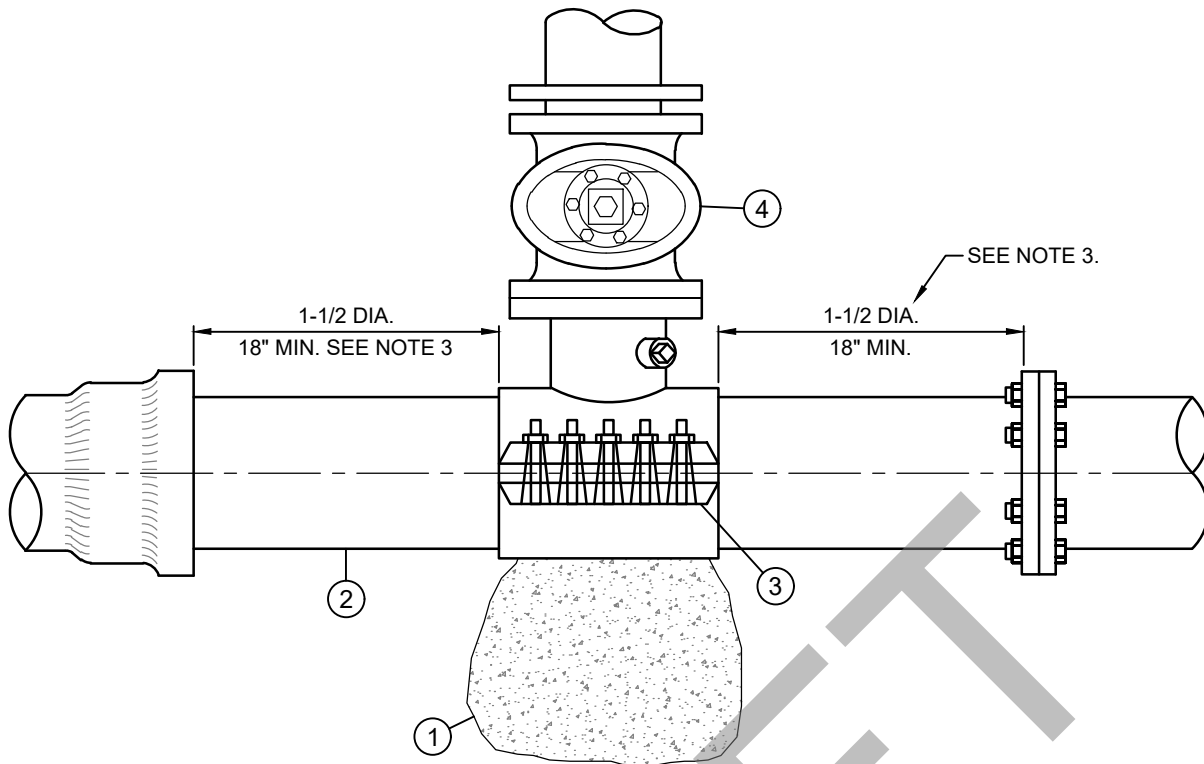

PLAN VIEW

LEGEND LIST OF MATERIALS

<u>ITEM</u>	<u>MATERIALS</u>
①	THRUST BLOCK (REFER TO STANDARD DRAWING W-20)
②	PVC, ACP, OR DI MAIN
③	TAPPING SLEEVE (STAINLESS STEEL, MEET REQUIREMENT OF AWWA C223, ROMAC, MUELLER, SMITH-BLAIR OR EQUAL)
④	RESILIENT WEDGE GATE VALVE

NOTES:

1. PRIOR TO TAPPING THE WATER MAIN, THE TAPPING SLEEVE AND VALVE SHALL BE ATTACHED TO THE WATER MAIN AND PRESSURE TESTED FOR FIVE MINUTES AT 150 PSI.
2. NEW LINE AND TAPPING SLEEVE MUST BE AT LEAST 2" OR SMALLER THAN THE EXISTING MAIN.
3. TAPPING SLEEVE SHALL BE SEPARATED FROM NEAREST BELL, FLANGE, SERVICE CLAMP, CORP STOP, OR OTHER FITTING BY A DISTANCE NO LESS THAN 1-1/2 PIPE DIAMETERS, WITH A MINIMUM OF 18".
4. ALL FITTINGS SHALL BE WRAPPED WITH 4 MIL. POLYETHYLENE SHEETS PRIOR TO POURING CONCRETE BLOCKING.

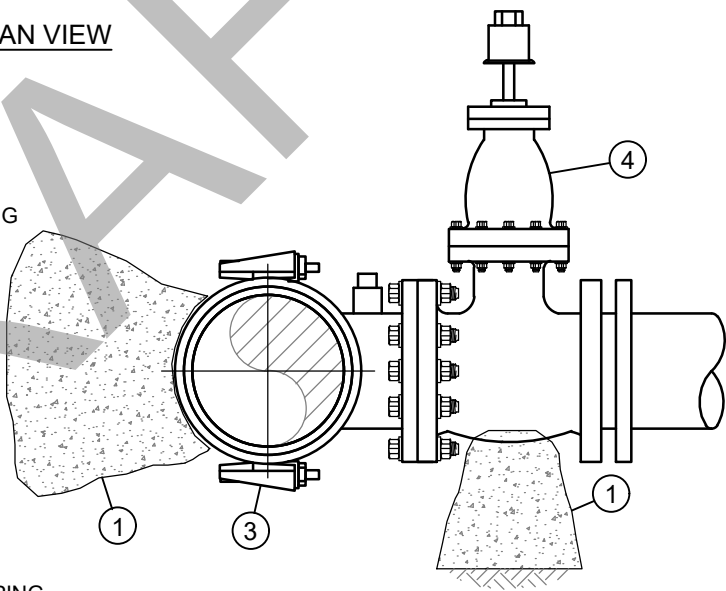

ELEVATION

3/6/2023
 \\192-168-1-50\Projects\ECCWD\ECOWD-2022-001 Water Standards Update\900-Engineering\301 CAD\Plansets\W-13.dwg

NO.	APPROVED	DATE

EAST ORANGE COUNTY WATER DISTRICT ORANGE, CALIFORNIA	
APPROVED BY	
GENERAL MANAGER	DATE
DISTRICT ENGINEER	DATE

**MECHANICAL JOINT TAPPING
SLEEVE**

NO SCALE
STANDARD DWG.
W-13

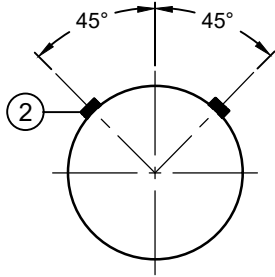

NOTE:
3 WIRES FOR 18" AND
LARGER PIPES.

PLACEMENT DIAGRAM

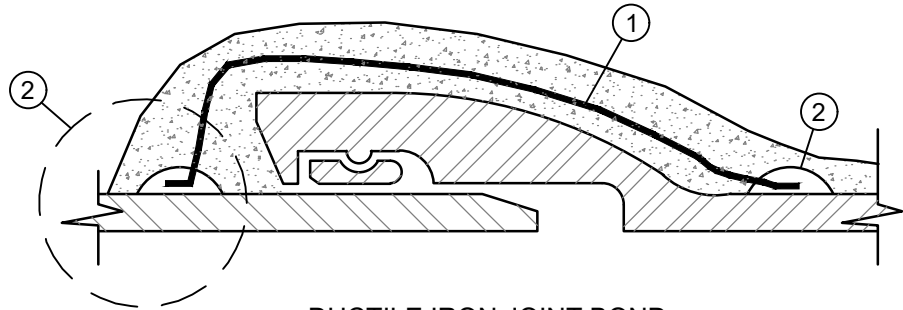

DUCTILE IRON JOINT BOND

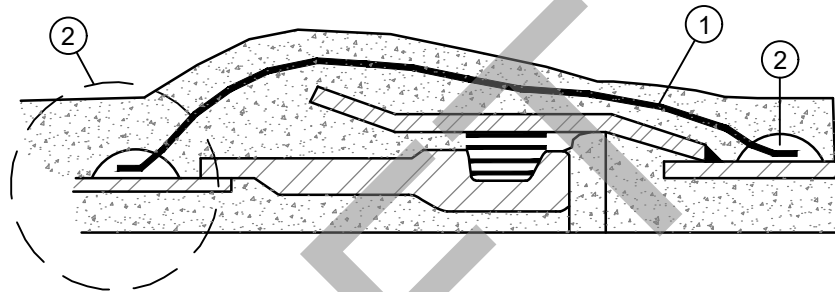

STEEL JOINT BOND

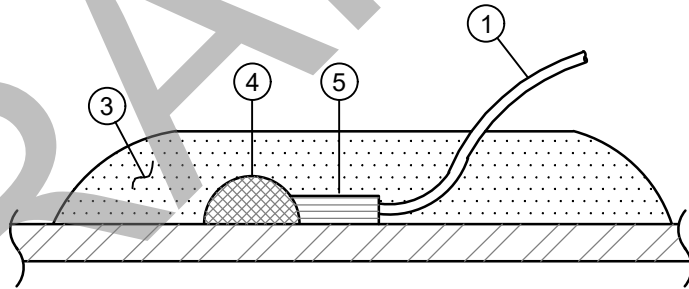

BOND WIRE CONNECTION DETAIL

WELDS SHOULD BE 6" MIN AWAY FROM GASKETED JOINT

LEGEND LIST OF MATERIALS

ITEM	MATERIALS
①	WIRE (SEE NOTE 2.)
②	BOND WIRE CONNECTION (2 TYP.)
③	EPOXY PUTTY, MOISTURE TOLERANT, HIGH STRENGTH, SIKADUR 32 OR EQUAL
④	EXOTHERMIC WELD
⑤	COPPER SLEEVE

NOTES:

1. PIPE SURFACE AROUND WELD
MUST BE CLEANED TO
PROVIDE A SOUND, CLEAN
DRY METAL SURFACE.
RECOAT ALL EXPOSED METAL.

2. PIPE SIZE (INCHES)	WIRE SIZE (AWG NO.)
4-10	#6
12-16	#4
20-27	#4

3/6/2023

\\192.168.1.50\Projects\ECCWD\ECCWD-2022-001 Water Standards Update\900 Engineering\301 CAD\Plansets\W-14.dwg

NO.	APPROVED	DATE

EAST ORANGE COUNTY WATER DISTRICT ORANGE, CALIFORNIA	
APPROVED BY	
GENERAL MANAGER	DATE
DISTRICT ENGINEER	DATE

BOND JOINT INSTALLATION

NO SCALE
STANDARD DWG.
W-14

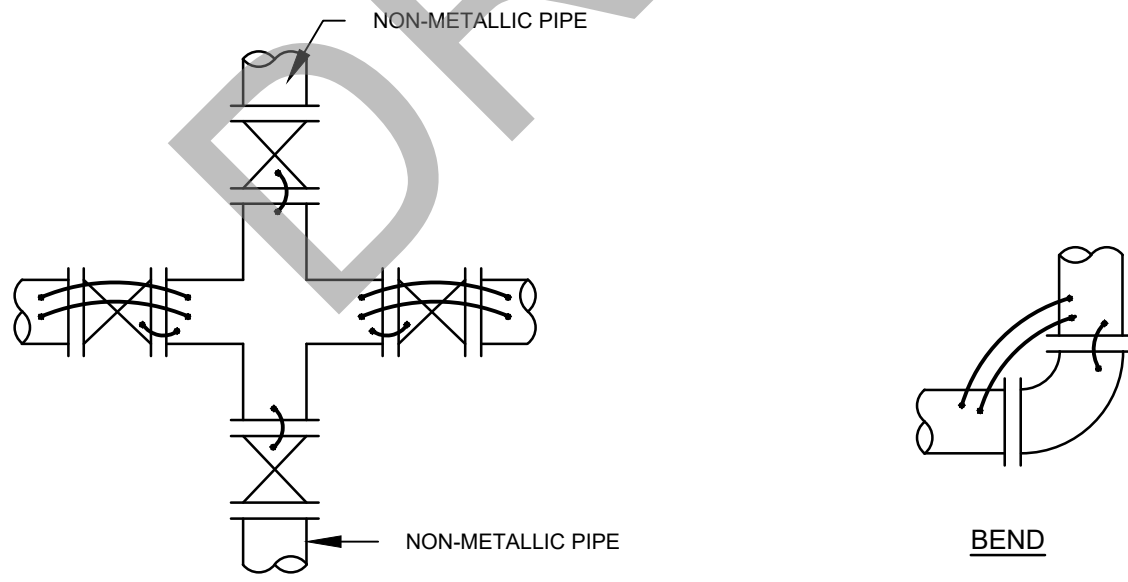
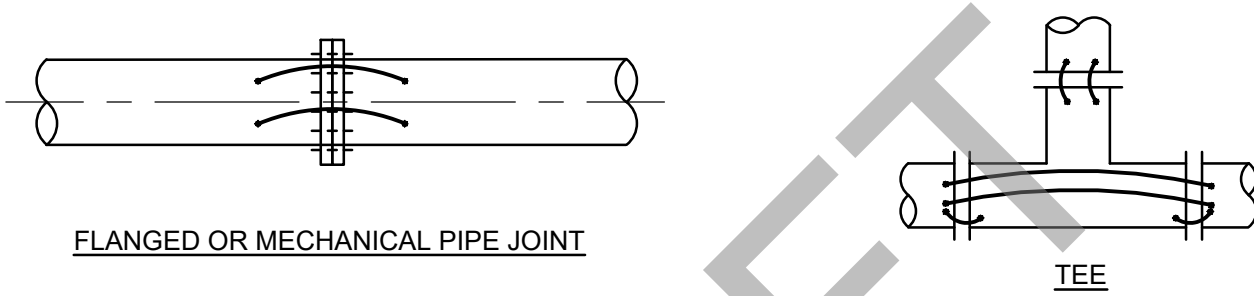
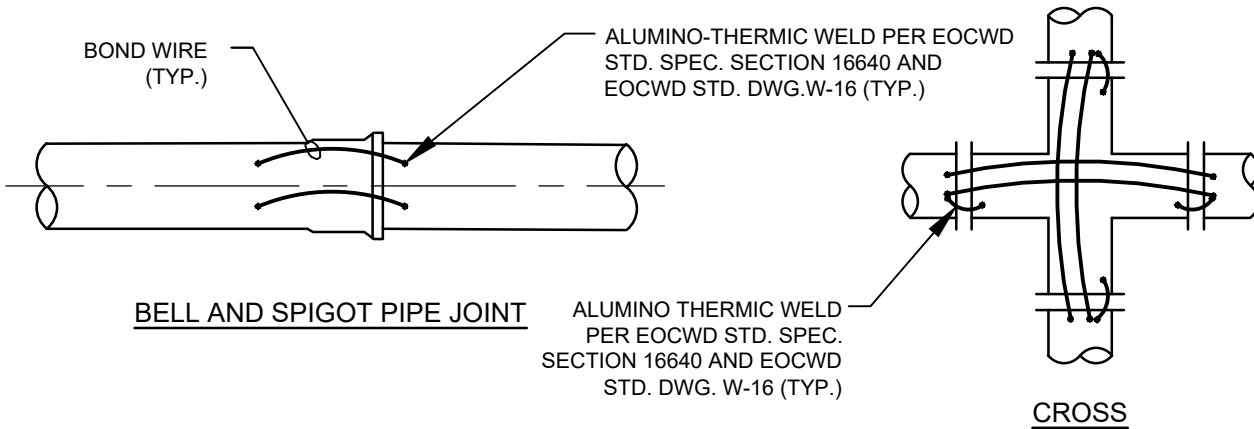

3/6/2023
\\192.168.1.50\Projects\EOCWD\EOCWD-2022-001 Water Standards Update\900 Engineering\301 CAD\Plansets\W-15.dwg

DRAFT

NO.	APPROVED	DATE

EAST ORANGE COUNTY WATER DISTRICT
ORANGE, CALIFORNIA

APPROVED BY _____

GENERAL MANAGER _____ DATE _____

DISTRICT ENGINEER _____ DATE _____

**BONDING FOR PIPE JOINTS
AND FITTINGS**

1 OF 2

NO SCALE

STANDARD DWG.

W-15

NOTES:

1. ALL WIRE WELDS SHALL BE MIN. 6" APART.
2. BOND WIRES SHALL NOT BE INSTALLED ACROSS INSULATING JOINTS.
3. COAT WELD PER EOCWD STD. SPEC. SECTION 16640.
4. THREE BOND WIRES ARE REQUIRED FOR PIPE DIAMETERS 18" OR LARGER.
5. ALL BOND WIRES SHALL BE AS SPECIFIED IN EOCWD STD. SPEC. SECTION 16640. BOND WIRES SHALL BE AWG NO. 4 STRANDED COPPER WIRE.
6. BOND WIRES AT VALVE CROSSING SHALL BE WELDED AT A DISTANCE OF 6" FROM FACE OF FLANGE.

DRAFT

3/6/2023

\\192.168.1.50\Projects\EOCWD\EOCWD-2022-001 Water Standards Update\900 Engineering\301 CAD\Plansets\W-15-2.dwg

			EAST ORANGE COUNTY WATER DISTRICT ORANGE, CALIFORNIA	BONDING FOR PIPE JOINTS AND FITTINGS 2 OF 2	NO SCALE STANDARD DWG. W-15
			APPROVED BY		
			GENERAL MANAGER _____	DATE _____	
NO.	APPROVED	DATE	DISTRICT ENGINEER _____	DATE _____	

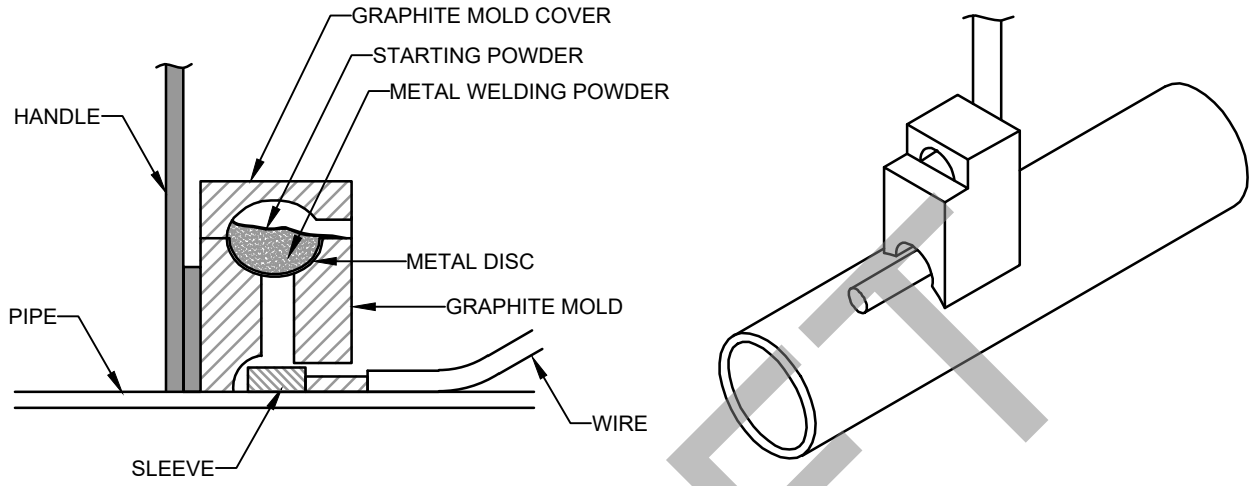

NOTES:

1. ALL WIRE WELDS SHALL BE MIN. 6" APART.
2. CAD-WELD MOLD SHOWN IS FOR HORIZONTAL SURFACES. FOR VERTICAL SURFACES SIDE WELD MOLD IS REQUIRED.

CATHODIC PROTECTION TEST STATION			
PIPE MATERIAL	WIRE SIZE	MOLD SIZE	SHOT MIX
STEEL CML&C	#8 AWG STRANDED	CAHAA-1G	CA-15
STEEL CYLINDER PIPE	#8 AWG STRANDED	CAHAA-1G	CA-15
DUCTILE IRON PIPE	#8 AWG STRANDED	CA 32X-F19	XF-19

JOINT BONDING			
PIPE MATERIAL	WIRE SIZE	MOLD SIZE	SHOT MIX
STEEL CML&C	#4 AWG STRANDED	CAHAA-1G	CA-15
STEEL CYLINDER PIPE	#4 AWG STRANDED	CAHAA-1G	CA-15
DUCTILE IRON PIPE	#4 AWG STRANDED	CA 32X-F19	XF-19

3/6/2023
 \\192.168.1.50\Projects\ECCWD\ECCWD-2022-001 Water Standards Update\900.Engineering\301 CAD\Plansets\W-16.dwg

NO.	APPROVED	DATE

EAST ORANGE COUNTY WATER DISTRICT
 ORANGE, CALIFORNIA
 APPROVED BY _____
 GENERAL MANAGER _____ DATE _____
 DISTRICT ENGINEER _____ DATE _____

ALUMINO-THERMIC (CAD)
WELDING 1 OF 2

NO SCALE
 STANDARD DWG.
W-16

3/6/2023

\\192-168-1-50\Projects\EOCWD\EOCWD-2022-001 Water Standards Update\900 Engineering\301 CAD\Plans\W-16-2.dwg

- STEP 1: REMOVE COATING OR ENCASEMENT FROM PIPE.
- STEP 2: FILE OR GRIND PIPE SURFACE TO BARE SHINY METAL (EQUIVALENT TO SSPC-10 "NEAR WHITE METAL") TO A MIN. SIZE OF AN AREA OF 3" X 3".
- STEP 3: PREHEAT THE AREA TO BE CAD-WELDED WITH A PROPANE TORCH TO REMOVE ANY SURFACE MOISTURE (DO NOT OVER HEAT).
- STEP 4: STRIP 1" OF INSULATION FROM END OF CP TEST WIRE.
- STEP 5: WRAP TEST LEAD WIRE ONCE AROUND OUTSIDE CIRCUMFERENCE OF PIPE THEN TIE WIRE INTO A "HALF HITCH" KNOT APPROXIMATELY 12" AWAY FROM CAD-WELD AREA. LEAVE 12" OR MORE OF WIRE (SLACK) BETWEEN KNOT AND CAD-WELD (THIS WILL HELP PREVENT FUTURE DAMAGE TO CAD-WELD).
- STEP 6: INSTALL APPROPRIATE CAD-WELD PROTECTIVE SLEEVE ONTO SPECIFIC AWG WIRE SIZE. (REFER TO TABLES HEREON).
- STEP 7: SELECT CORRECT CAD-WELD GRAPHITE MOLD AND APPROPRIATE WELDING POWDER FOR THE SIZE AND TYPE OF WIRE AND METALLIC PIPE THAT IS TO BE WELDED (REFER TO TABLES HEREON).
- STEP 8: INSPECT AND CLEAN THE GRAPHITE MOLD.
- STEP 9: INSERT CAD-WELD DISC IN BOTTOM OF GRAPHITE MOLD, POUR ENTIRE CONTENTS OF SHOT (ALUMINO-THERMIC WELD POWDER AND STARTER) INTO GRAPHITE MOLD.
- STEP 10: PLACE WIRE IN THE CENTER OF THE CLEANED AREA SO THAT ALL OF THE STRIPPED WIRE IS IN CONTACT WITH THE PIPE SURFACE.
- STEP 11: PLACE LOADED GRAPHITE MOLD OVER WIRE AND HOLD FIRMLY IN PLACE.
- STEP 12: POSITION YOURSELF (AND ANY OTHER PERSONNEL) AT LEAST 90° AWAY FROM IGNITION PORT OPENING.
- STEP 13: HOLD FLINT GUN AT IGNITION PORT AND IGNITE STARTING POWDER.
- STEP 14: REMOVE GRAPHITE MOLD FROM PIPE AFTER CAD-WELD COMBUSTION HAS STOPPED.
- STEP 15: REMOVE SLAG FROM WELD AREA USING A WELDING PEEN HAMMER.
- STEP 16: GRASP WIRE AND APPLY TENSION TO WIRE WHILE STRIKING WELD WITH A 2 LBS. HAMMER TO CHECK SOUNDNESS OF WELD. (BE CAUTIOUS OF DAMAGE TO INTERIOR OF PIPE LINING.)
- STEP 17: COAT WIRE, CAD-WELD, AND EXPOSED PIPE SURFACE WITH APPROVED CONNECTION COATING PER EOCWD STD. SPEC. SECTION 16640.
- STEP 18: REPLACE PIPE COATING AND PLASTIC WRAP OR TAPE IF REQUIRED.

			EAST ORANGE COUNTY WATER DISTRICT ORANGE, CALIFORNIA		ALUMINO-THERMIC (CAD) WELDING 2 OF 2	NO SCALE	
			APPROVED BY			STANDARD DWG.	
			GENERAL MANAGER _____ DATE _____			W-16	
			DISTRICT ENGINEER _____ DATE _____				
NO.	APPROVED	DATE					

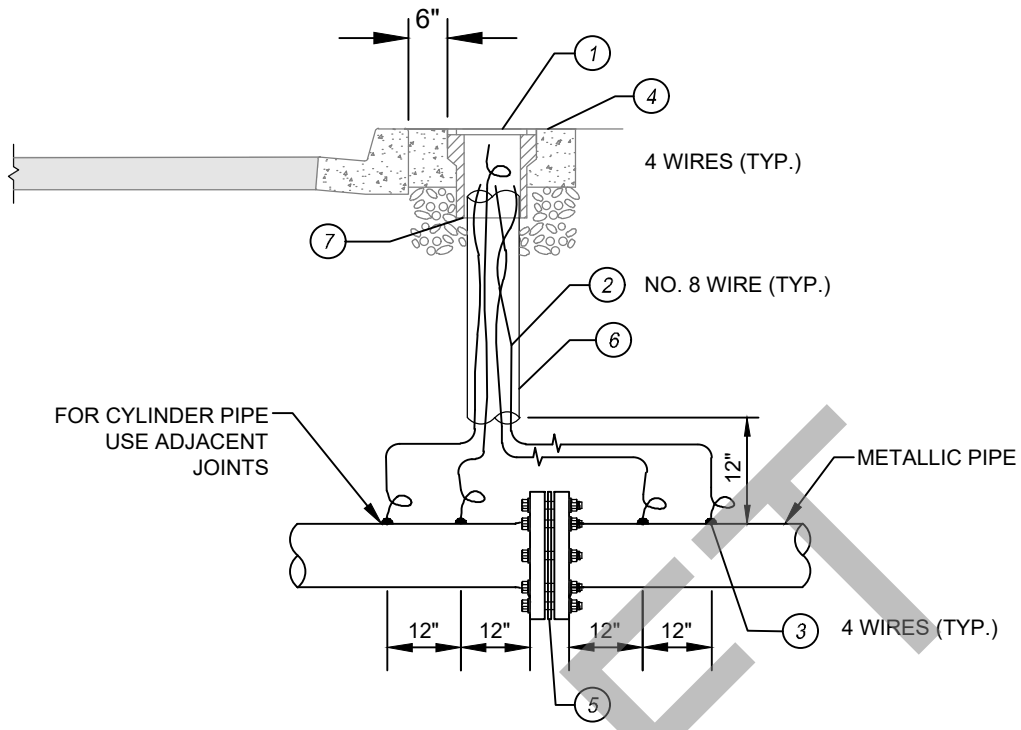

LEGEND LIST OF MATERIALS

ITEM	MATERIALS
①	10" CAST IRON TEST BOX AND FRAME
②	NO. 8 STRANDED COPPER WIRE WITH BLACK INSULATION PER EOCWD STD. SPEC. SECTION 16640. COIL BOTH ENDS PER NOTE 4.
③	ALUMINO-THERMIC WELD PER EOCWD STD. SPEC. SECTION 16640 AND EOCWD STD. DWG. CP-8 AND CP-9 (FOR METALLIC PIPE ONLY).
④	6" THICK CLASS B CONCRETE COLLAR
⑤	INSULATING FLANGE KIT
⑥	2" SCH 40 PVC CONDUIT WITH LONG SWEEP ELBOWS FROM PIPE TO TEST BOX.
⑦	CAP CONDUIT END WITH DUCT SEAL, GARDNER BENDER DS-110N, OR EQUAL.

NOTES:

- FOR TEST STATIONS INSTALLED IN UNPAVED AREAS, A UTILITY MARKER SHALL BE INSTALLED ADJACENT TO TEST STATION.
- THE TEST STATION SHALL EXTEND PERPENDICULAR TO THE CENTERLINE OF THE STREET FROM THE WATER MAIN TO THE TEST STATION BOX.
- THE TEST BOX SHALL BE SET BEHIND SIDEWALK WHERE SIDEWALK IS ADJACENT TO CURB OR IN PARKWAY BETWEEN CURB AND SIDEWALK.
- PROVIDE 36" OF COILED SLACK IN EACH WIRE AT EACH END (I.E. AT PIPE AND AT BOX). PUT THE SLACK AT THE BOX END INSIDE THE BOX.

3/6/2023
 \\192.168.1.50\Projects\EOCWD\EOCWD-2022-001 Water Standards Update\900 Engineering\301 CAD\Plansets\W-17.dwg

		EAST ORANGE COUNTY WATER DISTRICT ORANGE, CALIFORNIA		INSULATOR TEST STATION	NO SCALE	
		APPROVED BY			STANDARD DWG.	
		GENERAL MANAGER _____ DATE _____			W-17	
		DISTRICT ENGINEER _____ DATE _____				
NO.	APPROVED	DATE				

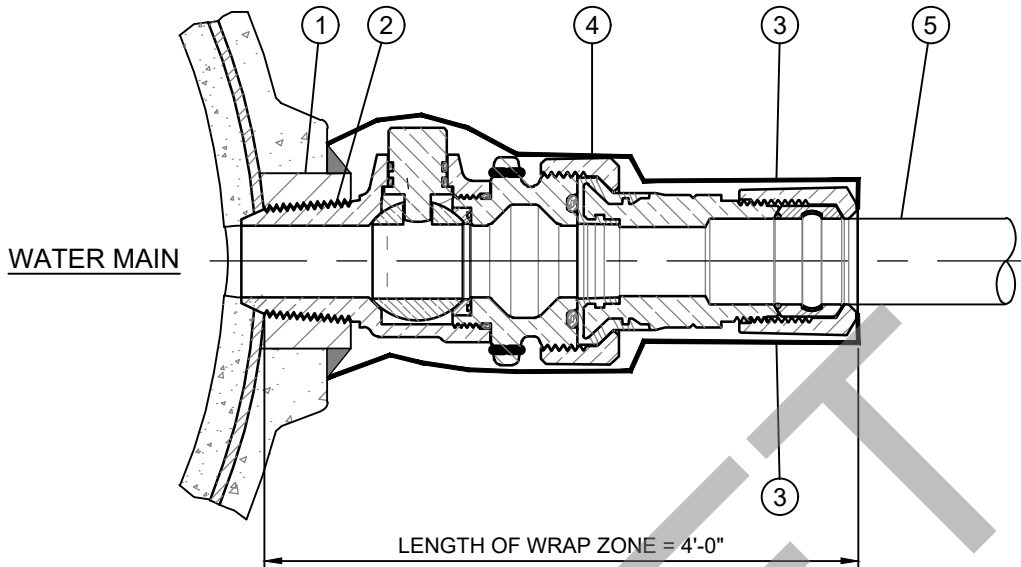

LEGEND LIST OF MATERIALS

<u>ITEM</u>	<u>MATERIALS</u>
①	COUPLING (EXTRA HEAVY CARBON STEEL 3,000 LBS. RATING)
②	INSULATING CORPORATION BALL VALVE, MUELLER N03008N
③	ADHESIVE TAPE (SEE NOTE 2.)
④	ADAPTER (WHEN REQUIRED, SEE NOTE 1.)
⑤	SERVICE TUBING

NOTES:

- DIELECTRIC CONNECTIONS SHALL BE REQUIRED ON ALL AIR AND VACUUM VALVE ASSEMBLIES, MANUAL AIR RELEASE ASSEMBLIES AND WATER SERVICE ASSEMBLIES WHERE COPPER OR BRASS PIPE CONNECTIONS ARE MADE TO STEEL MAINS.
- TYPICAL WRAP - USE DOUBLE WRAP OF 10 MIL 2" WIDE ADHESIVE TAPE. WRAP CORPORATION STOP OR VALVE IN OPEN POSITION, UNLESS OTHERWISE DIRECTED.
- REFER TO SPEC SECTION 02667 FOR CONNECTION OF COUPLING TO EXISTING STEEL PIPE CYLINDER.
- REPAIR MORTAR COATED STEEL MAIN PER SPEC SECTION 02667.

3/6/2023

\\192-168.1.50\Projects\ECCWD\ECCWD-2022-001 Water Standards Update\900 Engineering\301 CAD\Plansets\W-18.dwg

			EAST ORANGE COUNTY WATER DISTRICT ORANGE, CALIFORNIA	DIELECTRIC CONNECTION TO METALLIC MAIN	NO SCALE
			APPROVED BY		STANDARD DWG.
			GENERAL MANAGER _____ DATE _____		W-18
NO.	APPROVED	DATE	DISTRICT ENGINEER _____ DATE _____		

3/6/2023

\\192-168-1-50\Projects\EOCWD\EOCWD-2022-001 Water Standards Update\900-Engineering\301 CAD\Plansets\W-19.dwg

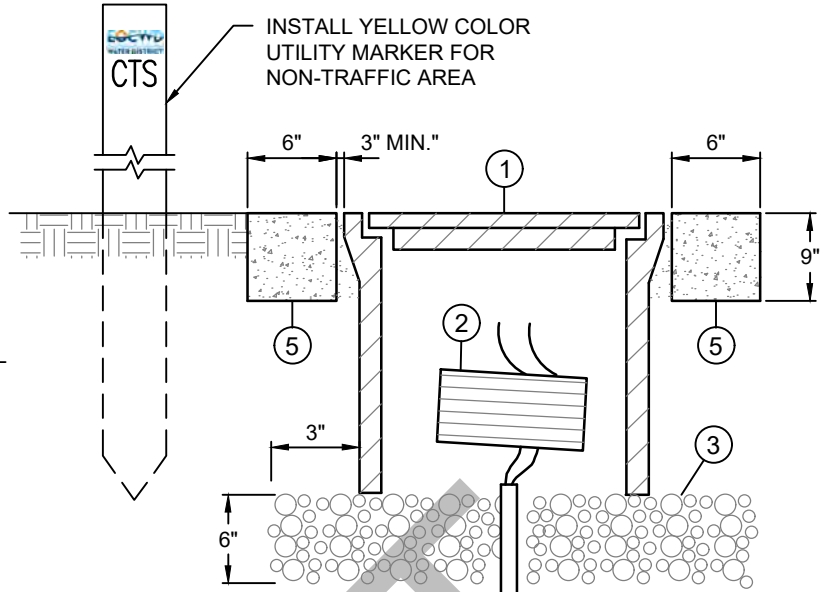
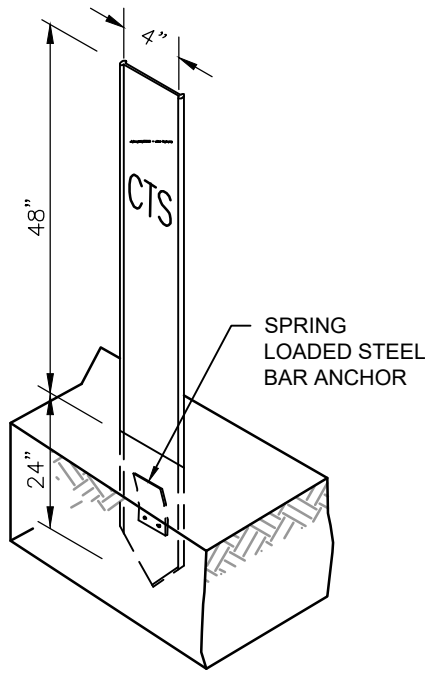

UTILITY MARKER

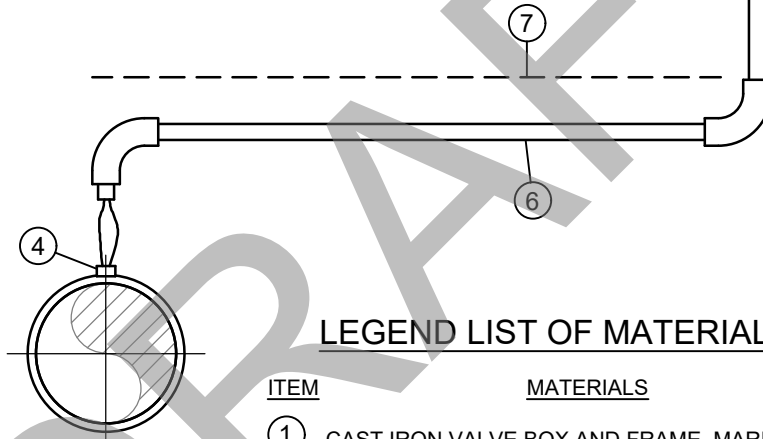

LEGEND LIST OF MATERIALS

ITEM	MATERIALS
①	CAST IRON VALVE BOX AND FRAME, MARK "CPTS" FOR TEST STATION.
②	TEST WIRE (REFER TO STANDARD DRAWINGS W-14 AND W-17 FOR SPECIFICS)
③	3/4" CRUSHED ROCK
④	CONNECTION (REFER TO STANDARD DRAWINGS W-14 AND W-17 FOR SPECIFICS)
⑤	CLASS B CONCRETE. REINFORCED WITH W.W.F. 1.6 x 1.6 IN UNPAVED AND TURF CONDITIONS.
⑥	2" SCH 40 PVC CONDUIT WITH LONG ELBOWS FROM PIPE TO TEST BOX.
⑦	RED WARNING TAPE WITH BLACK LETTERING WITH THE WORDING "CAUTION CATHODIC PROTECTION CABLE BURIED BELOW".

NOTES:

1. PROVIDE MINIMUM 36" EXTRA WIRE INSIDE THE BOX.
2. BACKFILL PER STANDARD DRAWING W-10.

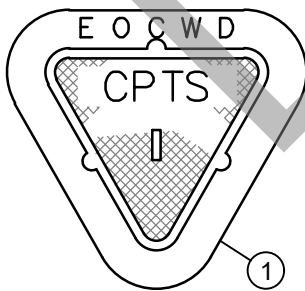

COVER

			EAST ORANGE COUNTY WATER DISTRICT ORANGE, CALIFORNIA		CATHODIC PROTECTION TEST POINT STATION FOR TRAFFIC CONDITIONS		NO SCALE	
			APPROVED BY				STANDARD DWG.	
			GENERAL MANAGER		DATE		W-19	
			DISTRICT ENGINEER		DATE			
NO.	APPROVED	DATE						

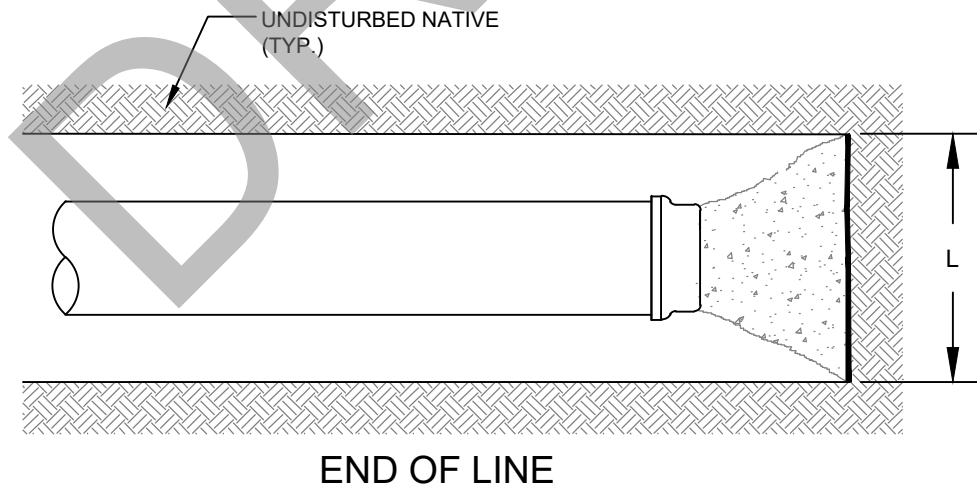
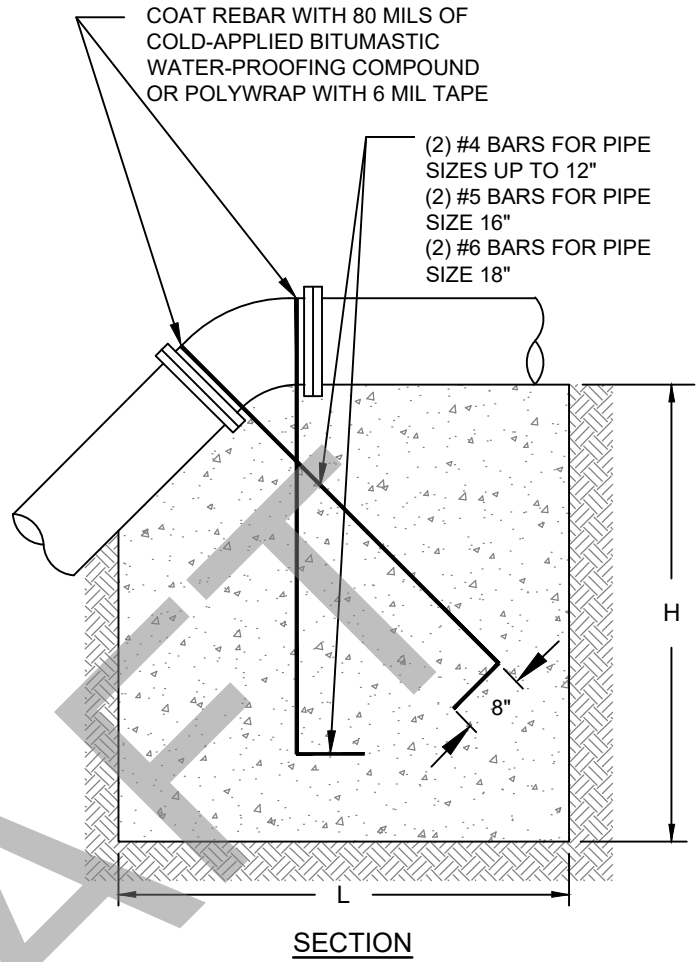
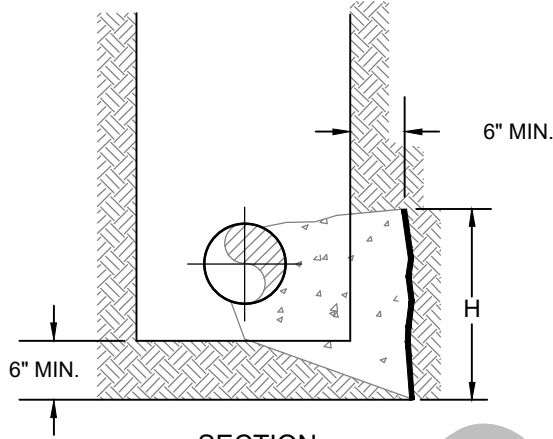
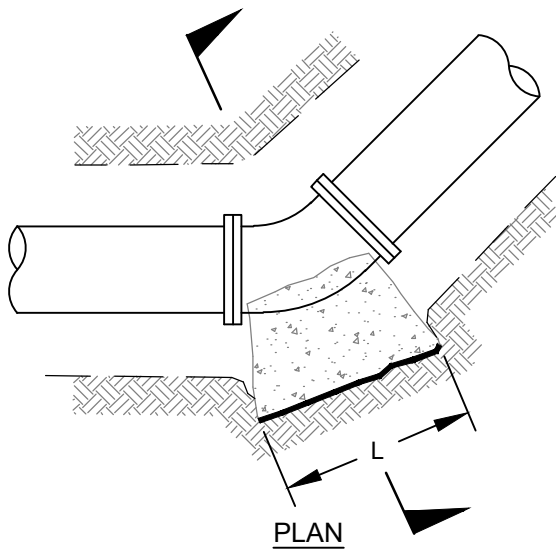

NOTE:

1. SEE SHEET 6 OF 6 FOR ADDITIONAL NOTES.

3/6/2023

\\192.168.1.50\Projects\ECCWD\ECCWD-2022-001 Water Standards Update\900 Engineering\301 CAD\Plans\W-20.dwg

NO.	APPROVED	DATE

EAST ORANGE COUNTY WATER DISTRICT ORANGE, CALIFORNIA	
APPROVED BY	
GENERAL MANAGER	DATE
DISTRICT ENGINEER	DATE

THRUST BLOCK
1 OF 6

NO SCALE
STANDARD DWG.
W-20

VERTICAL BEND ANCHOR BLOCK *						
PIPE SIZE (IN)	22 1/2° BEND L, H, W (IN)	VOLUME (YD ³)	THRUST (LBS)	45° BEND L, H, W (IN)	VOLUME (YD ³)	THRUST (LBS)
4	26	0.4	1,104	32	0.7	2,165
6	34	0.8	2,483	42	1.6	4,871
8	41	1.5	4,414	51	2.8	8,659
10	47	2.2	6,897	59	4.4	13,529
12	53	3.2	9,932	67	6.4	19,482

HORIZONTAL BEND THRUST BLOCK								
PIPE SIZE (IN)	11 1/4° BEND				22 1/2° BEND			
	L (IN)	H (IN)	AREA (IN ²)	THRUST (LBS)	L (IN)	H (IN)	AREA (IN ²)	THRUST (LBS)
4	12	6	72	554	16	8	128	1,104
6	17	9	153	1,248	24	12	288	2,483
8	23	12	276	2,218	32	16	512	4,414
10	29	15	435	3,465	40	20	800	6,897
12	34	17	578	4,990	48	24	1,152	9,932

HORIZONTAL BEND THRUST BLOCK								
PIPE SIZE (IN)	45° BEND				90° BEND			
	L (IN)	H (IN)	AREA (IN ²)	THRUST (LBS)	L (IN)	H (IN)	AREA (IN ²)	THRUST (LBS)
4	23	12	276	2,165	31	16	496	4,000
6	34	17	578	4,871	46	23	1,058	9,000
8	45	23	1,035	8,659	61	31	1,891	15,999
10	56	28	1,568	13,529	76	38	2,888	24,999
12	67	34	2,278	19,482	92	46	4,232	35,999

HORIZONTAL BEND THRUST BLOCK				
PIPE SIZE (IN)	END OF LINE			
	L (IN)	H (IN)	AREA (IN ²)	THRUST (LBS)
4	26	13	338	2,828
6	39	20	780	6,364
8	52	26	1,352	11,313
10	64	32	2,048	17,677
12	77	39	3,003	25,455

* FOR DUCTILE IRON PIPE, ALL VERTICAL BENDS SHALL BE MECHANICALLY RESTRAINED. SEE NOTE 14 ON SHEET 6 OF 6.

		EAST ORANGE COUNTY WATER DISTRICT ORANGE, CALIFORNIA		THRUST BLOCK 2 OF 6		NO SCALE	
		APPROVED BY _____				STANDARD DWG.	
		GENERAL MANAGER _____ DATE _____				W-20	
NO.	APPROVED	DATE	DISTRICT ENGINEER _____	DATE _____			

3/6/2023

\\192.168.1.50\Projects\EOC\DWG\ECOWD-2022-001 Water Standards Update\900 Engineering\301 CAD\Plansets\W-20-2.dwg

3/6/2023

\\192-168-1-50\Projects\ECCWD\ECCWD-2022-001 Water Standards Update\900 Engineering\301 CAD\Plans\W-20-3.dwg

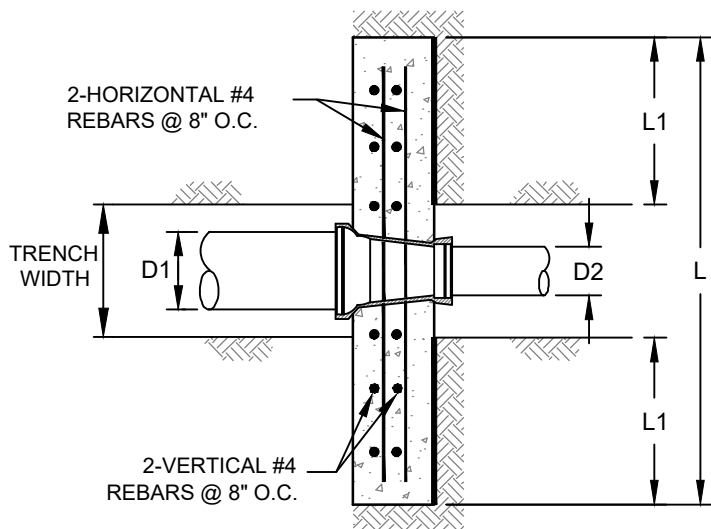

PLAN

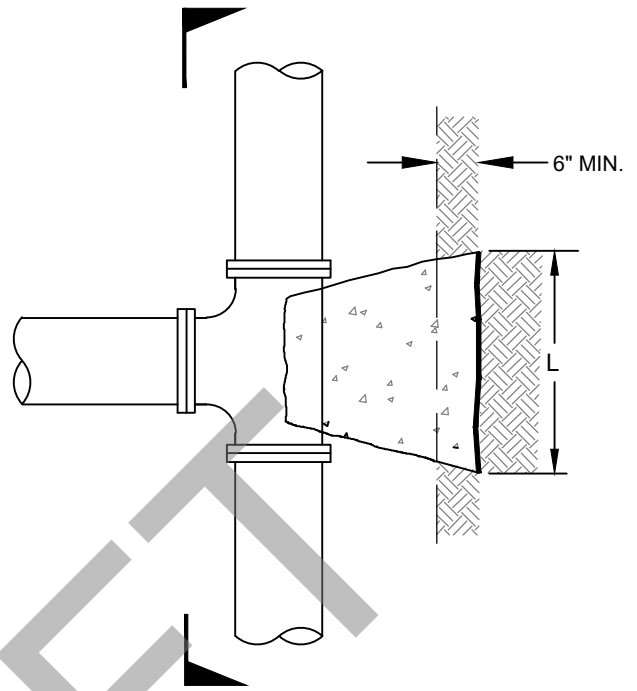

PLAN

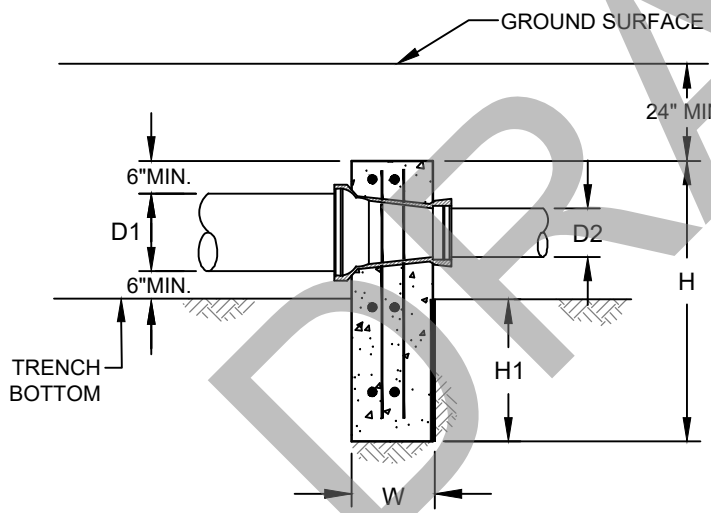

SECTION
REDUCER

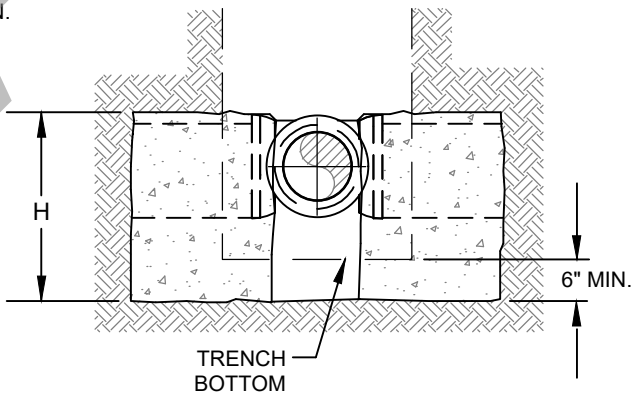

SECTION
TEE

NOTE:
1. SEE SHEET 6 OF 6 FOR ADDITIONAL NOTES.

NO.	APPROVED	DATE

EAST ORANGE COUNTY WATER DISTRICT
ORANGE, CALIFORNIA
APPROVED BY
GENERAL MANAGER _____ DATE _____
DISTRICT ENGINEER _____ DATE _____

THRUST BLOCK
3 OF 6

NO SCALE
STANDARD DWG.
W-20

PIPE SIZE (IN)	TEE			
	L (IN)	H (IN)	AREA (IN ²)	THRUST (LBS)
4	26	13	338	2,828
6	39	20	780	6,364
8	52	26	1,352	11,313
10	64	32	2,048	17,677
12	77	39	3,003	25,455

D1xD2 (IN)	REDUCER								
	TRENCH WIDTH* (IN)	L (IN)	H (IN)	H1 (IN)	L1 (IN)	W (IN)	TOTAL AREA INCLD. TRENCH (IN ²)	MIN. BEARING AREA** (IN ²)	THRUST (LBS)
12X10	30	52	34	8	11	12	1,768	954	7,778
12X8	30	62	41	15	16	12	2,542	1,762	14,142
12X6	30	68	45	19	19	12	3,060	2,280	19,091
12X4	30	72	48	22	21	10	3,456	2,676	22,627
10X8	30	48	32	8	9	10	1,536	816	6,364
10X6	30	56	37	13	13	10	2,072	1,352	11,313
10X4	30	62	41	17	16	10	2,542	1,822	14,849
8X6	24	42	28	6	9	10	1,176	648	4,950
8X4	24	48	32	10	12	8	1,536	1,008	8,485
6X4	24	38	25	5	7	8	950	470	3,535

* IF A DIFFERENT TRENCH WIDTH IS USED, THE THRUST BLOCK SHALL MAINTAIN THE MIN. BEARING AREA SHOWN.

** BEARING AREA REQUIRED ON UNDISTURBED SOIL OUTSIDE OF TRENCH.

NOTE:

1. SEE SHEET 6 OF 6 FOR ADDITIONAL NOTES.

		EAST ORANGE COUNTY WATER DISTRICT ORANGE, CALIFORNIA		THRUST BLOCK 4 OF 6		NO SCALE	
		APPROVED BY				STANDARD DWG.	
		GENERAL MANAGER _____ DATE _____				W-20	
NO. APPROVED		DATE		DISTRICT ENGINEER _____ DATE _____			

3/6/2023

\\192-168-1-50\Projects\ECCWD\ECCWD-2022-001 Water Standards Update\900 Engineering\301 CAD\Plansets\W-20-5.dwg

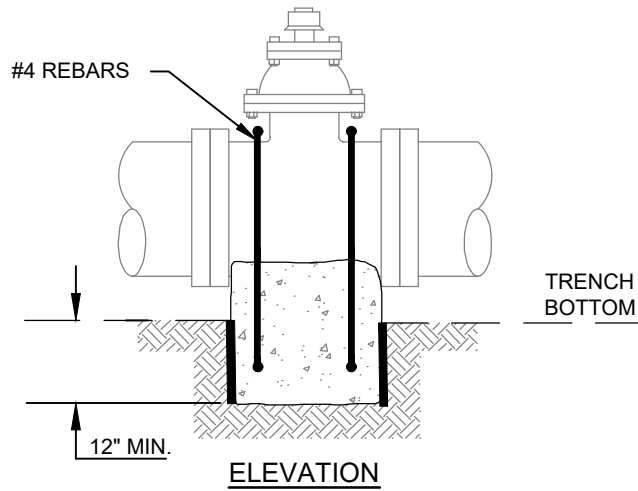

PIPE SIZE (IN)	L (FT)	H (FT)
4	1	1
6	1.5	1.5
8	2	2
10	2	3
12	2	4

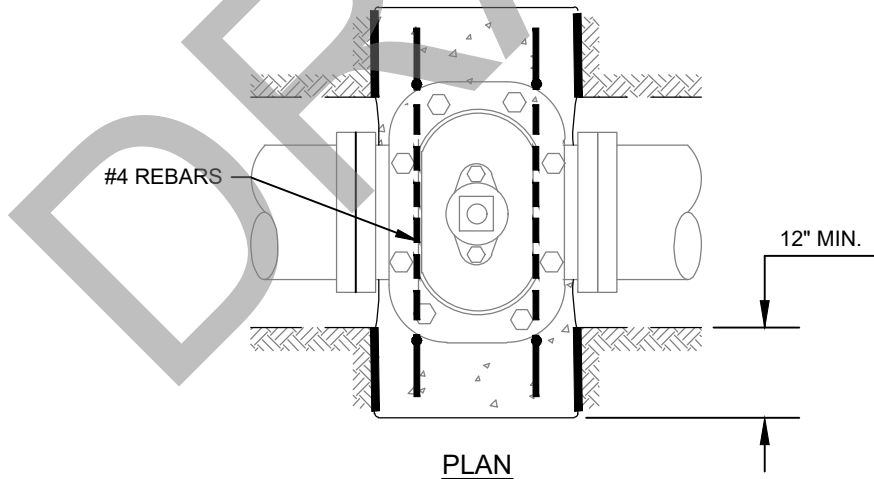
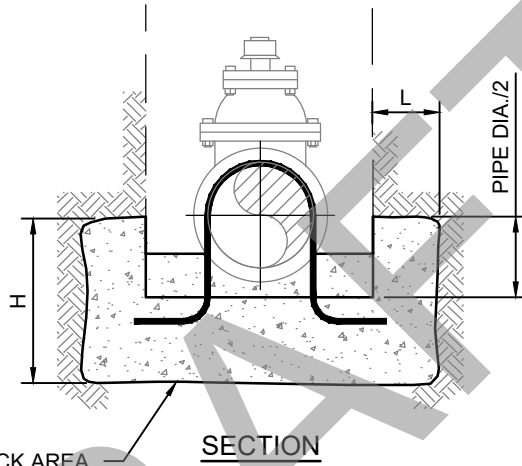

NOTE:

1. SEE SHEET 6 OF 6 FOR ADDITIONAL NOTES. SUBMIT DESIGN FOR ANY CONDITION THAT VARIES FROM NOTE 1 ON PAGE 6.
2. GATE VALVES THRUST BLOCK SHALL BE INSTALLED IN LOCATIONS IN ABSENCE OF RESTRAINED JOINTS AND UPON APPROVAL BY THE DISTRICT.

IN LINE GATE VALVES

			EAST ORANGE COUNTY WATER DISTRICT ORANGE, CALIFORNIA		NO SCALE	
			APPROVED BY			
			GENERAL MANAGER _____ DATE _____		STANDARD DWG. W-20	
			DISTRICT ENGINEER _____ DATE _____			
NO.	APPROVED	DATE	THRUST BLOCK 5 OF 6			

NOTES:

1. THRUST BLOCK BEARING AREA BASED ON ALLOWABLE SOIL BEARING VALUE OF 1500 PSF PRESSURE, 225 PSI LINE PRESSURE WITH 3'-0" COVER MIN., AND A MIN. SAFETY FACTOR OF 1.2.
 FOR BEARING = 1000 PSF, 1.5 X AREA SHOWN
 FOR BEARING = 500 PSF, 3.0 X AREA SHOWN
2. ALL THRUST BLOCKS SHALL BE PORTLAND CEMENT CONCRETE MIX 560-C-3250 AND PLACED AGAINST UNDISTURBED SOIL.
3. THRUST BLOCKS ON REDUCERS SHALL BE KEYED INTO THE TRENCH BOTTOM AS SHOWN.
4. CONCRETE SHALL NOT EXTEND ONTO FLANGE OR ADJOINING PIPE.
5. DO NOT COVER FITTING BOLTS WITH CONCRETE.
6. WHEN VALVES ARE FLANGED TO FITTINGS, AVOID PLACING CONCRETE ON ANY PART OF THE VALVE BONNET OR VALVE OPERATOR.
7. COAT REBAR WITH 80 MILS OF COLD-APPLIED BITUMASTIC WATER-PROOFING COMPOUND. WRAP EXTERIOR OF VALVE, ACTUATOR AND REBAR WITH 8 MIL POLYETHYLENE SHEETING AND TAPE PER EOCWD SPEC. SECTION 15100.
8. MIN. CONCRETE COVER OVER REBAR SHALL BE 3".
9. NO CONCRETE SHALL BE Poured ON VALVE OR PIPE JOINT.
10. YIELD STRENGTH OF STEEL BARS IS ASSUMED TO BE 36 KSI.
11. FOR PIPELINES LARGER THAN 12" IN DIA., THE ENGINEER SHALL CALCULATE THRUST BLOCK SIZE BASED ON PROJECT SPECIFIC SOIL CONDITIONS AND SHALL SUBMIT THE CALCULATIONS TO THE DISTRICT FOR APPROVAL.
12. MECHANICAL THRUST RESTRAINTS SHALL BE PROVIDED IN LIEU OF THRUST OR ANCHOR BLOCKS IF THE BEARING FACE OF THE THRUST OR ANCHOR BLOCK MAY BE DISTURBED AT ANY POINT AFTER CONSTRUCTION OR DURING CONSTRUCTION OF OTHER FACILITIES.
13. WHERE MECHANICAL THRUST RESTRAINTS ARE PROVIDED, THE ENGINEER SHALL CALCULATE THE REQUIRED LENGTH OF THRUST RESTRAINT ALONG THE PIPELINE ALIGNMENT AND SHALL SUBMIT THE CALCULATIONS TO THE DISTRICT FOR APPROVAL.
14. DUCTILE IRON PIPE JOINT FITTINGS SHALL BE MECHANICALLY RESTRAINED AT ALL VERTICAL BENDS. VERTICAL BEND ANCHOR BLOCKS SHALL ONLY BE PROVIDED WHERE APPROVED BY DISTRICT.

3/6/2023

\\192.168.1.50\Projects\EOCWD\EOCWD-2022-001 Water Standards Update\900 Engineering\301 CAD\Plansets\W-20-6.dwg

			EAST ORANGE COUNTY WATER DISTRICT ORANGE, CALIFORNIA	THRUST BLOCK 6 OF 6	NO SCALE
			APPROVED BY		STANDARD DWG.
			GENERAL MANAGER _____ DATE _____		W-20
NO.	APPROVED	DATE	DISTRICT ENGINEER _____ DATE _____		

3/6/2023

\\192-168-1-50\Projects\ECCWD\ECCWD-2022-001 Water Standards Update\900 Engineering\301 CAD\Plans\W-21.dwg

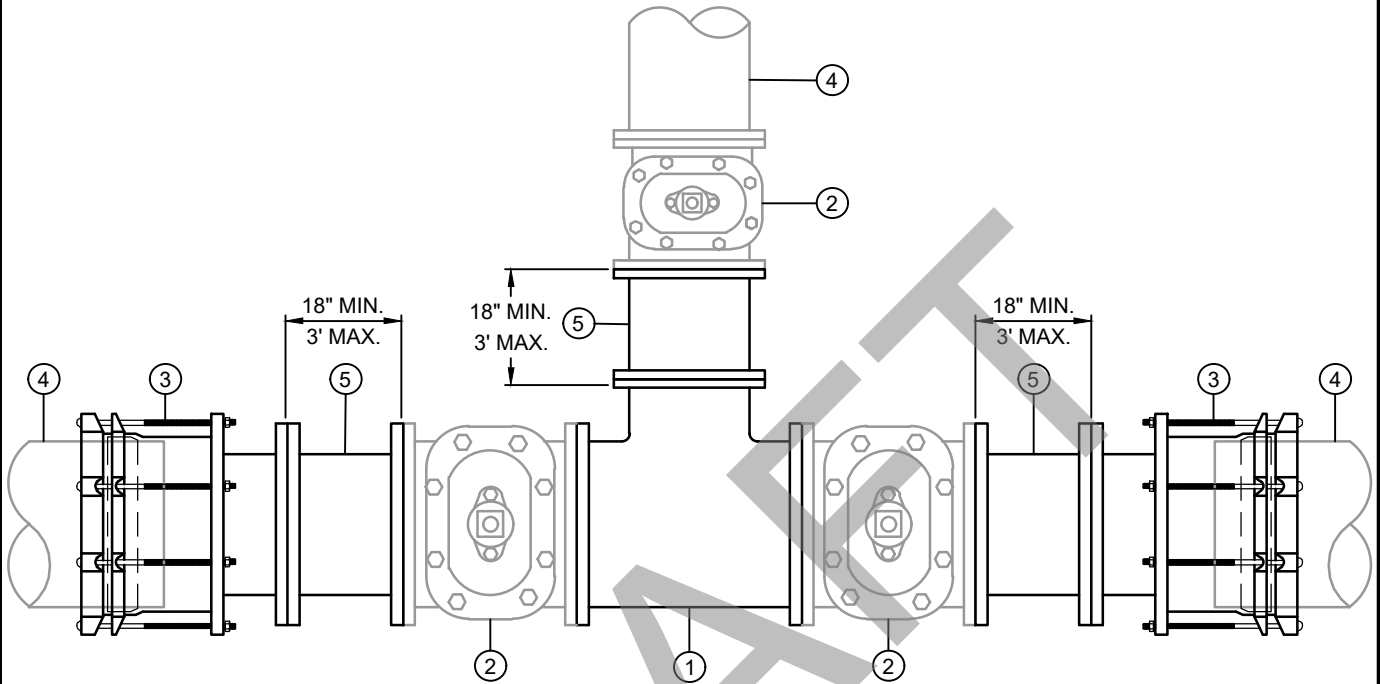

LEGEND LIST OF MATERIALS

ITEM	MATERIALS
①	D.I. TEE, FLG x FLG
②	RESILIENT WEDGE GATE VALVE FLG x FLG
③	D.I. FLANGED COUPLING ADAPTER WITH 316 STAINLESS STEEL NUTS, BOLTS AND WASHERS.
④	EXISTING PVC PIPE
⑤	D.I. SPOOL PIECE

NO.	APPROVED	DATE

EAST ORANGE COUNTY WATER DISTRICT ORANGE, CALIFORNIA	
APPROVED BY	
GENERAL MANAGER	DATE
DISTRICT ENGINEER	DATE

CUT-IN TEE FOR PVC
1 OF 3

NO SCALE
STANDARD DWG.
W-21

3/6/2023

\\192-168-1-50\Projects\ECCWD\ECCWD-2022-001 Water Standards Update\900 Engineering\301 CAD\Plans\W-21-2.dwg

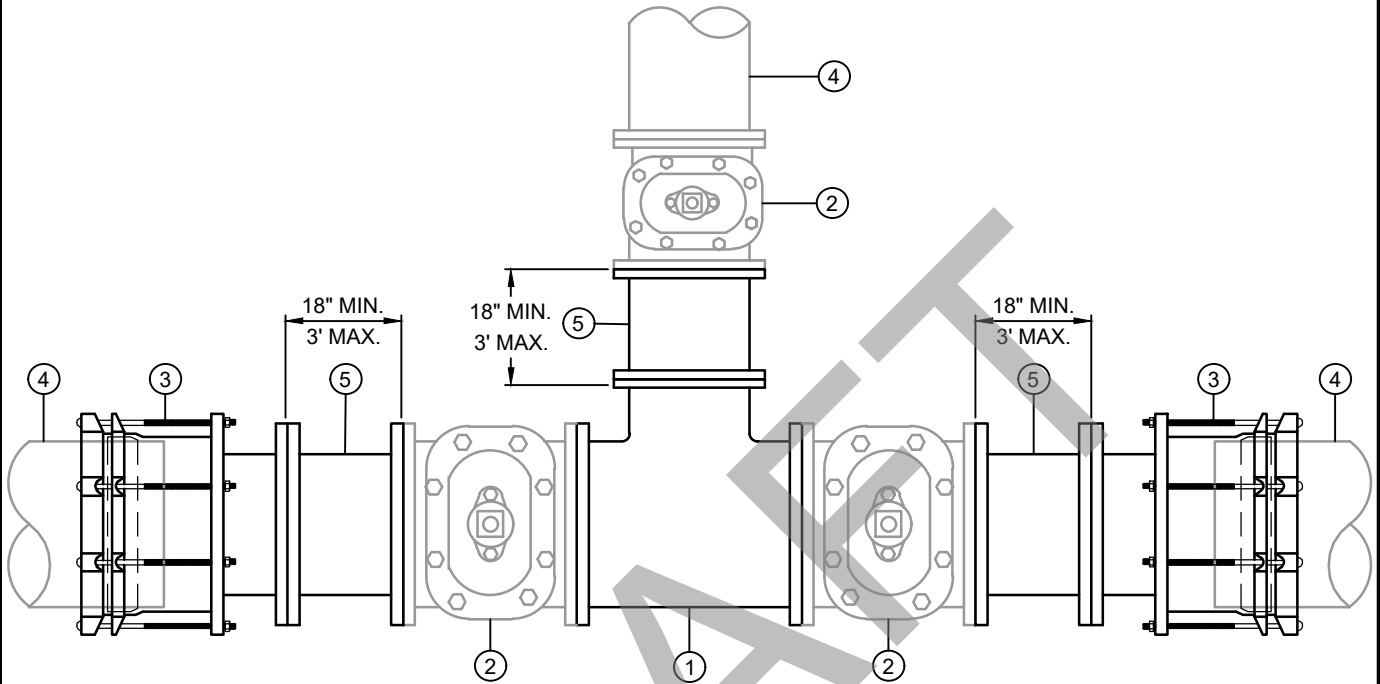

LEGEND LIST OF MATERIALS

ITEM	MATERIALS
①	D.I. TEE, FLG x FLG
②	RESILIENT WEDGE GATE VALVE FLG x FLG
③	D.I. FLANGED COUPLING ADAPTER WITH 316 STAINLESS STEEL NUTS, BOLTS AND WASHERS.
④	EXISTING DIP
⑤	D.I. SPOOL PIECE

NO.	APPROVED	DATE

EAST ORANGE COUNTY WATER DISTRICT ORANGE, CALIFORNIA	
APPROVED BY	
GENERAL MANAGER	DATE
DISTRICT ENGINEER	DATE

CUT-IN TEE FOR DIP
2 OF 3

NO SCALE
STANDARD DWG.
W-21

3/6/2023

\\192-168-1-50\Projects\ECCWD\ECCWD-2022-001 Water Standards Update\900 Engineering\301 CAD\Plans\W-21-3.dwg

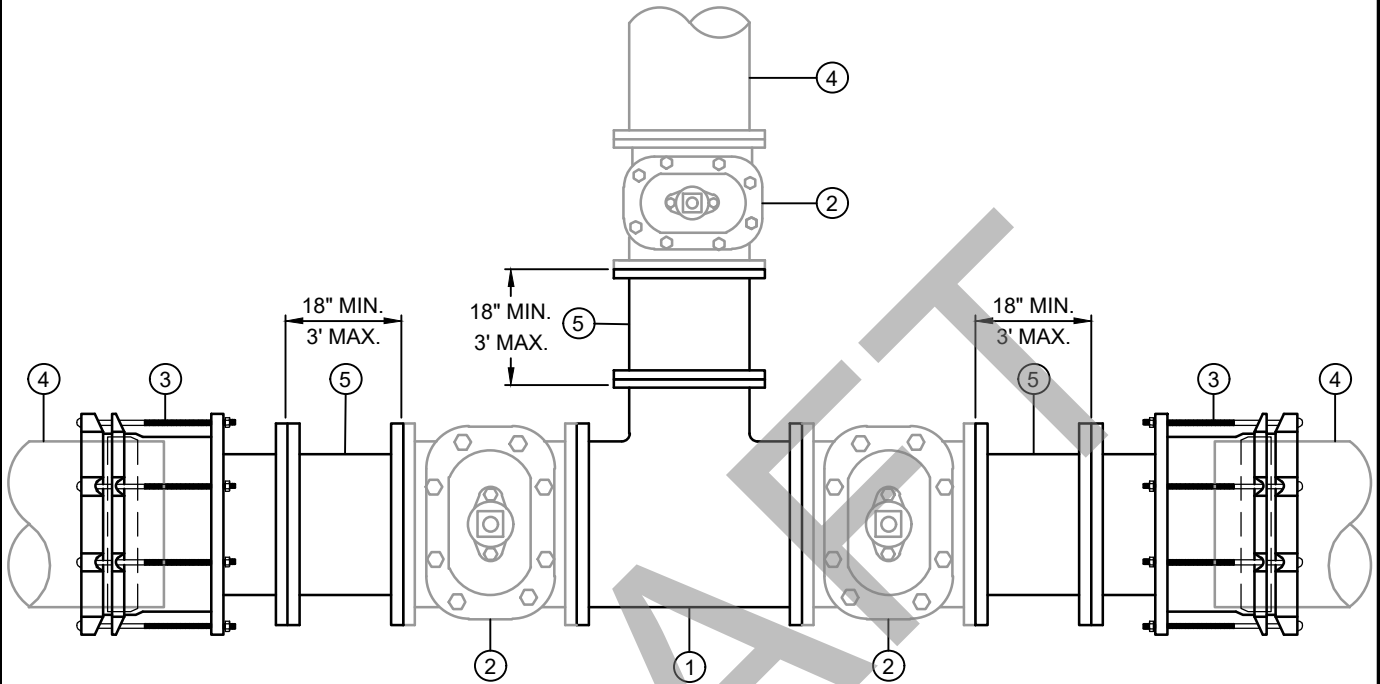

LEGEND LIST OF MATERIALS

ITEM	MATERIALS
①	D.I. TEE, FLG x FLG
②	RESILIENT WEDGE GATE VALVE FLG x FLG
③	D.I. FLANGED COUPLING ADAPTER WITH 316 STAINLESS STEEL NUTS, BOLTS AND WASHERS.
④	EXISTING ACP
⑤	D.I. SPOOL PIECE

NOTES:

- CUT ANY MACHINE-END OFF ACP TO EXISTING ROUGH BARREL.

		EAST ORANGE COUNTY WATER DISTRICT ORANGE, CALIFORNIA		CUT-IN TEE FOR ACP 3 OF 3		NO SCALE	
		APPROVED BY				STANDARD DWG.	
		GENERAL MANAGER		DATE		W-21	
NO.		APPROVED		DATE			
		DISTRICT ENGINEER		DATE			

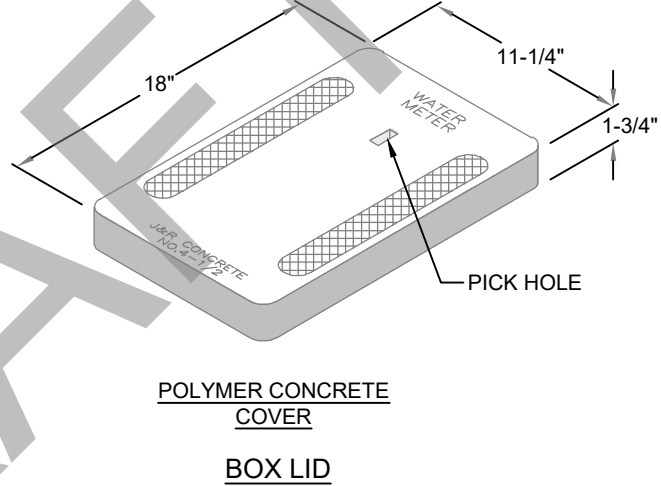
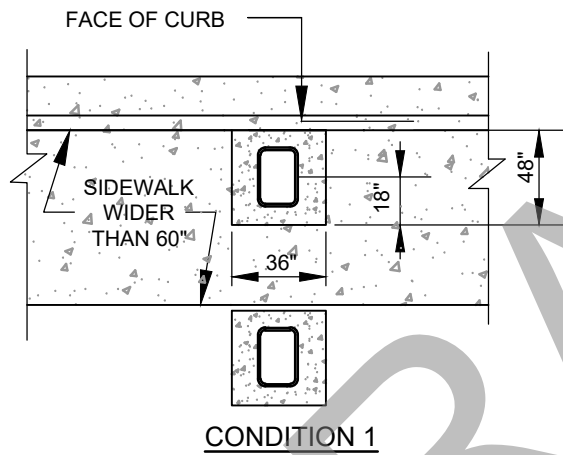
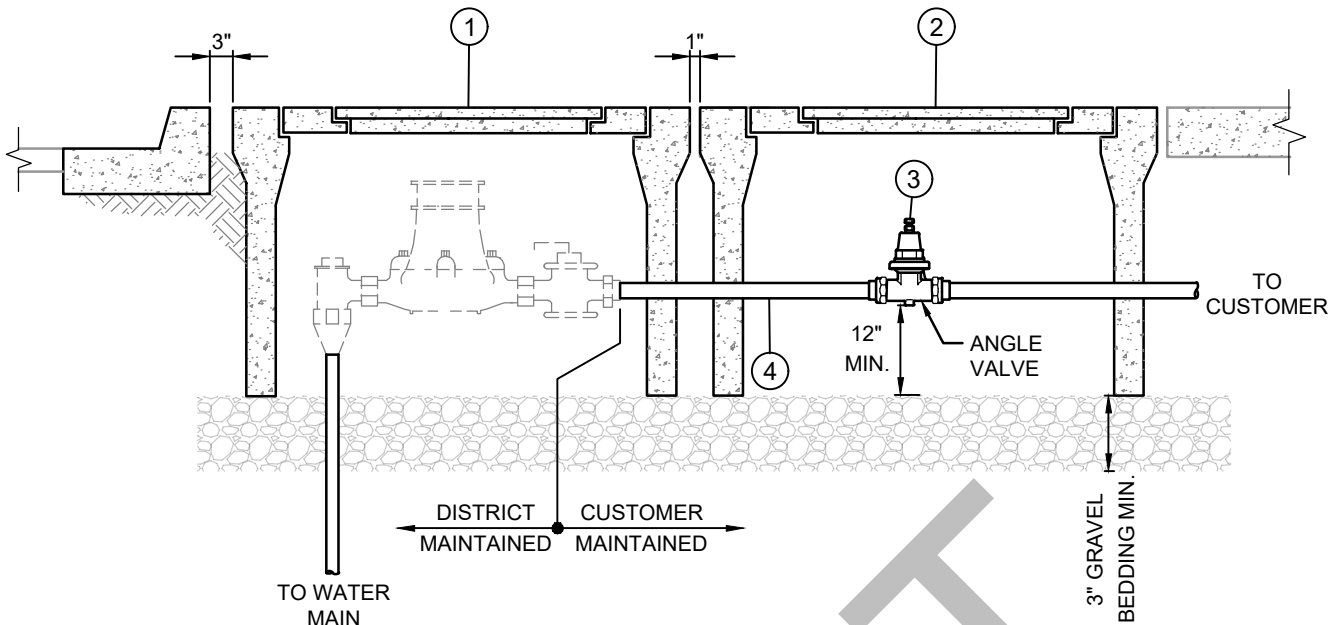

LEGEND LIST OF MATERIALS

- | ITEM | MATERIALS |
|------|------------------------------------------------------------------------------------------------------|
| ① | METER SERVICE ASSEMBLY, REFER TO STANDARD DRAWINGS W-1 AND W-2 FOR SPECIFIC APPLICATIONS. |
| ② | 12" X 20" POLYMER CONCRETE METER BOX AND POLYMER CONCRETE COVER, J&R CONCRETE NO. P-W4-1/2 OR EQUAL. |
| ③ | BRONZE PRESSURE REDUCING VALVE, (ZURN WILKINS 70XL (SC) OR EQUAL) SIZE TO MATCH PIPE. |
| ④ | COPPER TUBING |

NOTES:

- REFER TO STANDARD DRAWINGS W-1 AND W-2 FOR SERVICE SIZE AND DETAILS.
- REFER TO STANDARD DRAWING W-3 FOR LOCATION OF METERS.
- ALL PRESSURE REDUCING ASSEMBLY BOX LOCATIONS SHALL BE VERIFIED BY EOCWD.

3/6/2023

\\192.168.1.50\Projects\EOCWD\EOCWD-2022-001 Water Standards Update\900 Engineering\301 CAD\Plans\W-22.dwg

		EAST ORANGE COUNTY WATER DISTRICT ORANGE, CALIFORNIA		CUSTOMER PRESSURE REDUCING ASSEMBLY	NO SCALE
		APPROVED BY			
		GENERAL MANAGER _____ DATE _____		(FOR PRESSURES 80 PSI AND MORE)	
NO.	APPROVED	DATE	DISTRICT ENGINEER _____ DATE _____		

3/6/2023

\\192.168.1.50\Projects\ECCWD\ECCWD-2022-001 Water Standards Update\900 Engineering\301 CAD\Plansets\W-23.dwg

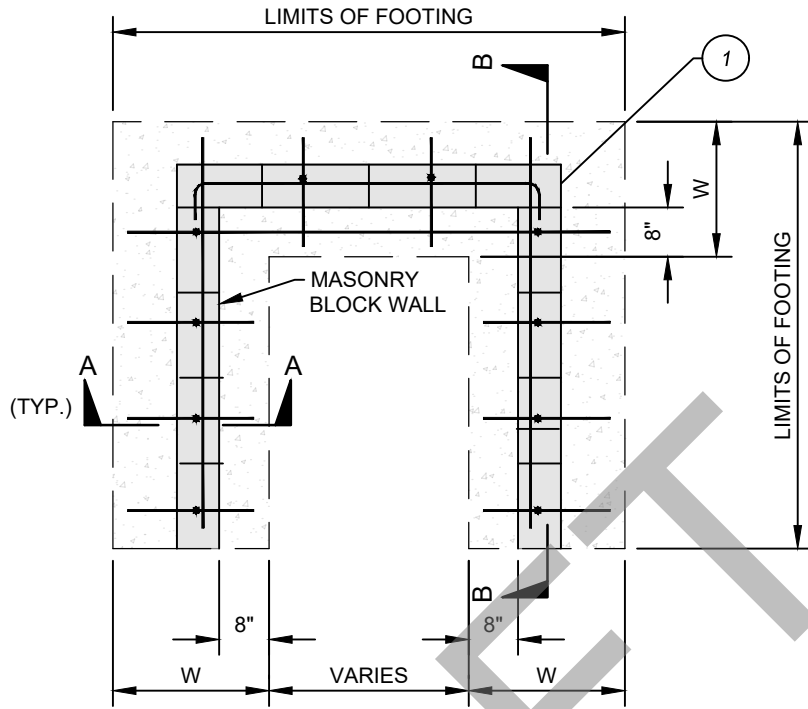

PLAN

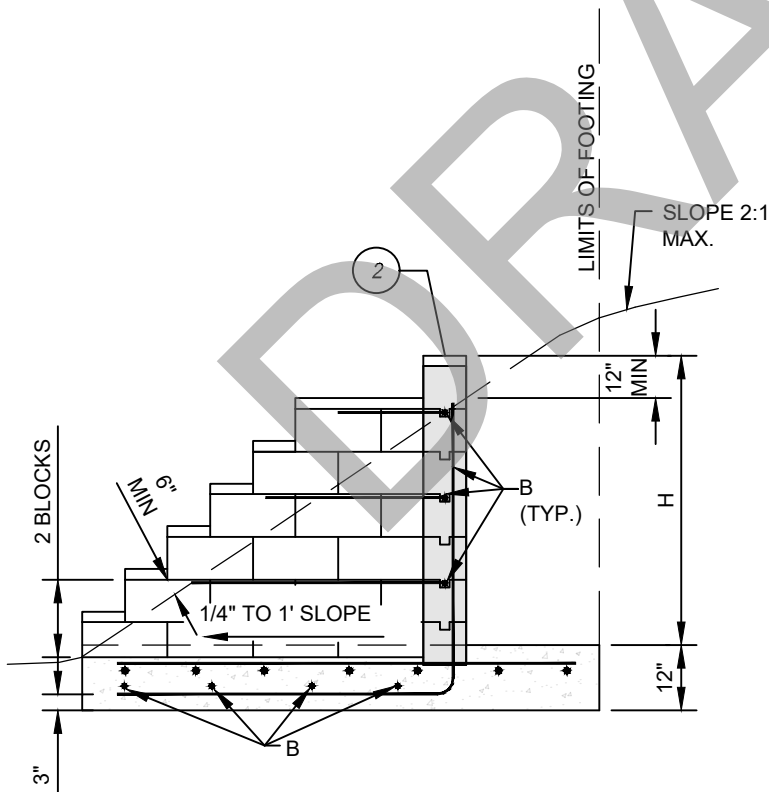

SECTION B-B

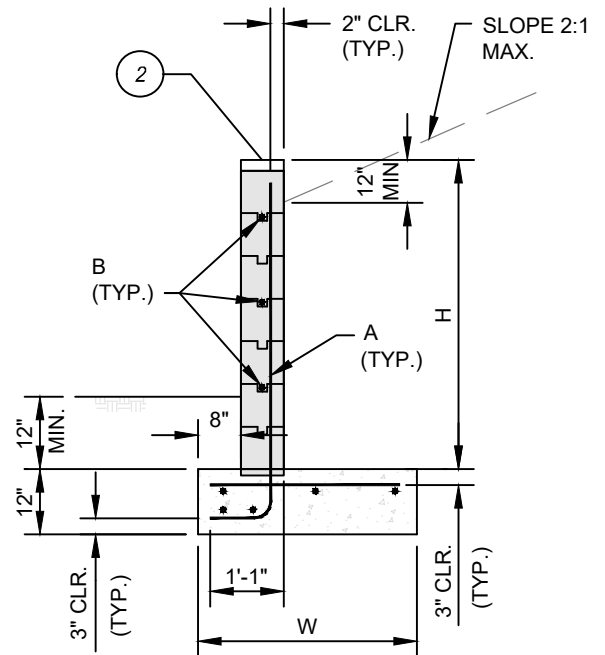

SECTION A-A

NO.	APPROVED	DATE

EAST ORANGE COUNTY WATER DISTRICT
ORANGE, CALIFORNIA

APPROVED BY _____

GENERAL MANAGER _____ DATE _____

DISTRICT ENGINEER _____ DATE _____

RETAINING WALL
1 OF 2

NO SCALE
STANDARD DWG.
W-23

LEGEND LIST OF MATERIALS

<u>ITEM</u>	<u>MATERIALS</u>
①	MASONRY BLOCK WALL, SEE NOTE 2.
②	BLOCK CAP, MATCH MASONRY BLOCK WALL STYLE AND COLOR.

NOTES:

1. RETAINING WALL TO BE CONSTRUCTED WITH ALL EOCWD APPURTENANCES WHEN A SLOPE EXISTS AT THE LOCATION OF THE APPURTENANCES. EXAMPLES INCLUDE CLEAN-OUTS, BACKFLOW DEVICES, FIRE HYDRANTS, AIR/VACS, FLUSH-OUTS, METERS, PRV STATIONS, TEST STATIONS, MANHOLES, VAULTS, VALVES AND WHEREVER REQUIRED BY THE DISTRICT REPRESENTATIVE.
 - A. CLEARANCE BETWEEN INSIDE WALL FACE AND THE OUTERMOST EDGE OF ANY EOCWD APPURTENANCE SHALL BE 36" MIN.
 - B. FOR POWERED APPURTENANCES, SUCH AS TRANSFORMERS, REFER TO THE ELECTRICAL PANELS MIN. CLEARANCE REQUIREMENTS.
2. MASONRY BLOCK SHALL BE 8" X 8" X 16" UNITS CONFORMING TO ASTM C-90 CLASS "S" AND CONCRETE MASONRY ASSOCIATION STANDARDS. BLOCK SHALL BE "SPLIT FACE" BEIGE COLOR FINISH ON ALL EXPOSED FACES. FILL ALL CELLS WITH GROUT.
3. MORTAR AND GROUT SHALL MATCH BLOCKWORK AND BE IN CONFORMANCE WITH SECTION 202-2 OF THE STANDARD SPECIFICATIONS FOR PUBLIC WORKS CONSTRUCTION.
4. OMIT MORTAR FROM THE FIRST VERTICAL JOINT OF THE BLOCK COURSE ABOVE FINISH GRADE TO PROVIDE WEEP HOLES FOR SUB-DRAINAGE PURPOSES.
5. CONCRETE SHALL BE CLASS 560-C-3250.
6. PROVIDE RAILING ON TOP OF WALL WHEN REQUIRED BY CODE.

REINFORCEMENT TABLE					
DESIGN H	3'-4"	4'-0"	4'-8"	5'-4"	6'-0"
DESIGN W	2'-8"	3'-0"	3'-4"	3'-8"	4'-0"
A VERT. REINF.	#4@16"	#4@16"	#5@16"	#6@16"	#6@16"
B VERT. REINF.	#4@16"	#4@16"	#5@16"	#6@16"	#6@16"
<p>DESIGN CRITERIA:</p> <p>1. EQUIVALENT FLUID PRESSURE = 35 PCF (TOE AND HEEL)</p> <p>2. ALLOWABLE BEARING CAPACITY = 1500 PSF</p>					

3/6/2023

\\192.168.1.50\Projects\EOCWD\EOCWD-2022-001 Water Standards Update\900 Engineering\301 CAD\Plansets\W-23-2.dwg

			EAST ORANGE COUNTY WATER DISTRICT ORANGE, CALIFORNIA APPROVED BY _____ GENERAL MANAGER _____ DATE _____ DISTRICT ENGINEER _____ DATE _____	RETAINING WALL 2 OF 2	NO SCALE STANDARD DWG. W-23
NO.	APPROVED	DATE			