

STANDARD SPECIFICATIONS AND  
DRAWINGS  
for  
SANITARY SEWERS



SEPTEMBER 2022

# 1. STANDARD SPECIFICATIONS FOR SANITARY SEWERS

## Table of Contents

..... 1-i

**1. Standard Specifications for Sanitary Sewers ..... 1-i**

**1.1 DEFINITIONS ..... 1-1**

**1.2 INSTRUCTIONS TO DEVELOPERS, ENGINEERS, AND HOMEOWNERS ..... 1-2**

    1.2.1 AUTHORITY ..... 1-2

    1.2.2 ANNEXATIONS ..... 1-2

    1.2.3 PERMITS ..... 1-2

    1.2.4 PLAN CHECKING, APPROVALS, AND FEES ..... 1-3

    1.2.5 INDEMNITY BOND ..... 1-3

    1.2.6 EASEMENTS AND RIGHT-OF-WAY ..... 1-3

**1.3 INSTRUCTION TO DESIGNERS ..... 1-4**

    1.3.1 GENERAL ..... 1-4

    1.3.2 PLANS ..... 1-4

    1.3.3 DESIGN ..... 1-5

**1.4 CONSTRUCTION ..... 1-10**

    1.4.1 SURVEYS ..... 1-10

    1.4.2 WORK INCLUDED ..... 1-10

    1.4.3 SCHEDULE ..... 1-11

    1.4.4 NOTICE ..... 1-11

    1.4.5 GENERAL WORK HOURS ..... 1-11

    1.4.6 PERMITS ..... 1-11

    1.4.7 EQUIPMENT AND LABOR ..... 1-12

    1.4.8 NOISE CONTROL ..... 1-12

    1.4.9 STOP ORDERS ..... 1-12

    1.4.10 CHANNEL OF COMMUNICATION ..... 1-13

    1.4.11 CONTRACTORS LICENSE ..... 1-13

    1.4.12 INSURANCE ..... 1-13

    1.4.13 LEGAL RELATIONS AND RESPONSIBILITY ..... 1-13

    1.4.14 HOUSE KEEPING AND RUBBISH CONTROL ..... 1-14

    1.4.15 CLEAN UP ..... 1-14

    1.4.16 FOUNDATIONS OR UNSUITABLE MATERIAL ..... 1-14

    1.4.17 OVEREXCAVATION ..... 1-14

    1.4.18 ODOR CONTROL ..... 1-15

    1.4.19 TEMPORARY HANDLING OF SEWAGE FLOW ..... 1-16

    1.4.20 DEWATERING ..... 1-20

    1.4.21 TRENCH WIDTH ..... 1-20

    1.4.22 TRENCH BACKFILL ..... 1-21

    1.4.23 JACKED CASING OR OPEN TRENCH CASING ..... 1-22

    1.4.24 HOUSE LATERALS ..... 1-24

    1.4.25 MANHOLES ..... 1-25

    1.4.26 CURED-IN-PLACE PIPE ..... 1-28

1.4.27	CURED-IN-PLACE MANHOLES .....	1-41
<b>1.5</b>	<b><u>MATERIALS</u></b> .....	<b>1-42</b>
1.5.1	GENERAL.....	1-42
1.5.2	VITRIFIED CLAY PIPE .....	1-43
1.5.3	DUCTILE IRON PIPE .....	1-49
1.5.4	PVC GRAVITY PIPE .....	1-50
1.5.5	PRECAST MANHOLES .....	1-50
1.5.6	POLYMER CONCRETE MANHOLES .....	1-51
1.5.7	GRADE RINGS .....	1-52
1.5.8	MANHOLE FRAME AND COVER .....	1-52
1.5.9	EPOXY RESIN .....	1-53
1.5.10	PORTLAND CEMENT CONCRETE .....	1-53
1.5.11	STEEL CASING OR OPEN TRENCH CASING.....	1-54
1.5.12	CIPP .....	1-54
<b>1.6</b>	<b><u>TESTING</u></b> .....	<b>1-58</b>
1.6.1	GRAVITY SEWERS .....	1-58
1.6.2	MANHOLES .....	1-61
<b>1.7</b>	<b><u>SAFETY</u></b> .....	<b>1-61</b>
1.7.1	EXCAVATIONS .....	1-61
1.7.2	CONFINED SPACE OPERATION .....	1-61
1.7.3	TRAFFIC CONTROL .....	1-62
<b>2.</b>	<b><i>Standard Drawings For Sanitary Sewers</i></b> .....	<b>2-0</b>

## **1.1 DEFINITIONS**

**Approved Equal** – A material or product that exceeds or is equivalent to, in the opinion of the Engineer, in all respects, that which is specified herein.

**Approved Plans** – Construction plans as specified herein approved by the East Orange County Water District attested to by the Engineer's signature.

**ASTM** - The American Society for Testing Materials. All references to the specifications of the ASTM are understood to refer to the current editions as revised and/or amended at the date of construction.

**Clean Sand** - Wherever the term "clean sand" is used in these requirements, it shall be defined as a soil having sand equivalent of 70 as determined in accordance with California Department of Transportation, Test No. "California 217".

**Contractor** – The persons, firm, or corporation entering into contract with the Owner or Developer for the performance of Work required under said contract, the District ordinances and these requirements.

**Commercial Development** - applies to any other construction or development that is neither Residential Development nor a Single Family Residence.

**Design Engineer** - A private Professional Engineer hired by the Owner or Developer for the design of the proposed Work.

**District** – East Orange County Water District (EOCWD).

**Engineer** – The District Engineer of the East Orange County Water District or duly authorized agent of the District Engineer.

**Final Acceptance** – The formal action by the District accepting the Work as fully completed, in accordance with these requirements.

**Inspector** – A duly authorized representative of the East Orange County Water District.

**Master Specifications** - The Master Specifications, East Orange County Water District, latest edition.

**OSHA** - Code of Federal Regulations, Title 29, Part 1910, U.S. OSHA, and State of California, Code of Regulations, Title 8, Construction Safety Orders.

**Owner or Developer** – The applicant requesting the installation or construction of sanitary sewers for integration with the sewer collection system of the District.

**Plans** – That part of the Approved Plans and specifications which consist of the plans, profiles, typical cross-sections and working drawings or exact reproductions thereof which show the location, character, dimensions and details of the Work to be done.

**Residential Development** - shall refer to any development consisting of multiple residences.

**Sewer System Management Plant (SSMP)** – The District’s plan to comply with State Water Resources Control Board Order No. 2006-0003-DWQ.

**Single-Family Residential** - shall refer to any residence involving only one dwelling unit per building site not withstanding an accessory dwelling unit.

**Standard Drawings** - That part of these requirements titled, “Standard Drawings”.

**Standard Specifications for Public Works Construction (SSPWC)** - The Standard Specifications for Public Works Construction, Green Book, latest edition.

**State Specification** - The Standard Specifications, State of California, Department of Transportation (Caltrans), latest edition.

**Work** – All the work specified in the standard requirements, plans, and standard drawings necessary to complete the construction of sanitary sewers.

## **1.2 INSTRUCTIONS TO DEVELOPERS, ENGINEERS, AND HOMEOWNERS**

### **1.2.1 AUTHORITY**

The Work shall be completed in accordance with the latest editions of the District’s standards, SSPWC, State Specifications, and all other applicable codes and standards.

Prior to the preparation of any plans, specifications or descriptions, the Developer (or the Developer’s engineer) shall meet with District staff to determine the extent of the District’s requirements for providing service to the development by the District.

### **1.2.2 ANNEXATIONS**

For properties outside the District’s boundary, annexation will be required. The Developer (or the Design Engineer) shall pick up instructions for Annexation to the Sanitation District. Contact the Engineering Department to verify if your property is in the District and for more information on the annexation process.

### **1.2.3 PERMITS**

No work shall be started until the Contractor has obtained all necessary permits. The Contractor shall obtain all permits and give all notices necessary and incidental to the due and lawful execution of the Work, and to the preservation of the public health and safety. The District will issue a permit for the Work to be done in addition to District facilities. The Contractor shall obtain and pay for all permits required by other agencies having jurisdiction over the Work.

#### **1.2.4 PLAN CHECKING, APPROVALS, AND FEES**

Prior to the construction of any facilities for the District (or facilities to become the property of the District), construction drawings for the subject Work shall require approval by the Engineer, and shall be stamped and signed by the Design Engineer preparing the Plans.

Approval by the Engineer on drawings for facilities to become the property of the District shall apply only to general design concepts with respect to the District's master planned capacity, maintenance procedures, and quality of materials. This will signify approval for a permit for construction, but will not guarantee the absence of errors and omissions.

When plan checking by the District is necessary, a plan check deposit fee per the District's current fee schedule shall be deposited. The first plan check fee may be waived at the District's discretion.

System capacity analyses are required for residential and commercial development projects to ensure adequate flow capacity for the new development. The cost of the analysis will be borne by the Developer.

New connections to the public sewer have an inspection fee per the District's fee schedule.

#### **1.2.5 INDEMNITY BOND**

If sewer facilities are to be constructed in a right-of-way under the jurisdiction of an agency requiring the District to sign the application for the encroachment permit, the applicant shall furnish the District with an indemnity bond satisfactory to the District prior to execution of the application.

#### **1.2.6 EASEMENTS AND RIGHT-OF-WAY**

Permanent easements, where absolutely necessary, shall be a minimum of 20 feet in width and shall be shown on the plans. Temporary easements for construction only shall be shown on the plans including date of termination.

Where applicable, permanent easements shall be recorded on the tract map, and granted to the East Orange County Water District. When applicable, separate easement documents for both permanent and temporary easements shall be prepared (on standard EOCWD title sheets and Standard Plan and Profile sheets) and presented to the District for acceptance and recording.

If District cleaning equipment cannot drive the entire length of a sewer and is unable to turn around or exit, the District will not accept the sewer easement.

### **1.3 INSTRUCTION TO DESIGNERS**

#### **1.3.1 GENERAL**

All Work shall be delineated in accordance with industry standards and requirements.

#### **1.3.2 PLANS**

##### **1 COVER SHEET**

The cover sheet shall be the East Orange County Water District standard sheet. A standard blank cover sheet template will be provided upon request by the District, and include at a minimum the following:

- As a minimum, the cover sheet will delineate:
  - Vicinity Map (General Orange County)
  - Location Map and Sheet Index Map (Specific location)
  - Name of project including contract number, title, and District number
  - Approval blocks for signature of all agencies required, in addition to the signature block of the Design Engineer preparing the plans and the General Manager and District Engineer's approval block.
  - General notes which describe Work to be done in summary terms.
  - In lieu of that shown (and when applicable), a separate survey control sheet shall be prepared delineating horizontal and vertical survey control, bench marks, abbreviations, legend delineations and other applicable data which may be included thereon.

##### **2 PLAN AND PROFILE**

- All Work shall be shown and delineated in accordance with the applicable industry standards.
  - Scale shall be 1" = 40' (horizontal), and 1" = 4' (vertical). Any other scale shall receive pre-approval from the Engineer.
  - Construction notes, numbers, and quantities shall be used and all applicable notes of construction shall be called out.
  - Typical section, hydraulic data, and benchmark data shall be shown.
- Soil boring information shall be shown and shall reference the boring report, including the date the boring was performed and the name of the geotechnical firm.

- Utility locations shall be shown as accurately as possible in both plan and profile in accordance with standard practice for underground utility plans delineations per ASCE 38-02.

### 3 DETAILS

Applicable detail sheets shall be prepared and shall show all necessary details for construction survey controls.

### 4 SIZE OF PLANS

All plans shall be 24 x 36 inches in size.

### 5 FINAL APPROVAL

The plans shall be signed by a Civil Engineer Registered in the State of California, under whose jurisdiction the plans were prepared. When final approval for a permit is issued by the District, the Design Engineer and internal District Engineer's signature will be shown. Infrastructure that will be transferred to the District requires the District Engineer's approval.

## 1.3.3 DESIGN

### 1 CRITERIA FOR AVERAGE DAILY FLOW CALCULATIONS

<u>Land Use</u>	<u>Coefficient GPD Per DU</u>
Low Density Residential <i>West of Newport Blvd and North of Foothill Blvd</i>	200
<i>East of Newport Blvd</i>	220
<i>Lemon Heights &amp; Crown Heights</i>	250
Medium Density Residential	150
High Density Residential	100
Mobile Home Park	150
<u>Land Use</u>	<u>Coefficient GPD Per AC</u>

Community Commercial	2,500
Old Town Commercial	2,000
Professional Office	3,000
Industrial Area	3,000
Open Space	129
Church	300
Public	300
Special Care	600

	Coefficient
<u>Land Use</u>	<u>GPD Per Student</u>
School	600

## 2 PEAK FLOW

Average daily flow times two (2) equals peak flow in all pipe sizes larger than 8 inches. For 8-inch pipe use multiplication factor of 2.5. No pipe smaller than 8 inches is allowed for constructing sewer mains. No pipe smaller than 8 inches is allowed for constructing sewer mains.

## 3 VELOCITY

Velocity shall not be less than 2 ft /sec. unless otherwise approved by the Engineer. Maximum slope shall not exceed 10 percent unless approved by the Engineer. There will be additional requirements including siphons.

## 4 REQUIREMENTS FOR DEPTH OF FLOW VERSUS DIAMETER OF PIPE

The following summarizes requirements for depth of flow (d) versus diameter of pipe (D) in sewer pipe.

<u>Diameter of Pipe (d)</u>	<u>Max d/D</u>
8 inches – 18 inches	0.50
21 inches – 24 inches	0.75

## 5 DEPTH OF COVER

Unless otherwise approved by the Engineer, depth of laterals at property line shall be a minimum of 5 feet. Minimum depth of cover over mainline sewers shall be 7 feet.

## 6 MANHOLE CRITERIA

Manhole locations:

- At changes of slope
- At changes of direction

- At junction of laterals
- At changes of pipe size
- At termination of sewers
- At special locations as designated by the Engineer
- At changes in type of pipe material, i.e., V.C.P. to D.I., unless at water crossings and approved by the Engineer.

Commercial laterals are required to be a minimum of 8" in size and may require a manhole at both ends.

Maximum distance between manholes:

Pipe Size

8 inches – 12 inches	400 feet
15 inches – 18 inches	500 feet
18 inches and over	600 feet unless otherwise approved by the Engineer

**7 SIPHON CRITERIA**

Siphons shall be avoided where possible. If a siphon is necessary, note that:

- Dual siphons are preferred to allow isolation of one for maintenance and inspection.
- Siphons shall be designed for a minimum velocity of 3 feet per second at design average flows. Siphons shall have a minimum internal diameter of 8-inches.
- Siphons shall be designed so that the daily dry weather peak flow shall provide a minimum velocity of 4 feet per second. That is, under average conditions at least once per day the flow shall be at or above 4 feet per second for at least 30 minutes.
- Siphons shall be designed so that peak wet weather flow produces no more than 2-feet of surcharge (above the soffit of the pipe) in the upstream siphon structure (or any other manhole).
- For corrosion reasons, plastic pipe (pressure rated HDPE or PVC) is preferred for siphons and air lines. The use of VCP must be approved by the District Engineer. If VCP is used, it shall be concrete encased.
- Siphons shall not have sharp horizontal angles or changes of grade.
- The invert of the downstream manhole shall be at least 0.1-feet lower than the invert of the upstream manhole.
- The maximum angle of the downstream (rising) leg approaching the outlet junction structure shall be no more than 15 degrees from horizontal. The maximum angle of the upstream leg shall be no more than 30 degrees from horizontal.
- Siphons shall have a junction structure at each end. Rectangular junction structures are preferred over circular structures where more than one siphon pipe is connected to the structure.

- Where used, multiple, reduced sized siphons shall be based upon a detailed engineering flow analysis. Flow analysis shall consider present and future low, average, and high flows. Particular attention shall be paid to average diurnal flow conditions.
- Dual (or multiple) siphons shall be designed so that normal flow can be diverted to either barrel so that the other barrel can be cleaned. To reduce maintenance requirements, isolation of siphon pipes shall be possible using stop plates (or logs), not gates. Junction structures and stop plates shall be designed so that plates can be moved to isolate or open siphons without a confined space entry.
- Where multiple siphons are used the inverts shall be at the same elevation, and isolation stop plates shall be provided that can be used as overflow weirs between the siphon pipes
- Siphons shall have an adequately sized air jumper line between junction structures, (minimum of 6-inch diameter) for cleaning and maintenance. Dual air lines are not required. Provide the design basis including calculations in the design report.
- Air jumper systems shall have a mechanism for removing condensate. Condensate removal shall be sized based on an engineered calculation of condensate production, and District experience, and shall be designed to provide long service in corrosive conditions. Design shall specify minimum slope for drainage. Where practical, overhead air jumpers that are self draining to the manholes are preferred.
- Siphons and air balance lines shall be designed to accommodate the District's cleaning methods, including rodding, jetting, and tire cleaning. Locate manholes so that they are accessible, and to minimize traffic control setup. Adequate space shall be provided for equipment setup and vehicle parking, including a buffer for safety. Provide utility truck parking area on the downstream side of the upstream manhole.
- Air jumpers shall have a headloss of less than 0.10-inches of water column (0.0036 psi) across the system at maximum airflow. The following method for estimating the maximum airflow ( $Q_{air}$ ) is suggested (from Project 2-68 PDR TM-1, Dudek & Associates, 2006):
  - Assume  $d/D = 0.3$  (because maximum airflow occurs at  $d/D = 0.3$ ).
  - Assume a Reduction Factor (RF) = 0.5 to relate air velocity ( $V_{air}$ ) to sewage velocity ( $V_{ww}$ ).
  - If replacing an existing air jumper, RF may be modified based on field measurements of  $Q_{air}$ ,  $d/D$  and  $Q_{ww}$ , but never to be below 0.25 or above 0.8 (except where mechanical ventilation affects airflow).
  - $Q_{air} = (RF)(\text{HeadspaceArea})(V_{ww})$ .
- Identify all siphon pipe inverts on the plans. Accurately specify actual internal diameters (ID) for all designed pipelines in the plans. If more than one pipe material is allowed in the design, show both actual IDs. The nominal size of the pipe is not sufficient.
- Specify procedures for pressure testing of siphons and air jumpers.

- Specify Closed Circuit Television Video (CCTV) of siphons and jumpers for acceptance.

Note: The District typically cleans jumpers and siphons with a jetter. Cleaning lengths are limited to about 600 feet for jet cleaning. Cleaning lengths include upstream manhole depth as well as sewer length.

## 8 RADIUS OF CURVATURE

Normally, the District insists upon straight sections between manholes; however, when specifically approved by the Engineer, minimum radius of curvature for V.C.P. sewers shall be:

<u>Pipe Size</u>	
8 – 12 inch	250 feet
15 – 18 inch	350 feet
21 – 24 inch	400 feet

Lesser radius of curvature may be permitted by the Engineer in special cases. Vertical curves shall not be allowed.

## 9 SHOP DRAWINGS

Shop drawings for all fabricated materials or equipment incorporated in the Work shall be submitted for the approval of the Engineer. The Contractor shall obtain and check the shop drawings and other pertinent data for conformance with all requirements of the drawings and specifications. After completion of such checking and verification, the Contractor shall submit four copies of the shop drawings and pertinent data to the District for review and approval. Hard copies or digital copies of shop drawings and pertinent data are allowed. The District Engineer may require information in regards to design, installation, operation, and compliance of specified items and their compliance with the Plans and Specifications.

## 10 CRITERIA FOR THE SEPARATION OF WATER MAINS AND SANITARY SEWERS

### ***Water Main Separation Requirements***

Separation requirements must abide by the California Waterworks Standards (California Code of Regulations (CCR), Title 22, Division 4, Chapter 16, Section 64572) which establish criteria for the separation of new water mains from non-potable pipelines.

### ***Sewer Main Installation***

New sewer mains shall be installed in accordance with the separation criteria and vertical order (sewer mains are to be installed below water mains) as presented above.

### ***Special Construction Requirements***

Certain conditions may call for the installation of pipelines with less horizontal or vertical separation distance, a different vertical orientation, a different crossing angle, or other aspect than what is required by the regulations. In these situations, an alternative may be proposed for approval by the local water agency and the State Division of Drinking Water.

## **1.4 CONSTRUCTION**

### **1.4.1 SURVEYS**

All surveys shall be performed by a licensed land surveyor or civil engineer as required by the State of California and shall be completed and shown on the plans in accordance with the OC Survey Standards Manual.

Surveyors Cut Sheets: All developer fees must be paid per the District's current fee schedule prior to work commencing. Additionally, no work shall commence prior to the preparation of the sewer cut sheets and duplicate copies shall be supplied to the Inspector. The cut sheets shall be prepared only by a Land Surveyor Licensed or Civil Engineer Registered in the State of California. The cut sheets shall include the location of wyes, house laterals at the property line and manhole rim elevations by sewer stationing. House lateral stakes shall be marked to indicate cut, sewer stationing and lot number.

### **1.4.2 WORK INCLUDED**

Principal items of Work for the construction of sewer mains and laterals shall include, but is not limited to the following:

- Traffic control
- Clearing and grubbing or pavement removal
- Odor control and temporary handling of sewage
- Trenching and shoring
- Pipe bedding
- Pipe laying
- Construction of structures
- Placing and compacting of backfill
- Balling and cleaning of sewer
- Air testing of sewer

- Paving or grading over trench
- Raising manhole covers to grade
- Obtaining required permits
- Obtaining easements
- Obtaining approval for a variant from the State mandated construction standards for separation of water and sewer, when necessary
- Final inspection

### **1.4.3 SCHEDULE**

No work shall commence without a preconstruction meeting. The Contractor shall submit a schedule to the Engineer outlining his proposed construction sequencing. Whenever the Contractor varies the period during which work is carried out each day, the Contractor shall give due notice to the Engineer so that proper inspection may be provided. At such time as the Contractor's work on the sewer becomes less than a full day's activity, it shall be the Contractor's responsibility to notify the Inspector, on a daily basis, of the Work requiring inspection. Any Work done in the absence of the Inspector shall be subject to rejection. Inspections shall not be scheduled on Fridays without prior permission by the District.

### **1.4.4 NOTICE**

Notice shall be given to the Engineer at least two working days in advance of commencement of work.

### **1.4.5 GENERAL WORK HOURS**

Normal working hours are Monday through Thursday between 7:00 a.m. and 5:00 p.m. Exceptions will only be allowed when the sewage flow or diversion cannot be accommodated during those hours, the authority(s) having jurisdiction or the encroachment permit prohibits work during those hours, or if liner installation and preliminary lateral cuts cannot be completed in the normal working hours.

For exceptions, the following shall apply:

All live laterals must be opened with a preliminary cut to relieve the flow the same day as the installation. The preliminary cuts shall be a smooth round cut with a minimum diameter of 3-inches. Final lateral cuts using a wire brush may be completed during normal working hours on a later day.

### **1.4.6 PERMITS**

The Owner(s), Developer, or their Contractor shall secure all excavation permits, authority(s) having jurisdiction permits, and all licenses required for the Work. Special attention is called to the District's connection charges and it shall be the Owner's responsibility to ascertain these charges and pay for such prior to any connections to the District sewage facilities, including lateral connections at property lines. Copies shall be

recorded with the District prior to commencement of work. Permits will not be issued without payment of fees.

#### **1.4.7 EQUIPMENT AND LABOR**

The District's equipment and labor, including the District's representative(s) assigned to monitor the work, shall not be utilized by the Contractor at any time in the performance of the work. The District's representatives' presence shall be accommodated by the Contractor and safe access shall be provided to all areas of the work for which observation or inspection may be required.

#### **1.4.8 NOISE CONTROL**

All equipment used during service shall be muffled and maintained in good operating condition. All internal combustion engine driven equipment shall be fitted with intake and exhaust mufflers that are in good condition. No air compressors or diesel engines will be permitted to operate between the hours of 5:00 PM and 7:00 AM, unless prior approval from the District and any authority(s) having jurisdiction has been obtained.

#### **1.4.9 STOP ORDERS**

If the Contractor (for the Owners or Developer) fails to perform the work, or any separate part thereof in accordance with the notes, details, plans, or the applicable portions of these specifications, or the permit requirements therefore, the District may, without prejudice to any other right or remedy, serve written notice upon the Contractor and the sureties of the intention to terminate all work by the Contractor. The District reserves the right to stop work if working conditions are deemed unsafe. The said notice will contain the reasons for such intention to terminate all work by the Contractor and, unless, within 10 days after the service of such notice, such violations cease, and satisfactory arrangements for the corrections thereof are complete, the final termination notice shall be issued.

In the event of any such termination, the District shall immediately serve written notice thereof upon the surety and Contractor. The surety shall then have the right to take over and perform the Contract provided, however, that, if the surety within 15 days after the serving of a notice of termination does not give the District written notice of its intention to take over and perform the work, or does not commence performance thereof within 30 days from the date of serving said notice, the District may take over the work and prosecute the same to completion by Contract or by any other method it may deem advisable for the account and at the expense of the Contractor and the sureties, who shall then be liable to the District for any excess cost or other damage occasioned the District thereby. In such event, the District may, without liability for so doing, take possession of and utilize in completing the work such materials, appliances, plants, and other property belonging to the Contractor that may be on the work site and be necessary therefore. For any portion of such work that the District elects to complete by furnishing its own employees, materials, tools, and equipment, the District shall be

compensated for such in accordance with the schedule of compensation for force account work.

#### **1.4.10 CHANNEL OF COMMUNICATION**

Any notice required or given under the contract shall be in writing, be dated, and signed by the party giving such notice or his duly authorized representative, and be served as follows:

- If to the District: by personal delivery or by deposit in the United States mail.
- If to the Contractor: by personal delivery to the Contractor or to his authorized representative at the site of the project or by deposit in the United States Mail.
- If to the Surety or any other person: by personal delivery to said Surety or other person or by deposit in the United States mail.

All mailed notices shall be in sealed envelopes, shall be sent by certified mail with postage prepaid, and shall be addressed to the addresses indicated in the Contract Documents, or such substitute addresses which a party designates in writing and serves as set forth herein.

#### **1.4.11 CONTRACTORS LICENSE**

All work shall be performed by a contractor licensed in the State of California with the designation of Class A. Work may be performed by a contractor with a C-42 License with prior approval.

#### **1.4.12 INSURANCE**

Prior to commencement of subject Work, the Contractor, in addition to other requirements with respect to insurance, shall meet the District's insurance requirements or contract insurance requirements and shall provide the District with a Certificate of Insurance. A Certificate of Insurance shall be presented to the District before inspection is scheduled and performed. If the permit connection is for another public agency or a city, such agency or city shall, along with the District be added to the Contractor's policy as an additional insured by way of an endorsement per the District's current requirements. Higher insurance requirements may be required depending on the scope of work and will be determined by the District when the permit is issued.

#### **1.4.13 LEGAL RELATIONS AND RESPONSIBILITY**

The Contractor shall keep itself fully informed of all laws, ordinances and regulations which in any manner affect those engaged or employed in the Work, or the materials used in the Work, or which in any way effect the conduct of the Work and of all such orders and decrees of bodies or tribunals having any jurisdiction or authority over the same. If any discrepancy or inconsistency is discovered in the plans, drawings, specifications or other documents in relation to any such law, ordinance, regulation,

order of decree, the Contractor shall forthwith report the same to the District in writing. The Contractor shall at the time observe and comply with and shall cause all of its agents and employees to observe and comply with all such existing and future laws, ordinances, resolutions, regulations, orders and decrees and shall, to the maximum extent permitted by law, protect and indemnify the District and its Board of Directors, officers, employees, and agents against any and all claims, liabilities, damages, losses, or costs (including attorney fees and costs) arising from or based on the violation of any such law, ordinance, regulation, order or decree, whether by the Contractor or its employees.

#### **1.4.14 HOUSE KEEPING AND RUBBISH CONTROL**

Contractor shall keep the project site in a neat and clean condition, free from any accumulation of rubbish and debris. The Contractor shall dispose of all rubbish and waste materials of any nature occurring at the work site and shall establish regular intervals of collection and disposal of such materials and waste. Disposal of all rubbish and surplus materials shall be off the site of construction, at the Contractor's expense, in accordance with Federal, State and local codes and ordinances governing locations and methods of disposal, and in conformance with all applicable safety laws and the requirements of the OSHA Safety and Health Standards for Construction

The Contractor shall cleanup and restore surface conditions and structures to their original condition, or better, upon completion of the work, at no additional cost to the District.

#### **1.4.15 CLEAN UP**

Prior to Final Completion of the Work, the Contractor shall restore the Project site affected by the operations to a condition at least equal to that existing prior to the Work at no additional expense to the District.

#### **1.4.16 FOUNDATIONS OR UNSUITABLE MATERIAL**

If excessively wet, soft, spongy, unstable or similarly unsuitable material is encountered at the surface upon which the bedding material is to be placed, the unsuitable material shall be removed to a depth as determined in the field by the Engineer and replaced with 3/4-inch maximum crushed base rock and geotextile (filter fabric) or other requirements as determined by the Engineer.

#### **1.4.17 OVEREXCAVATION**

All overexcavation as determined by the Engineer shall be rectified by the placement of 3/4-inch maximum crushed rock base to design grade of the pipe and geotextile (filter fabric).

## **1.4.18 ODOR CONTROL**

### **1 GENERAL**

#### ***Work Description***

When the Work of the project includes opening live sewer lines, the Contractor shall adhere to the following odor control requirements.

The Contractor shall furnish all labor, materials, and equipment required, and shall carry out effective measures wherever and as often as necessary to prevent the discharge of a nuisance odor in keeping with the District's goal of no odor complaints. During construction, the Contractor shall notify the Engineer and the Inspector at least forty-eight (48) hours in advance when potential odor-causing activities are scheduled for construction.

#### ***Contractor Submittals***

The Contractor shall develop and submit to the Engineer, for review, an Odor Control / Monitoring Plan (OCMP). The OCMP shall be developed and submitted to the Engineer a minimum of twenty-one (21) days prior to any construction activity that may potentially release nuisance odors. The OCMP shall contain the following:

- Site locations of all potential odor-causing activities within the Work area
- Scheduled construction date(s)
- Expected construction duration(s)
- List of potential receptors and distances to those receptors
- Proposed locations of odor monitors
- Plan for odor monitoring using the gas monitors
- Catalog cuts for gas monitors
- Operation and maintenance procedures to prevent odors
- Mitigation measures
- Emergency contact numbers
- Emergency equipment.

### **2 PRODUCTS**

The Contractor shall obtain fully functioning and calibrated hydrogen sulfide gas analyzers to measure hydrogen sulfide emission concentrations from potential odor areas during construction.

### **3 EXECUTION**

Odor control measures shall be implemented during all activities that include, but are not limited to: opening of the collection system facilities (i.e., pipes, structures), demolition, tie-ins, sewage bypassing, and dewatering.

The Contractor shall seal all structures properly to eliminate the potential for release of nuisance odors.

The Contractor shall stop all work that creates a complaint, and mitigate the cause to the satisfaction of the District prior to resuming work.

Contractor shall furnish all labor, materials, and equipment required and shall carry out effective measures wherever and as often as necessary to prevent the discharge of a nuisance odor from its operation into the atmosphere in such quantity as will violate the regulations of any legally constituted authority such as but not limited to those of the South Coast Air Quality Management District.

#### **1.4.19 TEMPORARY HANDLING OF SEWAGE FLOW**

##### **1 GENERAL**

###### ***Work Description***

The Contractor shall be responsible for the temporary handling of sewage throughout the construction of the project. This includes field verification of flows; design, installation and operation of a temporary pumped bypass system; and a Spill Prevention, Control and Countermeasure Plan (SPCCP), including a Contingency Plan detailing actions to be taken in the event of a sewage spill. All spills shall be contained and returned to the sewer system.

The Contractor may use flow through piping (in-line bypass) installed in the manhole as a bypass solution. In-line bypasses shall be as large as possible and verified continuously to be free flowing.

Aboveground by-pass sewage pumping is permitted upon approval by the Engineer and in accordance with the requirements of this specification section. If aboveground bypass is required, a single aboveground bypass pipeline and system shall be provided with primary and backup pumps, piping and vehicle crossing ramps as specified herein. Bypass pipeline material shall be adequate for pressure and flow and be approved by the District. All aboveground sewage bypassing systems shall be sealed to eliminate the potential for release of nuisance odors.

The Contractor shall be responsible for all aspects of the mobilization, set-up, operation, testing, management, 24-hour trained personnel for monitoring and operation, pressure testing, spill containment at all points of suction, discharge, and ramp crossing connections, spill management including clean up, replacement of damaged property and fines.

### ***Contractor Liability***

The Contractor shall be responsible for the continuity of sanitary sewer service to each facility connected to the sewers during the execution of the Work to be performed. In the event that sewage backup occurs and enters dwellings or other structures due in any part to a failure of the bypass piping system, the Contractor shall be responsible for cleanup, repair, property damage costs, fines imposed by jurisdictional authorities, and all claims arising therefrom. All spills shall be contained and returned to the sewer system.

In the event the Regional Water Quality Control Board levies a fine on the District because of a sewage spill caused by the Contractor (directly or indirectly) due to lack of attention to procedures or other negligence, the Contractor shall be held responsible and liable for reimbursing the District for the entire amount of each fine imposed.

### ***Contractor Submittals***

Unless otherwise indicated, the following shall be submitted to the Engineer, for each in-line bypass or aboveground bypass installation, fifteen (15) days after receiving the Notice to Proceed, as specified herein:

- Plans showing proposed temporary handling of sewage flow procedures, routing and protection of bypass lines, containment areas, equipment location, schematic of pump set-up and discharge, and proposed sequencing.
- Shop drawings for the sewage bypass pipe material and fittings pipe repair kits and procedures, spill recovery mats, and video camera.
- Complete bypass pump system details, field verified and certified characteristic curves, documentation on electrical systems, controls, and instrumentation.
- Flow calculations for sizing pumps and piping, signed and stamped by an engineer Registered in the State of California.
- Spill Prevention, Control, and Countermeasure Plan as described herein, including a Contingency Plan containing actions to be taken in the event of a sewage spill.
- For all aboveground bypasses, the Contractor shall provide a map of the construction site indicating locations of the following:
  - 1) All storm drains in the area
  - 2) Sewer manholes in the area

- 3) Bypass equipment
- 4) Staging area / construction area.

### ***Bypass Pumping Equipment***

Pumps shall be engine-driven, variable-speed, self-priming non-clog sewage pumps. The Contractor shall use pumps of sufficient capacity to meet maximum flow within the pipe to prevent spills. All pumps shall be capable of cycling from 0 gpm to the required pump capacity.

The Contractor shall perform flow monitoring to verify sewage flows for pump sizing. All pumps considered for the bypass Work shall be capable of passing 3-inch sized solids.

Standby pumping equipment shall be at the site and connected to the system continuously during pumping to provide 100 percent standby pumping capacity. The Contractor shall provide sufficient manpower to continuously monitor and service the pumping equipment on a 24-hour basis while in operation, to activate standby equipment, and clean pumps due to ragging, if necessary. The Contractor-provided bypass system manpower shall be trained in pump operation and maintenance and be fully capable of operating all aspects of the bypass system.

Pumps shall be capable of running twenty-four (24) hours per day as required to complete the Work.

All pumps and standby pumps shall be engine-driven and shall be critically-silenced for sound control in accordance with the applicable city's noise provisions.

The Contractor shall be responsible for traffic barricades and temporary chain-link fencing around bypass pumps. Sound attenuating acoustic blankets shall be installed on temporary chain-link fencing to provide an additional level of sound dampening over the critically-silenced pump enclosures.

### ***Bypass Piping***

Aboveground bypass piping shall consist of one temporary aboveground pipeline. Pipe material shall be adequate for pressure and flow. Pipe material shall be submitted and approved by the District. Pipe shall be sized to handle maximum flow within the pipe.

The bypass pipe shall be laid above ground and shall be provided with manufactured road crossings at each road or driveway. A ramp bypass shall be prefabricated for each size of ramp provided to allow removal and cleaning of the bypass ramp in the event of blockage. One spare road crossing of each size

shall be stored on the project site for quick replacement of duty crossing if needed.

#### ***Manhole Level Sensors with Alarm***

Each bypass suction wetwell or manhole shall be fitted with a liquid level sensor connected to an audible alarm and light. Level shall be set to indicate a pumping failure as early as possible.

#### ***Rubber Matting for Blocking of Storm Drain Inlets***

Rubber matting shall be premium grade neoprene sheet, 1/8-inch thick minimum, 48 inches wide; 60 to 70 durometer.

#### ***Spill Prevention, Control and Countermeasure Plan (SPCCP)***

The Contractor shall prepare a Spill Prevention, Control, and Countermeasure Plan (SPCCP). The Plan shall include preventative measures to be taken to prevent a wastewater spill, and also actions to be taken in the event of an accidental wastewater spill. Maximum importance shall be placed on protecting spilled wastewater from reaching storm drains. The SPCCP shall contain any calculations required for sizing equipment. The Contractor shall submit for the Engineer's acceptance all duty and emergency equipment for containment, cleanup, and repair of any spill. Specifics for each bypass installation shall include, but not be limited to, the following, as applicable:

- Pipe repair kits
- Spare inflatable pipe plugs
- Spare pipe sections, and other relevant equipment
- Spare valves
- Spare vehicle ramps
- Standby pumping truck(s)
- Secondary containment around duty and standby pump installations.

The SPCCP shall also contain the names and telephone numbers of at least three (3) Contractor's staff members on who can be contacted 24 hours per day by phone and brought on-site at any time to address on-site emergencies.

#### ***Vacuum Tanker Trucks***

The Contractor shall provide reservation of two vacuum-capable tanker trucks and personnel. Such equipment shall be available to the project for on-site response within 30 minutes upon receiving a notice over 24 hours per day for the duration of the field work.

### ***Protection of Storm Drains***

The Contractor shall protect storm drains during construction. In the event of a spill, no sewage shall be allowed to flow into any storm drain. The storm drain inlets shall be blocked with rubber matting and sand bags. Rubber matting shall overlap storm drain inlets by a minimum of 24 inches on all sides. For inlets located in traffic areas, the grating may be removed, wrapped with rubber sheeting, and reinstalled to provide a barrier to the inlet.

### ***Gravel Bags***

The Contractor shall provide gravel bags to hold the rubber sheeting in place.

### ***Spill Report***

In the event of a sewage spill(s), the Contractor shall obtain from the Engineer the up-to-date EOCWD Collection System Problem Report form, fill it out and submit it with the associated photos to the Engineer for each spill.

### ***Contact***

In the event of a sewage spill(s), the Contractor shall immediately notify District's Operations Manager or Collections Supervisor and provide the following preliminary information:

- Date and time of the spill
- Location of the spill
- Volume of the spill
- Did the spill enter the storm drain.

## ***1.4.20 DEWATERING***

The Contractor shall provide and maintain at all times during construction ample means and devices with which to promptly remove and properly dispose of all water from any source entering excavations or others parts of the Work.

No concrete footings or floors shall be laid in water nor shall water be allowed to rise over them until the concrete or mortar has set at least 8 hours. Water shall not be allowed to rise against unshored walls. There shall be dewatering operations continuously to protect the jobsite.

## ***1.4.21 TRENCH WIDTH***

Sewer trenches shall be excavated in such a manner as to produce a trench no less than 12 inches and not more than 16 inches in width over the largest outside diameter of pipe. Trench width shall be measured at a point 6 inches above top of pipe.

Where trench width exceeds the maximum specified above, overwidth bedding details shall be required.

All trenches shall be in compliance with the minimum requirements of OSHA at all times.

**1.4.22 TRENCH BACKFILL**

**1 GENERAL**

All trenches shall be backfilled after pipes, fittings, and appurtenances have been installed. Requirements of the local agency having jurisdiction in public rights-of-way shall take precedence in all cases.

**2 PUBLIC STREETS**

Backfill and compaction in public streets, above the pipe zone, and the street section (including asphalt, slurry seal, and base, if required) shall be in accordance with the requirements of the local agency having jurisdiction.

**3 NON-PAVED AREAS**

Material shall be in accordance with the requirements of the local agency having jurisdiction or the property owner. Native backfill material, if allowed, shall be free from all rocks larger than 3 inches in any dimension and other deleterious material. Backfill from the pipe zone to the natural ground surface shall be compacted in lifts not to exceed 18 inches and to a minimum relative density of 90 percent. The Contractor shall dispose of excess material, off-site, in a legal manner.

**4 PIPE ZONE**

Crushed rock shall be crushed aggregate base material and shall conform to the California Standard Specifications for Public Works Construction, Section 200-1.2 and shall meet the following gradation:

Sieve Sizes	1-1/2-inch	1-inch	3/4-inch	3/8-inch
2-inches	100	---	---	---
1-1/2-inches	90 - 100	100	---	---
1-inch	20 - 55	90 - 100	100	---
3/4-inch	0 - 15	30 - 60	90 - 100	---
1/2-inch	---	0 - 20	30 - 60	100
3/8-inch	0 - 5	---	0 - 20	90 - 100
No. 4	---	0 - 5	0 - 5	30 - 60

Sieve Sizes	1-1/2-inch	1-inch	3/4-inch	3/8-inch
No. 8	---	---	---	0 - 10

Crushed aggregate base materials used for pipe bedding shall be 3/4 - inch unless otherwise called for by the project plans and specifications or as directed by the District. Crushed miscellaneous base materials may be substituted for crushed aggregate base materials by special permission from the District. In such cases, materials shall conform to the requirements of the California Standard Specifications for Public Works Construction, Section 200-2.4, except that gradation of the materials shall still comply with the percentages by weight on the table above.

In areas of high groundwater or unsuitable soils geotextile (filter fabric) may also be required.

### **1.4.23 JACKED CASING OR OPEN TRENCH CASING**

#### **1 JACKING PIT**

**Excavation Protection:** The approach trench for jacking or boring operations shall be adequately shored to safeguard existing substructures and surface improvements and to ensure against ground movement in the vicinity of the casing portal.

**Structural Support for Jacking Equipment:** Heavy guide timbers, structural steel, or concrete cradle of sufficient length shall be placed in the approach trench of the jacking pit and firmly bedded on the required line and grade to provide accurate control of jacking alignment. Adequate space shall be provided to permit the insertion of the lengths of casing to be jacked. The structure of timbers and structural steel sections shall be anchored to ensure action of the jacks in line with the axis of the casing. A bearing block consisting of a timber or structural steel framework shall be inserted between the jacks and the end of the casing to provide uniform end bearing over the perimeter of the casing and distribute the jacking pressure evenly.

#### **2 SECTIONAL SHIELD OR JACKING HEAD**

**Equipment:** A sectional shield or steel jacking head shall be attached to the leading section of the casing to extend around the outer surface of the upper two-thirds of the casing and to project at least 18 inches beyond the driving end of the casing. The sectional shield or jacking head shall not protrude more than 1/2-inch outside of the outer casing surface. The head shall be anchored to prevent any wobble or alignment variation during the jacking operation.

**Removal of Excavated Material:** To avoid loss of ground outside the casing, excavation shall be restricted to the least clearance necessary to prevent binding and shall be carried out entirely within the jacking head and not in advance of the head. Excavated material shall be removed from the casing as jacking progresses and no accumulation of excavated material within the casing will be permitted.

### **3 CONTROL OF ALIGNMENT AND GRADE**

Application of jacking pressure and excavation of material ahead of the casing as it advances shall be controlled to prevent the casing from becoming earthbound or deviating from the required line and grade shown on the Plans. Allowable grade deviations in horizontal and vertical alignments shall be no greater than 0.2 feet per 100 feet in any direction over the length of the jacking and boring operation. A maximum cumulative deviation shall not exceed 0.5 feet overall. Do not encroach upon the minimum annular space detailed. The District will check line and grade at intervals not exceeding 40-feet to ensure compliance with plans.

### **4 GROUTING**

Exterior of Casing: Immediately after completion of the jacking operation, grout shall be injected through the grout connections of casings 30-inches in diameter and larger in such a manner as to completely fill all voids outside the casing pipe resulting from the jacking operation. Where loss of ground outside the casing is suspected, additional grout connections shall be welded to the casing. Grout pressure shall be controlled to avoid deformation of the casing and/or avoid movement of the surrounding ground. After completion of grouting, the grout connections shall be closed with extra heavy black steel threaded plugs.

Interior of Casing (between carrier pipe and casing): After grouting the exterior of the casing and installing the carrier pipe, the interior of the casing shall be completely filled with grout if the casing depth is greater than 10-feet below the finished ground surface

### **5 INSTALLATION OF CARRIER PIPE**

Insertion of Carrier Pipe: After grouting the exterior of the casing pipe, the interior shall be cleaned and the carrier pipe installed. The carrier pipe shall be installed per the manufacturer's recommended spacing. Spacers shall be installed at mid-sections if the carrier pipe segment is over ten (10) feet long.

Securement: The top of the carrier pipe shall be blocked to prevent flotation. The carrier pipe shall be secured in a manner satisfactory to the District Representative to prevent floating and subsequent change of grade.

Grade Adjustment: The carrier pipe grade shall be adjusted as required by changing the height of the casing spacer riser and / or the thickness of the runner pad skids to compensate for any grade variations of the casing pipe. Care should be taken to ensure that the carrier pipe does not come in contact with and is insulated from the casing pipe.

Failure to Achieve Required Grade: If the alignment of the casing pipe is such that the carrier pipe grade cannot be met, the grade of the casing pipe shall, if required by the District, be adjusted. If realignment is not deemed feasible by the District, another casing pipe meeting the required grade shall be installed. The abandoned casing pipe shall be filled with sand and the ends plugged with twelve (12) inch thick masonry plugs. Realignment or replacement work shall in no way result in additional costs to the District.

Testing: Before backfilling the jacking and receiving pits, the carrier pipe shall have passed an initial pressure or leakage test.

Closing the Jacking Pit and Receiving Pit: After jacking equipment and muck from the tunnel have been removed from the approach trench of jacking pit, the bottom of the jacking pit shall be prepared for pipe foundation and bedding. Remove all loose and disturbed material below pipe grade to undisturbed earth.

Backfill: The jacking pit and receiving pit represent overwidth trench conditions.

## **1.4.24 HOUSE LATERALS**

### **1 GENERAL**

House laterals are owned and maintained by the property owner.

The Contractor shall install house laterals and wye or tee branch fittings of the size and location as indicated on the Plans. The Contractor shall not proceed with placement of the house laterals until such time as the surveyor has staked the laterals at sewer center and property lines.

No bends greater than one-eighth shall be used in the construction of house laterals within public right-of-way. Laterals shall be joined to wye branch fittings or a saddle, if applicable, at the sewer main by the use of eighth bends positioned to obtain the desired lateral slope. All fittings or laterals that are to be left unconnected shall be plugged with a vitrified clay or neoprene stopper as specified herein.

### **2 DEPTH AND SLOPE OF LATERALS**

Minimum cover over house laterals at the property line shall be 5 feet. Slope of house laterals shall be 1/4 inch per foot (0.02 ft/ft) minimum. In cases where property grades relative to the sewer are critical, the Engineer may approve a lesser slope.

### **3 LOCATION MARKING**

The ends of all house laterals shall be marked as follows:

- In cases where laterals are to be connected to the dwelling unit during the same phase of construction, and where curb improvements are included, the Contractor shall mark each house lateral by chiseling the letter "S" 1-1/2 inches high on the top of the curb.
- In cases where laterals are not to be connected to the dwelling unit, the Contractor shall place a 2 x 4 treated redwood stake extending vertically from the end of the lateral to within 3 feet of finish grade. In

addition, where curbs are to be constructed, the Contractor shall chisel the letter "S" on the top of the curb.

## **1.4.25 MANHOLES**

### **1 GENERAL**

Sewer manholes shall be constructed in accordance with the Standard Drawings and at the locations shown on the Plans. The manholes shall be constructed of precast concrete manhole units in accordance with the section entitled "Precast Manholes" herein and the related Standard Drawings. Manholes shall be built without steps. Manholes on piping over 21-inch nominal size shall be lined with polyurethane. Other conditions will also require lining including:

- Slopes greater than 10%
- Significant changes in slope
- Pressurized lateral entering the manhole

### **2 ON NEW SEWERS**

The manhole base shall be poured in place against wood or sandbag forms with Class "A" 650-WC-4000 Portland cement concrete. All wood forms shall be removed prior to slurry placement. The manhole stubs and sewer main shall be set before the concrete is placed and shall be rechecked for alignment and grade before the concrete has set. The various inlets and outlets to the manhole shall be located as indicated on the plans and as detailed in the Standard Drawings. All transitions shall be smooth and of the proper radius to give an uninterrupted transition of flow. The radius shall be not less than the inlet pipe radius. The concrete shall have a slump not greater than 3 inches. The concrete base may be shaped with a wood float and shall receive a hard steel trowel finish prior to the concrete setting. In the event additional mortar is required after initial set has taken place, the surface to receive the mortar shall be primed, and the mortar mixed with an approved adhesive in the amounts and proportions as recommended by the manufacturer and as directed by the Inspector in order to secure as chip-proof a result as possible. The rebar bases shall be set a minimum of 24 hours before the manhole construction is continued. If less than 24 hours, add accelerator to concrete mix. In certain critical situations, the time of setting may be reduced upon approval of the Engineer.

Concrete manhole shafts shall be joined with a 1-1/4-inch square bead of plastic sealing compound in the joint groove toward the outside of the manhole and on the shoulder immediately above the first bead. Refer to Standard Drawing S-13 and S-14 for further detail. The joint to the base shall have a third bead placed at the inward corner of the groove. Grade rings shall be joined with a minimum thickness of 1/2 inch of cement mortar to form a watertight and smooth joint. Any infiltration of ground water shall be stopped by a repair approved by the Engineer.

Whenever new manholes are constructed in unpaved areas, in specific circumstances and as approved by the District, the manhole cover shall be set 18 inches above finish grade.

In all cases during construction, the Contractor shall place 1/2-inch plywood inserts on the manhole shelf to prevent debris from entering the sewer in the event the manhole protection cover is disturbed.

### **3 ON EXISTING SEWERS**

While excavating in the vicinity of the existing sewer, Contractor shall use extreme care to prevent damage to the sewer pipe. No mechanical equipment shall be used in the vicinity of the existing sewer. Hand digging and/or the use of a vacuum excavator is required to ensure no damage to the existing sewer pipe. The base shall be poured in place against wood or sandbag forms with Class "A" 650-WC-4000 Portland cement concrete. On existing sewers, bypass and cutting in the manhole is required. Building over the top of existing pipe requires District approval. Manhole stubs shall be provided on both sides of the main and shall be rechecked for alignment and grade before concrete has set. All wood shall be removed prior to placement of slurry. Manhole stubs shall be plugged with factory plugs, or brick and mortar for pipe over 21 inches, prior to connecting the incoming sewer. This plug shall not be removed until the offsite Work has been completed and the sewer cleaned, and with the approval of the Inspector.

Pipe saw cutting shall take place only under inspection by the District and only after the manhole and onsite sewer have been completed and cleaned. Sewer main sizes 12 inches and larger shall be sawcut to remove the top portion of the pipe. Care shall be taken to prevent cuttings from entering the existing sewer. The Contractor shall be required to have the sewer trunk balled and cleaned by an experienced sewer maintenance contractor if, in the opinion of the Inspector, excessive amount of cutting or debris has entered the sewer. Upon refusal of the Contractor to clean the District line immediately, the District staff will clean the line and the Contractor shall pay all expenses incurred by the District. All equipment and materials shall be securely fastened by a rope at all times while in a manhole.

After cut out, all rough edges shall be worked to produce a true and neat opening. The edges of the pipe shall then be filled and smoothed with mortar. The surface to receive mortar shall be primed and the mortar mixed with an approved adhesive in the amounts as recommended by the manufacturer and as directed by the Inspector. For PVC-lined manholes, weld the manhole liner to the PVC pipe liner.

The bases shall be set a minimum of 24 hours before the manhole shafting is set. In certain critical situations where traffic is a problem in the opinion of the Inspector, the time of setting may be reduced provided a 2-percent mix of calcium chloride is added to the concrete.

Manhole shafting shall be as specified under the section entitled "On New Sewers" herein.

Whenever new manholes are constructed in unpaved areas, in specific circumstances and as approved by the District, the manhole cover shall be set 18 inches above finish grade.

Whenever grading or paving operations follow pipe removal, the Contractor shall place 1/2-inch plywood inserts on the manhole shelf to prevent debris from entering the sewer in the event the manhole protective cover is disturbed.

#### **4 POLYMER CONCRETE MANHOLES**

Contractor shall adhere to the latest editions of the reference documents.

Concrete Manhole risers, cones, flat lids, grade rings and manhole base Sections shall be designed by manufacturer to exceed the design criteria of ASTM C478.

Polymer Concrete Manhole risers, cones, flat lids, grade rings and manhole base sections shall be designed by manufacturer to meet loading requirements of ASTM C478, ASTM C857 and ACI 350-06 as modified for polymer concrete manhole design as follows:

Polymer Concrete Mix Design shall consist of thermosetting resin, sand, and aggregate. No Portland cement shall be allowed as part of the mix design matrix. All sand and aggregate shall be inert in an acidic environment.

Reinforcement – Use acid resistant reinforcement (FRP Bar) in accordance with ACI 440.1R-06 for polymer concrete design.

The wall thickness of polymer concrete structures shall be at least 95% of the manufacturer's stated design thickness.

Thermosetting Resin - The resin shall have a minimum deflection temperature of 158° F when tested at 264 psi (1.820 mPa) following Test Method D 648. The resin content shall not be less than 7% of the weight of the sample as determined by test method D 2584. Resin selection shall be suitable for applications in municipal sewer system corrosive conditions.

Each polymer concrete manhole component shall be free of all defects, including indentations, cracks, foreign inclusions and resin starved areas that, due to their nature and degree or extent, detrimentally affect the strength and serviceability of the component part. The nominal internal diameter of manhole components shall not vary more than 2%. Variations in height of two opposite sides of risers and cones shall not be more than 1/8 inch. The under run-in height of a riser or cone shall not be more than 1/4 in/ft of height with a maximum of 1/2 inch in any one section.

Marking and Identification - Each manhole shall be marked with the following information - Manufacturer's name or trademark, Manufacturer's location and Production Date.

Manhole joints shall be assembled with a bell/spigot or shiplap butyl mastic or gasketed joint so that on assembly, manhole base, riser and top section make a continuous and uniformly watertight manhole. Joint sealing surfaces shall be free of dents, gouges and other surface irregularities that would affect joint integrity.

Minimum clearance between wall penetrations and joints shall be per manufacturer's design.

#### **1.4.26 CURED-IN-PLACE PIPE**

##### **1 GENERAL**

The work involves the repair or rehabilitation of existing sanitary sewers using steam-cured or hot-water cured CIPP per Greenbook 500-1.4. UV curing can be used as approved by the District. The Contractor shall furnish all labor, materials, equipment, traffic control, infiltration control, flow bypassing, and appurtenant incidentals for the lining of various lengths of pipelines.

Information relative to structures numbers, pipe sizes, pipe materials, and pipe lengths shall be provided using: record drawing, map book page, CCTV inspection report and CCTV inspection video.

If applicable, removal and replacement of fences, repair to yards, lawns, sidewalks, driveways, and other public or private property, due to actions or processes related to the work being performed shall be included in the cost of the Work.

The CIPP shall consist of a resin-impregnated flexible tube that is inverted into the existing force main pipeline and expanded to fit tightly against the host pipe via steam or water cure (project to specify whether both curing methods are acceptable or just one). The resin system shall be cured by elevating the temperature of the steam or water used for the inflation to a sufficient enough level for the initiators in the resin to effect a full polymerization (hardening). In UV curing method, UV lights are used to run through the pipe which prompts resin to cure. The finished new pipe shall, after curing, be a monolithic fiber and resin composite matrix that will be chemically resistant to withstand exposure to domestic sewage.

Vent and/or exhaust noxious fumes or odors generated during and remaining after the curing process is completed. This process shall remain in place at all manholes, laterals, etc. until noxious odors have dissipated to an acceptable level in accordance with CAL/OSHA requirements for the materials used and there is no more air pollution or potential health hazard left to the general public or the construction workers.

The District reserves the right to negotiate with the Contractor in situations where a pipe repair or pipe rehabilitation need may be better served at less cost by the use of a technology other than hot-water-cured CIPP, and the District may use this Contract for said repair so long as the District and the Contractor reach an agreement on the scope of work and price. This work shall be in accordance with the requirements of the Greenbook where applicable.

CIPP installation work includes:

- a. Notification of affected addresses 72 hours in advance of work
- b. Temporary "No Parking" signs 72 hours in advance of work
- c. Traffic Control
- d. Plugging and/or By-Passing Existing Sewage Flows in accordance to the District's Sewer System Management Plan (SSMP).
- e. Cleaning the pipe.
- f. Pre-inspection via CCTV to confirm and document the cleanliness of the pipe and to identify existing defects, roots, and infiltration.
- g. When necessary, re-cleaning to: cut and remove all roots, cut or grind all protruding laterals, and/or remove all tuberculation, grease, debris, and other deposits.
- h. When necessary, performance of infiltration repairs via chemical grouting or other method approved by the District.
- i. Performance of a final, pre-installation CCTV inspection that documents that the pipe is ready for CIPP installation.
- j. Installing CIPP.
- k. Curing the liner by steam, hot water, or UV.
- l. When present, reestablishing existing sewer service lateral connections using a remote-controlled unit and sealing the lateral connection using a PVC "top hat" acceptable to the District.
- m. Inspecting the final CIPP installation via CCTV (post-inspection) in the presence of a District inspector.
- n. Repairing any defects in the installed CIPP at no additional cost to the District. This work, if required, shall be followed by a second post-inspection by CCTV at no additional cost to the District, confirming the acceptability of the repair.

The rehabilitation of sewers shall be accomplished by the installation of a resin-impregnated flexible tube which, when cured-in-place, shall be continuous and tight-fitting over the entire length of an insertion run between two or more manholes or access points and shall be free from visual defects such as foreign inclusion, dry spots, pinholes, and delamination. Overlapping or other means of jointing the CIPP between existing manholes

is unacceptable and shall result in the section of sewer and CIPP between existing manholes to be removed and repaired by the Contractor at the Contractor's expense.

The CIPP shall extend the full length of the sewer and provide a structurally sound, jointless and water tight new pipe within the existing sewer to withstand all imposed hydrostatic loads. The Contractor shall be responsible for proper, accurate and complete installation of the CIPP using the system selected by the Contractor .

The CIPP shall fit sufficiently tight within the existing sewer so as to not leak at the manholes, at service connections, or through the wall of the installed CIPP liner. If leakage occurs the Contractor shall seal these areas to stop all leakage using a material compatible with the CIPP as directed by the Engineer at no additional cost to the District. If leakage occurs, the liner shall be repaired or removed as recommended by the CIPP manufacturer.

The CIPP shall be designed for fully deteriorated pipe conditions as defined in ASTM F1216. The installed CIPP shall meet or exceed all Contract specified physical properties listed in Subsection 4.3, Table 1.

The installed CIPP system shall have previously passed the Green Book Chemical Resistance Test Section 211-2 and ASTM D5813 and accepted for inclusion in the Green Book as an acceptable rehabilitation material per Green Book Part 5 System Rehabilitation Section 500 – Pipeline.

The Contractor shall be responsible for confirming locations of all lateral service connections prior to installing the CIPP. All existing and active lateral service connections shall be reinstated per Green Book Section 500-1.1.7 Miscellaneous Service Connections. Service connection sealing shall be performed in accordance with Green Book Section 500-4 Service Lateral Sealing Connection. The lateral sealing connection shall be compatible with the CIPP material and ensure a positive connection to the lateral section. It shall be the responsibility of the Contractor to clear the sewer of obstructions, including protruding laterals, that will interfere with the installation and long-term performance of the liner.

The Contractor shall furnish all samples for product testing at the request of the District.

Neither the CIPP system, nor its installation, shall cause adverse effects to any of the District's processes or facilities. The use of the product shall not result in the formation or production of any detrimental compounds or by-products at any District facility. The Contractor shall notify the ENGINEER and identify any by-products produced as a result of the installation operations, test and monitor the levels, and comply with any and all local waste discharge requirements. The Contractor shall cleanup, restore existing surface conditions and structures, and repair any CIPP segments determined to be defective. The Contractor shall conduct installation operations and schedule cleanup in a manner to cause the least possible obstruction and

inconvenience to traffic, pedestrians, businesses, and property owners or tenants.

The Bid prices submitted by the Contractor, shall include labor, equipment and materials for the various Bid items necessary for furnishing and installing, complete in place, CIPP in accordance with this Specification section. All items of the Work not specifically mentioned herein which are required to make the product perform as intended and deliver the final product as specified herein shall be included in the respective lump sum and unit prices Bid.

The Contractor shall perform all Work in a safe manner as specified elsewhere in the Contract Documents.

The Contractor shall be responsible to measure the inside diameter of the pipeline (or pipelines) which are to receive CIPP.

## **2 QUALIFICATIONS**

Contractor shall meet all of the following qualifications:

- a. Contractor must have a minimum of 5 years of experience installing CIPP in the method used.
- b. All staff on a project site shall be trained in confined space rescue and have all necessary rescue equipment on site during the duration of the project.
- c. Technicians performing the pre-installation CCTV inspection and post-installation CCTV inspection shall be Pipeline Assessment Certification Program (PACP) certified by the National Association of Sewer Service Companies (NASSCO).
- d. Contractor's project site foreman or project manager shall be certified as a CIPP inspector by the NASSCO Inspector Training and Certification Program (ITCP).

All required certificates shall be provided to the District as part of the Contractor's bid, for review by the District.

### 3 REFERENCE DOCUMENTS

Contractor shall adhere to the latest editions of the reference documents listed below.

<u>Reference</u>	<u>Title</u>
ASTM C581	Standard Practice for Determining Chemical Resistance of Thermosetting Resins Used in Glass Fiber Reinforced Structures Intended for Liquid Service
ASTM D578	Standard Specification for Glass Fiber Strands
ASTM D638	Standard Test Method for Tensile Properties of Plastics
ASTM D790	Standard Test Methods for Flexural Properties of Unreinforced and Reinforced Plastics and Electrical Insulating Materials
ASTM D2990	Standard Test Methods for Tensile, Compressive, and Flexural Creep and Creep-Rupture of Plastics.
ASTM D3567	Standard Practice for Determining Dimensions of "Fiberglass" (GlassFiber-Reinforced Thermosetting Resin) Pipe and Fittings.
ASTM D5813	Standard Specification for Cured-in-place Thermosetting Resin Sewer Piping Systems
ASTM F1216	Standard Practice for Rehabilitation of Existing Pipelines and Conduits by the Inversion and Curing of a Resin-impregnated Tube
ASTM F1743	Standard Practice for Rehabilitation of Existing Pipelines and Conduits by Pulled-in-Place Installation of Cured-in-Place Thermosetting Resin Pipe (CIPP)
ASTM F 2019	Standard Practice for Rehabilitation of Existing Pipelines and Conduits by the Pulled in Place Installation of Glass Reinforced Plastic (GRP) Cured-in-Place Thermosetting Resin Pipe (CIPP).
ASTM F2304	Standard Practice for Sealing of Sewers Using Chemical Grouting

ASTM F2454 Standard Practice for Sealing Lateral Connections and Lines from the Mainline Sewer Systems by the Lateral Packer Method, Using Chemical Grouting

Standard Specifications for Public Works Construction (Greenbook)

Greenbook Section 500-1 - Pipeline Rehabilitation

Greenbook Section 500-1.1 - Requirements

Greenbook Section 500-1.4 - Cured-in-Place Pipe Liner

Contractor shall immediately notify the District if conflicts arise between this SOW and a manufacturer's requirements prior to proceeding with the work.

#### **4 REQUIRED SUBMITTALS**

The following submittals shall be provided to the District for each repair:

- A. Contractor's detailed work plan covering mobilizing, cleaning operations, pre-CCTV inspection, bypass pumping, traffic control, debris removal procedure, mineral deposit grinding procedure, chemical grout sealing procedure, installation procedure, method of curing, service reconnection, quality control, testing to be performed, final CCTV inspection, and all else necessary and appropriate for a CIPP liner installation.

Submit a general work plan for all work anticipated, followed by specific work plans for each installation. Specific plans shall contain additional site-specific general plan modifications or additions and any exceptions. Specific plans shall include a detailed installation schedule conforming to the requirements of this Contract. Plans shall include complete manufacturer's information on the specific CIPP product to be used. No work shall be performed by the Contractor until the District has approved the submittal in writing.

- B. Certification demonstrating:
  - Contractor is currently licensed by the State of California to perform CIPP installation.
  - NASSCO PACP certifications for personnel performing CCTV work.
  - NASSCO ITCP CIPP Inspection certification for foremen or project manager.
- C. The lead personnel including the superintendent, the foreman and the lead crew personnel for the CCTV inspection, resin wet-out, the CIPP installation, CIPP curing and the robotic service reconnections must have a minimum of three (3)

years of total experience with the CIPP technology proposed for this Contract and must have demonstrated competency and experience to perform the Work contained in this Contract. The name and experience of each lead individual performing Work on this Contract shall be submitted.

- D. All CIPP installation leads shall be NASSCO ITCP certified for CIPP. The Contractor shall provide a copy of the lead's certificate. The lead shall be present on site at all times during the installation of the CIPP.
- E. All CCTV inspection shall be performed by a CCTV inspection operator who is NASSCO PACP certified. The Contractor shall submit a copy of the operator's certificate.
- F. Confined Space Entry and Rescue Plan as specified elsewhere in this Scope of Work to demonstrate proper training and certification of all individuals entering the manhole and all individuals providing support during manned entry.
- G. Engineering design calculations, in accordance with ASTM F1216, for each length of CIPP to be installed including the thickness of the CIPP. It shall be acceptable for the Contractor to submit a design for the most severe sewer condition and apply that design to all of the sewer sections. These calculations shall be performed and certified by a qualified Professional Engineer registered in the State of California. All calculations shall include data that conforms to the requirements of this Specification section.
- H. Short and long term physical properties of component materials and construction, showing conformance with Greenbook and pertinent ASTM material requirements.
- I. Manufacturer requirements and recommendations for material storage and temperature control; CIPP handling; installation; resin heating and curing; trimming and finishing; and QA/QC procedures.
- J. CIPP end and connection sealing materials and methods to be used to seal ends of sectional repairs and connect to manholes. Include method, procedure, and information to provide either an adhesive, water-tight seal to the sewer; or a water-tight mechanical seal between the cured liner and sewer pipe wall which will not prohibit the installation of future structural liners, or interfere with sewer cleaning equipment or CCTV inspection equipment.
- K. For service lateral connections, PVC "top hats" shall be installed to provide a water-tight seal between the cured liner and sewer pipe wall; or between the service line adapter and the sewer and the service lateral wall.

- L. Third party 10,000-hour, 50-year Flexural Creep Modulus test data demonstrating compliance with ASTM D2990.
- M. Safety Data Sheets (SDS) for all hazardous chemicals used or expected to be on-site including resin, catalyst, cleaners, and repair agents.
- N. Repair and replacement procedures recommended by the CIPP manufacturer.
- O. Traffic control plans approved by the authority(s) having jurisdiction over a particular project site(s).
- P. Pre-installation CCTV inspection report and video showing the pipe has been properly cleaned and all debris, roots, calcium deposits, and other foreign objects have been removed.
- Q. Post-installation CCTV inspection report and video showing the CIPP has been installed properly and without defects.
- R. CIPP installation quality control reports including:
  - A complete description of the proposed wet-out procedure for the proposed technology
  - The Manufacturer's recommended cure schedule - for each diameter and thickness of CIPP to be installed.
  - Outline of testing procedures for resin and products according to ASTM standards prior to beginning the Work, and certified test results after completion of the testing
  - Wet-out logs that indicate calculated volume of resin required, volume of resin used, wet out date, and other pertinent information
  - Curing logs that indicate installation times, pressures, and temperatures during warm up, exothermic, and cool down.
- S. A field-cured liner sample from each CIPP installation, if requested by the District. Restrained samples should be provided where feasible.
- T. Two-year warranty provided by the Contractor. The Contractor shall warrant the installation of the liner/repair system for a period of two (2) years after final acceptance of the work.
- U. Procedures, methods, and reporting of sewage monitoring, spills, and handling. Notifications to the public regarding the Work, construction schedule, impacts to public right of way access, and parking, and contact information

shall be provided to the District first for review and approval prior to notifying the impacted homeowners and businesses.

## **5 SEWAGE MONITORING**

Contractor shall be responsible for monitoring upstream sewage flow at all times during the work and immediately notify the District's representative(s) of any manhole surcharging or overflow. Contractor shall contain and control all sewage flows in the pipe. Contractor shall provide means to contain and control any potential overflows to protect property and storm drainage from contamination or physical damage where any potential spills may end up. The Contractor shall be responsible for paying the full amount of any fines levied by others toward the District as a result of the Contractor's work where negligence, poor work, improper preparation or procedures result in sewage spills.

Contractor shall be responsible for any fines levied by others; reimbursement to the District or others of any incurred costs, damage, cleanup, restoration of flow, and any disruption of service costs to customers as of a result of Contractor's work. This is in addition to any and all costs incurred by the customer.

Contractor shall also notify the District's Operations Manager and/or Collections Supervisor immediately of any apparent non- Contractor related spills and/or any abnormal conditions.

## **6 SEWER CLEANING**

Contractor shall clean the interior of the existing sewer prior to installation of the CIPP. All debris and obstructions that will affect the installation and the final CIPP installation shall be removed and disposed of.

Contractor shall conduct heavy cleaning in the project sewer prior to operation of the bypass. The Contractor shall be responsible for disposal of any debris removed from the sewer during the cleaning operation in accordance with applicable laws and ordinances. Contractor shall catch and remove cleaning operation debris in a basket at the downstream manhole of each reach.

Precaution shall be taken by the Contractor in the use of cleaning equipment to avoid damage to the existing pipe. The repair of any damage, caused by the cleaning equipment, shall be the responsibility of the Contractor.

Any remaining standing water in existing sewer sags, manhole inverts, or other locations in the sewer shall be removed by pulling a foam pig through the sewer, or by other means acceptable to the Engineer or Inspector, immediately prior to inversion of the CIPP.

Line Obstructions - It shall be the responsibility of the Contractor to clear the sewer of obstructions, including protruding laterals, that will interfere with the installation and long-term performance of the liner.

## 7 INSTALLATION

Contractor shall perform post-cleaning video inspections of the sewers and CIPP. Only NASSCO Pipeline Assessment Certification Program (PACP) certified personnel trained in locating breaks, obstacles and service connections by CCTV shall perform the inspection. The Contractor shall perform the video inspection with no water in the bottom of the pipe so the pipe invert can be seen to ensure that all debris has been removed. The Contractor shall provide the Engineer with a copy of the post-cleaning, pre-installation videos and suitable logs, in digital format for review of the CIPP and for later reference by the District.

### A. Preparation

Prior to installation, the Contractor shall prepare and submit a Confined Space Entry and Rescue Plan to the Engineer as specified elsewhere in the Contract Documents. In addition, all personnel performing Confined Space Entry shall attend a Job Hazard Analysis (JHA) conducted by the District.

### B. Installation of the CIPP

**Resin Impregnation:** The quantity of resin used for tube impregnation shall be sufficient to fill the volume of air voids in the tube with additional allowances for polymerization shrinkage and the loss of resin during installation through irregularities in the original pipe wall. A vacuum impregnation process shall be used. The point of vacuum shall be no further than 25-feet from the point of initial resin introduction. After vacuum in the tube is established, a vacuum point shall be no further than 75-feet from the leading edge of the resin. The leading edge of the resin slug shall be as near to perpendicular to the longitudinal axis of the tube as possible. A roller system shall be used to uniformly distribute the resin throughout the tube.

CIPP fabricator shall deliver chilled wet specimens of the resin compound to the Engineer during wet outs.

The wet-out tube shall be positioned in the sewer using the method specified by the manufacturer. Care should be exercised not to damage the tube as a result of installation. The tube should be pulled in or inverted through an existing manhole or accepted access point and fully extend to the next designated manhole or termination point.

Prior to installation and as recommended by the manufacturer remote temperature gauges or sensors shall be placed inside the sewer at the invert to monitor the temperatures during the cure cycle. CIPP and/or sewer interface temperature shall be monitored and logged during curing of the CIPP.

Curing shall be accomplished by utilizing steam, hot water, or UV curing in accordance with the manufacturer's recommended cure schedule, ASTM F1216, ASTM F1743, and ASTM F2019. The boiler and hydraulic pumps used shall be enclosed to reduce noise. The boiler used shall be of a sufficient BTU capacity to ensure a faster cure time to meet the work hour restrictions in Section 1.4.5. The curing source, or in and output temperatures, shall be monitored by thermo couple gauges installed prior to CIPP installation and logged during the cure cycles. The manufacturer's recommended cure schedule shall be used for each

CIPP segment installed, and the CIPP wall thickness and the existing ground conditions with regard to temperature, moisture level, and thermal conductivity of soil, per ASTM as applicable, shall be taken into account by the Contractor.

Air inversion steam cure (AISC) shall have the curing process monitored with temperature sensor cable to continuously monitor the cure temperature of CIPP liner along the entire length of pipe. Temperature readings shall be taken in accordance to resin manufacturer recommendations and the Site-Specific Operations Protocol.

## **8 COOL DOWN**

The Contractor shall cool the CIPP in accordance with the approved CIPP manufacturer's recommendations.

Temperatures and curing data shall be monitored and recorded, by the Contractor, throughout the installation process to ensure that each phase of the process is achieved as accepted in accordance with the CIPP System manufacturer's recommendations.

## **9 FINISH**

The installed CIPP shall be continuous over the entire length of a sewer section and be free from visual defects such as foreign inclusions, dry spots, pinholes, major wrinkles and de-lamination. The CIPP shall be impervious and free of any leakage from the sewer to the surrounding ground or from the ground to inside the CIPP.

Any defect, which will or could affect the structural integrity or strength of the CIPP, shall be repaired at the Contractor's expense.

The beginning and end of the CIPP shall be sealed to the manhole at every termination. Hydrophilic sealing material for non-pressure locations shall be compatible with the sewer end and shall provide a watertight seal.

For lateral service connections, the connection sewer interface shall be sealed with a PVC "top hat" to provide a water tight connection.

If the wall of the CIPP leaks, it shall be repaired or removed and replaced with a watertight CIPP as recommended by the manufacturer of the CIPP system.

## **10 CIPP REPAIR/REPLACEMENT**

In the event that the installed CIPP needs repair or replacement of defective CIPP, the following requirements shall apply.

The Contractor shall outline specific repair or replacement procedures for potential defects that may occur in the installed CIPP.

Defects in the installed CIPP that will not affect the operation and long term life of the product shall be identified and defined.

Repairable defects that may occur in the installed CIPP shall be specifically defined by the Contractor based on manufacturer's recommendations, including

a detailed step-by-step repair procedure, resulting in a finished product meeting the requirements of these Contract Specifications.

Un-repairable defects that may occur to the CIPP shall be clearly defined by the Contractor based on the manufacturer's recommendations, including a recommended procedure for the removal and replacement of the CIPP at no additional cost to the District.

## **11 FINISH MANHOLE CONNECTION AND RECONNECTIONS OF EXISTING LATERAL SERVICES**

A seal, consisting of a resin mixture or hydrophilic seal compatible with the installed CIPP shall be applied at all non-pressure manhole connections and lateral reinstatements in accordance with the CIPP System manufacturer's recommendations.

Existing lateral services shall be internally reconnected as indicated in the Contract Documents.

Reconnections of existing lateral services shall be made after the CIPP is installed, fully cured, cooled down, and pressure tested. It is the Contractor's responsibility to make sure that all active lateral service connections are reconnected after pressure testing.

A CCTV camera and remote cutting tool shall be used for internal reconnections. The machined opening shall be at least 95 percent of the lateral service connection opening and the bottom of both openings shall match. The opening shall not be more than 100 percent of the lateral service connection opening. The edges of the opening shall not have sewer or CIPP fragments, which may obstruct flow or snag debris.

The Contractor is responsible for reinstating all lateral connections and ensure a positive connection to the laterals.

In the event that service reinstatements result in openings that are greater than 100 percent of the lateral service connection opening, the Contractor shall install a CIPP type repair, sufficient in size to completely cover the over-cut lateral service connection at no additional cost to the District.

Coupons of pipe material resulting from lateral service tap cutting shall be collected at the next manhole downstream of the sewer rehabilitation operation prior to leaving the site. Coupons may not be allowed to pass through the system.

## **12 TESTING OF INSTALLED CIPP**

- A. Testing and inspection shall include CCTV inspection in steam cured and water cured reaches, and other items as required. Low pressure air test shall also be used in steam cured reaches.
- B. Chemical resistance – Components of the CIPP system installed shall meet the chemical resistance requirements of Green Book and the ASTM standards. Evidence of passing these chemical resistance tests shall be provided together

with the shop drawings for review and acceptance prior to installation of these materials.

- C. The physical properties for each segment of the installed CIPP shall be verified through field sampling and laboratory testing. All labor, materials, and third party testing laboratory necessary for all testing shall be furnished by the Contractor, as part of the Work at no additional cost to the District. All materials testing shall be performed by an independent third party laboratory that: can demonstrate experience and is approved by the CIPP manufacturer; and that is submitted by the Contractor with shop drawings to the Engineer for review and acceptance.
- D. The installed CIPP thickness of minimum 4 millimeters shall be measured for each CIPP section installed. If the CIPP thickness does not meet the accepted design tolerance, the CIPP shall be repaired or removed. The CIPP thickness shall have tolerance of minus 5% and plus 10% of the accepted design thickness. The Contractor shall remove a minimum of one sample from every CIPP section of installed CIPP to be used to check the CIPP thickness. The samples shall be taken by core drilling 2-inch diameter test plugs at accessible locations near manholes. As an alternative, the Contractor may submit for the District's review and acceptance, industry proven non-destructive methods for confirming the thickness of the installed CIPP.
- E. All tests shall be in accordance with applicable ASTM test methods to confirm compliance with the requirements specified in these Contract Documents: flexural modulus of elasticity and flexural strength per ASTM D-790; and tensile strength and tensile modulus per ASTM D-638.
- F. The Contractor shall provide samples for testing under field inspection by the District from the actual installed CIPP. One restrained sample and one plate sample shall be provided for each inversion. Restrained samples shall be cut from a section of cured CIPP that has been inverted or pulled through a like diameter sewer which has been held in place to cure for the same time and under the same heat and pressure conditions as the CIPP. Plate samples shall be contained in a sample box and made from the same carrier tube material (same nominal thickness) and resin as used for the CIPP. Plate samples shall be cured in the same heat environment and for the same time as the CIPP.
  - 1. A 2-foot sample shall be large enough to provide a minimum of six specimens for flexural testing and six specimens for tensile testing. All curing, cutting and identification of all samples shall be performed by the Contractor and be witnessed by the Inspector. Three pairs of specimens shall be shipped to the approved testing laboratory for testing and three pairs of specimens shall be delivered to the Engineer for record purposes.
  - 2. Specimen sizes shall be of the minimum size required by the laboratory accepted by shop drawing review and shall not be less than: 1) 5-inches wide by 20 times the specimen thickness long for flexural testing; and 2) 10-inches long and 7-inches wide for tensile testing.
  - 3. The Engineer may, at their discretion, require that the Contractor remove two samples from the installed CIPP at locations designated by the Engineer. The opening produced from the sample shall be repaired in

accordance with the manufacture's recommended procedures at no additional cost to the District.

4. The laboratory results shall identify the test sample location as referenced to the nearest manhole and station. The approved laboratory shall return formal test results to the Contractor, with an original copy to the Engineer. If properties tested do not meet minimum requirements, the CIPP shall be repaired or replaced by the Contractor, at no additional cost to the District.

### **13 POST INSTALLATION INSPECTION**

All CIPP sample testing and repairs to the installed CIPP, as applicable, shall be completed, before Final Completion, meeting the requirements of this Specification Section and documented in written form.

The Contractor shall perform a detailed CCTV inspection in accordance with ASTM standards, in the presence of the Inspector after installation of the CIPP and reconnection of the lateral service connections. The post-installation CCTV inspection shall be performed in a dry pipe. The finished CIPP shall be continuous over the entire length of the installation and shall be free of significant visual defects, damage, deflection, holes, leaks and other defects.

The data shall note the inspection date, location of all reconnected lateral sewers, debris, as well as any other defects in the CIPP, including, but not limited to, gouges, cracks, bumps, or bulges. Immediately prior to conducting the CCTV inspection, the Contractor shall thoroughly clean the newly installed CIPP removing all debris and buildup that may have accumulated.

Bypass pumping or plugging from the upstream manhole shall be maintained to minimize sewage from entering the line during the inspection. In the case of bellies in the CIPP, the sewer shall be cleared of any standing water to provide continuous visibility during the inspection.

Where leakage is observed through the wall of the CIPP, the Contractor shall repair or replace CIPP as required in Section 2.7 of this Specification.

Wrinkles in the finished CIPP that cause a backwater of 1-inch or more or reduce the hydraulic capacity of the CIPP are unacceptable and shall be removed and repaired by the Contractor at the Contractor's expense.

## **1.4.27 CURED-IN-PLACE MANHOLES**

### **1 GENERAL**

The liner bag shall be composed of five layers composed of E glass fiberglass, polyester felt, and a flexible non porous PVC water and gas shield membrane. The flexible non-porous PVC water and gas shield shall be embedded between the structural layers of epoxy-fiberglass to guard against nicks, tears and damage to the gas protection membrane.

The pre-saturated weight of the liner bag materials shall comply with Table 1 below.

**TABLE 1**  
**MINIMUM PHYSICAL PROPERTIES**

MH Depth (feet)	Outside Fiberglass Weight (oz)	Inside Felt	PVC Inner Barrier	Inside Felt	Inside Fiberglass Weight (oz)	Min. Total Composite Weight (oz)
>10	12		20 oz		12	44
>15	18		20 oz		18	56
>20	24		20 oz		24	68

The design table above is intended as a general manhole guide for the minimum weights of the liner bag materials at various depths. This is not intended to limit the liner manufacturer's and authorized installer's judgment to recommend the use of a heavier weight fiberglass liner materials for unusual conditions identified in the structure during the pre-manufacturing measurement and inspection. Any recommended increase in the liner thickness approved by the Engineer shall not affect the warranty requirement.

**2 REINFORCED ANGLE POINT BETWEEN THE MAINTENANCE HOLE WALL AND BASE**

The angle point between the maintenance hole wall and the base shall be reinforced with at least two extra layers of fiberglass and shall have a minimum completed composite thickness of six layers of fiberglass each with a minimum weight as specified in Table 1.

**3 EPOXY RESIN**

The modified epoxy resin shall be a two component 100% solids no VOC resin. The resin and catalyst shall be pre-measured at the factory and shipped in separate color-coded part A and B pails. The resin shall bond to the existing manhole brick or concrete substrate.

**1.5 MATERIALS**

**1.5.1 GENERAL**

All materials not conforming to the requirements specified herein shall be considered defective and all such materials, whether in place or not, shall be rejected and shall be removed immediately from the site of the work unless otherwise permitted by the Engineer. No rejected material, the defects of which have been subsequently corrected, shall be used until approved in writing by the Engineer.

**1.5.2 VITRIFIED CLAY PIPE**

**1 GENERAL**

All vitrified clay pipe and fittings shall be of one class designated extra strength, of the best quality, vitrified, homogenous in structure, thoroughly burned throughout their entire thickness, impervious to moisture, sound and free from cracks, checks, blisters, broken extremities or other imperfections, and shall give a metallic ring when struck with a hammer. Pipe shall be bell and spigot pipe or other approved joining method unless otherwise specified. All pipe and special fittings manufacture shall comply with the applicable sections of the District Master Specifications.

**2 IN-PLANT TESTING**

Testing shall be in accordance with the applicable section of the District Specifications. In lieu of the tests being witnessed by a certified testing laboratory approved by the Engineer for pipe sizes 15 inches and smaller, the Contractor may furnish the Districts a letter from the manufacturer stating that all prescribed tests have been made and the pipe meets all requirements of the Master Specification.

In pipe sizes greater than 15-inch diameter, a certified testing laboratory approved by the Engineer shall be employed by the Contractor for specified testing.

**3 CAUSE FOR REJECTION**

The following imperfections in a pipe or special fitting shall be considered injurious and cause for rejection without consideration of the test results submitted as specified above:

***Cracked Pipe***

A single crack in the barrel of the pipe, extending through the entire thickness, regardless of the length of such crack; a single crack which extends through one-fifth of the barrel thickness and is over 3-inch long; any surface fire crack which is more than 1/32-inch wide at its widest point.

***Surface Imperfections***

Surface imperfections such as lumps, blisters, pits or flakes on the interior surface of a pipe or fitting.

***Socket Out-of-Round***

Bore or socket of the pipe that varies from a true circle more than 3 percent of its nominal diameter.

### ***Straight Pipe Fitting***

The pipe fitting designated to be straight, but deviates from a straight line more than 1/8-inch per lineal foot. The deviation shall be measured from a straight edge at a point midway between the ends of the pipe.

### ***Broken Pipe***

A joint of pipe with a piece broken from either the socket or spigot end.

### ***Foreign Matter Fused to the Pipe***

Pipe joints that have tramp clays, grog or other foreign matter fused permanently to the exterior or interior surface of the pipe or fittings.

### ***General Soundness of Pipe and Joints***

The pipe that does not give a metallic ring when struck with a hammer where joint of pipe is placed in a vertical position.

## **4 JOINTS**

All vitrified clay pipe and fittings shall be furnished with bell and spigot Type G compression joint or where plain end pipe is to be used Type C joint. For pipe sizes of 12 inches and smaller, Type D joint may be used.

### ***Type "C" Joints (Mortar Sealed Rubber Sleeve Couplings for Plain End Clay Pipe)***

Each coupling shall consist of a circular rubber sleeve, two stainless steel compressing bands, and optional pre-fabricated housing to form the required mortar seal of the coupling.

Each coupling shall bear the manufacturer's brand name or trademark.

The housing to form the mortar seal shall be shaped to provide the minimum thickness of mortar cover over the coupling and specified in the following table.

Pipe Diameter		Thickness	
(inch)	(mm)	(inch)	(mm)
4	(102)	3 / 4	(19)
6	(152)	3 / 4	(19)
8	(203)	1	(25)
10	(254)	1	(25)
12	(305)	1-1 / 2	(38)

(larger sizes as specified on the Plans)

The circular rubber sleeve shall have a projecting rib to act as a cushion between the abutting ends of the pipes or fittings. The sleeve shall be made of virgin

rubber compounded with suitable antioxidants formulated so as to resist acids, alkalis, solvents, and greases encountered in domestic or industrial waste sewage.

When tested in accordance with ASTM D 412, the material shall have a tensile strength of not less than 1200 tested psi and in elongation of not less than 400 percent. When tested in accordance with ASTM D 395, Method B, the material shall have a compression set at constant deflection of not more than 35 percent of the original deflection. The tensile strength and percentage of elongation shall be reduced not more than 25 percent and the compression set increased not more than 5 percent when subject to the accelerated aging test in ASTM D 572 for 24 hours.

The stainless steel compressing bands and tightening devices shall be fabricated from ASTM Type 300 stainless steel and shall be capable of producing 35 percent compression in the sleeve when tightened in place on the joint. Mortar consisting of one part Portland Cement and three parts sand shall be used for sealing in the rubber sleeve coupling. Water shall be added to the mortar mixture to produce a workable grout mortar.

The assembled pipe joints, without mortar cover shall be tested in the laboratory and shall not leak when subject to an internal hydrostatic pressure of 10 psi for a period of 5 minutes or when the joint is deflected 2 degrees during the test.

***Type “D” Joints (Rubber Sleeve Coupling) with Shear Ring for Plain End Clay Pipe)***

The coupling shall consist of a circular rubber sleeve of natural or synthetic rubber or rubber-like material, two stainless steel bands with suitable tightening devices and corrosion resistant shear ring. The sleeve shall be resistant to chemicals and bacteria, and the joint shall meet all the requirements of ASTM C 425, except that the bands shall be made of stainless steel only.

***Type “G” Joints (Polyurethane)***

General:

The type “G” Joint shall consist of polyurethane elastomer sealing components, one bonded to the outside of the spigot and the other bonded to the inside of the socket. The sealing components shall be shaped, sized, bonded, and cured to uniform hardness so as to form a tight seal of the joint when assembled. The sealing components shall resist attack by bacteria and chemicals or combinations of chemicals normally present in domestic or industrial sewage.

The configuration of the jointing system determines the necessary physical properties of the polyurethane joint material. The columns of values in the table below represent properties of polyurethanes which, in conjunction with specific joint configurations, will provide acceptable jointing systems.

Polyurethane Sealing Components:

The polyurethane sealing components material shall comply with the requirements described in this subsection. The number of samples to be tested shall be designated by the Engineer.

Prior to testing, polyurethane test specimens shall be conditioned in a mechanical convection oven for 7 days at 110 + 5 degrees F (43 + 3 degrees C and cooled in a desiccator for 3 hours at 75 + 5 degrees F (24 + 3 degrees C).

Polyurethane material is acceptable for a jointing system when properties are in conformance with either column of values listed in the following table:

<b>Property</b>	<b>Values</b>	<b>Test Method and Conditions</b>
Tensile strength, psi (kPa) min.	350 (240) 600 (4140)	ASTM D 412 DIE C, 75 ± 5 F (24 ± 3 C)
Elongation, % min.	70 70	(Same as above)
Compression set, percent Max.	3 3	ASTM D 395, Method B, 24 hours, 75 ± 5 F (24 ± 3 C)
Shore durometer	Not less than value designated for the joint design by the manufacturer	ASTM D 2240, Type A, 5-second reading, 32 to 80 F (0 to 27 C)
Water Absorption, percent max. (Wt gain)	3.5 3.5	ASTM D 570, after immersion for 28 days at 75 ± 5 F (24 ± 3 C)
Volatile loss, percent max. (Weight loss)	1 1	After 28 days in mechanical convection oven at 150 ± 3 F (66 ± 2 C)
Adhesive strength, psi (kPa) min.		
Original	350 (240) 350 (2410)	Before immersion in accordance with Note 1
Final	250 (1720) 250 (1720)	After immersion in water at 75 ± 5 F (24 ± 3 C) in accordance with Note 1

Property	Values		Test Method and Conditions
Chemical resistance (see Notes 2 & 4)			
Weight changes, percent max.	1.5	1.5	After exposure to each of the chemical environments for 112 days as described in Notes 2 & 4
Tensile strength, Psi (kPa) min.	260 (1790)	450 (3100)	
Shore durometer, Change max.	± 15	± 15	
Compression set, percent max.	5	5	
Bacteriological resistance (see Notes 3 and 4)			
Weight change	2	2	After exposure to bacteriological environment for 112 days as described in Notes 3 & 4
Tensile strength, psi (kPa) min.	290 (2000)	500 (3450)	
Shore durometer  Before reconditioning, Loss max.	15	15	
After reconditioning, Change max.	5	5	
Compression set  Before reconditioning, percent max.	3	3	

Property	Values	Test Method and Conditions
After reconditioning, percent max.	3                  3	

NOTES:

1. Adhesion test specimens shall be clay blocks 1/2-inch (13-mm) thick and 1-inch (25-mm) square of the same composition of materials and fired at same vitrifying temperatures as sewer pipe.

The clay block shall be placed flat in the center of a mold 7-inch (178-mm) long, 1-inch (25-mm) wide, and 1/2-inch (13-mm) deep. The edges of the clay block at right angles to the longitudinal axis of the form shall be coated with the adhesive and the form on each side of the block shall be filled to a depth of approximately 1/4-inch (6-mm) with the sealing component compound. Curing of this test specimen shall simulate the curing process at the pipe manufacturing plant.

At the end of the immersion period, samples shall be removed, surface dried, and immediately pulled in tension at the rate of 20 inches (508 mm) per minute to determine the final tensile strength of the bonded interfaces. The specimens retained for controls shall be pulled at the same time to determine the original tensile strength of the bonded interface.

2. Exposure environments for chemical resistance tests are as follows:

<u>Chemical</u>	<u>% Concentration</u>
Sulfuric Acid	20*
Ammonium Hydroxide	5*
Sodium Hydroxide	5* (Buffered to pH 10 with Sodium bicarbonate)
Ferric Chloride	1*
Nitric Acid	1

\*Volumetric % of concentrated C.P. grade reagents

At the end of the exposure period, specimens shall be reconditioned before testing by the same method described above for conditioning.

3. The bacteriological resistance immersion test solution shall be prepared with a 5-day BOD of not less than 700 ppm maintained under anaerobic conditions at 75 + 5 degrees F (24 + 3 degrees C) for the duration of the test. At the end of the exposure period, test specimens shall be washed and then reconditioned before testing by the same method described above for reconditioning.

4. During the 112-day exposure period interim tests shall be performed at 28-day intervals and if failure occurs, testing shall be terminated, and the sample shall be considered as failing the entire test.

## **5 SADDLE CONNECTION**

Use of PVC or clay saddle connections will be permitted in special situations and shall not be constructed without prior District approval. All debris shall be kept out of the sewer, the pipe reach cut-into shall be cleaned and balled if necessary, as directed by the District Representative. Prior to installation, the pipe shall be cleaned and sharp edges must be removed. The saddle gasket should be positioned over the pipe with the locating ring inside the cored hole. The side clamps can be placed and tightened once the saddle is pressed firmly against the pipe. The clamps should be tightened to manufacturer recommended torque.

### **1.5.3 DUCTILE IRON PIPE**

#### **1 GENERAL**

Use of ductile iron pipe shall be approved by the District. All ductile iron pipe shall conform to the requirements of AWWA C151/and shall be fusion bonded epoxy lined. Buried pipe shall be provided with anodic protection, joint bonding, and test stations. Exposed pipe shall be coated with a two-part amine cured epoxy, minimum 10 mils dry film thickness, topped with a polyurethane color coat, gray in color. Buried pipe shall be minimum Class 150 pressure class. Exposed pipe shall be minimum Class 53 thickness class.

#### **2 JOINTS**

Joint types shall be as follows:

##### ***Buried Pipe***

- Use restrained joints where thrust restraint is needed rather than thrust blocks.
- Rubber gasket slip-on shall conform to AWWA C111/A21.11.
- Mechanical joint fittings shall be in accordance with AWWA C111/A21.11.

##### ***Above Grade Pipe***

Flange fittings shall conform to ANSI B16.1. Bolts shall conform to ANSI B16.1, except that flanges shall have Type 316 stainless steel bolts and nuts except in air-conditioned spaces.

## **1.5.4 PVC GRAVITY PIPE**

### **1 GENERAL**

Use of PVC for main line sewers on industrial and commercial installations will be permitted only where approved, in advance, by the District.

### **2 PIPES AND FITTINGS**

Pipe, fittings, couplings, and joints shall be in conformance with the size, material and performance requirements of ASTM D3034, Standard Dimensional Ratio (SDR) 35, Dimension Ratio (DR) 14 and DR 18 and shall have gasketed joints.

Pipe and fittings shall be made of PVC plastic having a cell classification of 12454 as defined in ASTM D1784. All pipe shall be of solid wall construction with smooth interior and exterior surfaces.

Pipe Marking: All pipe, fittings, and couplings shall be clearly marked at an interval not to exceed 5-feet as follows:

- Nominal Pipe Diameter
- PVC cell classification
- Company, plant, shift, ASTM, SDR and date designation.
- Service designation or legend

### **3 INSTALLATION**

Pipes which are not installed within 120 days of the latest test shall not be used without prior approval from the District.

The socket and spigot configurations for fittings and couplings shall be compatible with those used for the pipe. Socket and spigots must be installed per manufacturing information and must follow insertion markings.

## **1.5.5 PRECAST MANHOLES**

### **1 GENERAL**

All precast manhole shafting, cones and flat tops shall be free from cracks, chips, surface imperfections and shall be capable of producing a watertight unit. Manhole shafting shall not be installed with steps.

## **2 UNLINED MANHOLES**

Precast manholes shall conform to size, shape, form, and details shown on the Standard Drawings. Concrete for precast units shall be Class "D" concrete. The precast shafting and cones shall meet the strength requirements for ASTM C478 "Standard Specification for Precast Reinforced Concrete Manhole Sections". Design and manufacturing shall be based on H-20 loading.

## **3 LINED MANHOLES**

Manholes designated as "lined", on pipe over 21", on segments with 10% slope or greater, with pressurized laterals, drop manholes and other manholes as determined by the Engineer, shall be lined with polyurethane liner. All materials and installation shall be in accordance with the specification and notes and details shown on Standard Drawings.

### **1.5.6 POLYMER CONCRETE MANHOLES**

#### **1 GENERAL**

Facility Quality Control shall be maintained by adhering to ISO 9001:2015 for manufacturing. All fabricators shall be ISO 9001:2015 Certified. All fabrication shall take place in an all-polymer concrete fabrication facility. At no time shall the polymer concrete fabrication facility share the facility with a cementitious precast product production facility.

Fabricator shall also provide references of 5 previous projects in the last 5 years performed with both owner and contractor for reference and review by owner. Polymer concrete shall be cast in a polymer only facility and shall not be manufactured in a cementitious concrete facility.

#### **2 MATERIAL**

Polymer manhole bases is not permitted. Manhole bases shall be poured in place concrete.

Polymer concrete manhole sections, cast-in-place base sections and related components shall be in conformance with requirements of ASTM C 478.

Use various lengths of polymer concrete manhole sections in combination to provide correct height with the fewest joints.

Provide tops to support with HS-20 cast iron or composite frame covers or hatches, as indicated on drawings.

Polymer Concrete Mix Design shall consist of thermosetting resin, sand, and aggregate. No Portland cement shall be allowed as part of the mix design matrix.

Use acid resistant reinforcement (FRP Bar) in accordance with ACI 440.1R-06 for polymer concrete design.

Each polymer concrete manhole component shall be free of all defects, including indentations, cracks, foreign inclusions and resin starved areas that, due to their nature and degree or extent, detrimentally affect the strength and serviceability of the component part.

Manhole joints shall be assembled with a bell/spigot or shiplap butyl mastic or gasketed joint so that on assembly, manhole base, riser and top section make a continuous and uniformly watertight manhole.

All materials needed for grouting and patching shall be a polyester mortar compound provided by the manufacturer or an approved equal by the manufacturer.

Polymer concrete manholes shall be manufactured by Armorock LLC, or equal.

### **1.5.7 GRADE RINGS**

Grade rings shall be the size and quantity as indicated in the Standard Drawings. Grade rings shall be free from cracks, chips or excessive roughness as determined by the Inspector.

Individual concrete grade rings for extensions shall be a maximum of 6 inches high and shall be approved by the Engineer before installation. Total height of stacked grade rings shall be limited to a maximum of 24 inches.

### **1.5.8 MANHOLE FRAME AND COVER**

Manhole frame and cover sets shall be of the types and size indicated in the Standard Drawings unless otherwise indicated on the Plans.

Manhole frame and cover sets installed in an intersection shall be bolted.

All manhole frame and cover sets shall have the facility identification on the underside of lid and on frame. All castings shall comply with ASTM A48 "Standard Specification for Gray Iron Castings", Class 35 B cast iron.

Composite frame and cover are only allowed in residential areas and only as approved by the Engineer. Composite frame and cover shall be tested to be able to sustain a minimum breaking load of 2,000 pounds using a test bar as recommended by manufacturer. Composite manhole frame and cover shall be manufactured by EJ Co. 3800 series or equal.

Castings for frame and cover sets shall be designed for H-20 loadings. Before leaving the foundry, all castings shall be thoroughly cleaned and subjected to a hammer

inspection, after which they shall be painted with a 60-mil minimum thickness of coal-tar epoxy. Covers shall have reinforced gussets on the underside.

Each cover shall be ground or otherwise finished so that it will fit in its frame without rocking. Frames and covers shall be match-marked in sets before shipping to site.

New manholes shall be built with covers set at 12 to 16 inches from the top of the cone.

### **1.5.9 EPOXY RESIN**

All saddle connections and approved repair work to District sewer mains shall be accomplished with one of the following epoxy resins:

SewerGard No. 210X Epoxy Lining System as manufactured by Saueresin;

Epoxy Coating S-301 as manufactured by Warren Environmental;

EPON 828 as manufactured by Hexion.

### **1.5.10 PORTLAND CEMENT CONCRETE**

#### **1 GENERAL**

All Portland cement concrete shall conform to the requirements of ASTM C150 and shall be Type II, III or V.

#### **2 TYPES**

- Type II Standard ASTM Designation 15.
- Type III High Early Strength Type.
- Type V Sulfate Resistant Cement Type.

#### **3 Class of Concrete**

	A	B	C	D
Compressive strength at 28 days (psi)	3500	3250	2500	4500
Cement Factor-Minimum (Sacks/cu. Yd.)	6.0	5.5	4.5	7.0
Water Cement Ratio-Max. (gallons/sacks)	6.0	6.5	7.0	5.6

#### **4 ADMIXTURES**

No admixtures shall be used without written consent of the Engineer. Calcium Chloride, if approved, shall be used to a maximum dosage of 2 pounds per 100 lbs.

### **1.5.11 STEEL CASING OR OPEN TRENCH CASING**

#### **1 CASING SEALS**

Casing seals shall be 1/8-inch-thick synthetic, rubber, designed to fit snugly around pipe and casing. Casing seals may be one piece with no field seams or the wrap-around style to facilitate installation after the casing and carrier pipe are already installed. Seamless style is preferred. Bands and hardware for attachment to pipe and casing OD shall be stainless steel.

#### **2 GROUT**

Exterior of Casing: Grout shall consist of an 8-sack sand slurry (for Jacked Casing only).

Interior of Casing (between carrier pipe and casing): Grout shall consist of cellular concrete as manufactured by Cell-Crete Corporation. The cellular concrete shall have minimum compressive strength of 100 psi.

#### **3 GROUT CONNECTIONS**

The Contractor shall provide 1-inch diameter threaded steel half-couplings on the inside of the casing pipe at the locations, spacing and orientation called for in the Standard Drawings. Unless noted otherwise in the plans or specifications, grout connections on the casing pipe shall be provided near the top of the casing. Longitudinal spacing between grout connections along the axis of the casing pipe shall be 60 inches. This spacing may be decreased to provide more frequent grouting, but in no case shall the spacings shown on the drawings or specifications be exceeded.

### **1.5.12 CIPP**

#### **1 FABRIC AND PRELINER TUBE**

Upon delivery, the outside layer of fabric tube shall be plastic coated with a material that is compatible with the resin system. Make allowance for circumferential stretching during inversion. Use a preliner tube sized to fit host pipe. Preliner tube shall be composed of 3-ply laminate sheet combining two layers of polyethylene film and high strength nylon cord grid formed into a tube sized to fit host pipe and shall be continuous for the entire length of host pipe.

The fabric tube shall consist of one or more layers of absorbent non-woven felt fabric and meet the requirements of ASTM F1216, ASTM F1743, and

ASTM D5813. The fabric tube shall be capable of absorbing and carrying resins, constructed to withstand installation pressures and curing temperatures and have sufficient strength to bridge missing pipe segments, and stretch to fit irregular pipe sections. The Contractor shall submit certified information from the felt manufacturer on the nominal void volume in the felt fabric that will be filled with resin.

The wet-out fabric tube shall have a uniform thickness and excess resin distribution that when compressed at installation pressures will meet or exceed the design thickness after cure.

The fabric tube shall be manufactured to a size and length that when installed will tightly fit the internal circumference, meeting applicable ASTM standards, of the original pipe. Allowance shall be made for circumferential stretching during installation. The tube shall be properly sized to the diameter of the existing sewer and the length to be rehabilitated and be able to stretch to fit irregular sewer sections, bends and fittings as shown on the Plans. The Contractor shall determine the minimum tube length necessary to effectively span the designated run between manholes. The Contractor shall perform pre-installation measuring of each pipe reach between Manholes. The Contractor shall perform two measurements, the 12-6 o'clock measurement and 3-9 o'clock measurement before the liner is ordered to ensure liner fits the pipe without wrinkling. The Contractor shall verify the lengths in the field prior to impregnation of the tube with resin, to ensure that the tube will have sufficient length to extend the entire length of the run. The Contractor shall also measure the inside diameter of the existing sewers in the field prior to ordering the CIPP liner so that the CIPP can be installed in a tight-fitted condition.

The outside and/or inside layer of the fabric tube (before inversion/pull-in, as applicable) shall be coated with an impermeable, flexible membrane that will contain the resin and facilitate, if applicable, vacuum impregnation and monitoring of the resin saturation during the resin impregnation (wet-out) procedure.

No material shall be included in the fabric tube that may cause de-lamination in the cured CIPP. No dry or unsaturated layers shall be acceptable upon visual inspection as evident by color contrast between the felt fabric and the activated resin containing a colorant.

The wall color of the interior surface of CIPP after installation shall be a light reflective color so that a clear detailed examination with CCTV inspection equipment may be made. The hue of the color shall be dark enough to distinguish a contrast between the fully resin saturated felt fabric and dry or resin lean areas.

Seams in the fabric tube, if applicable, shall meet the requirements of ASTM D5813.

The outside of the fabric tube shall be marked every 5-feet with the name of the manufacturer or CIPP system, manufacturing lot and production footage.

The minimum length of the fabric tube shall be that deemed necessary by the Installer to effectively span the distance from the starting manhole to the terminating manhole or access point, plus that amount required to run-in and run-out for the installation process.

The nominal fabric tube wall thickness shall be constructed, as a minimum, to the nearest 0.5 mm increment, rounded up from the design thickness for that section of installed CIPP. Wall thickness transitions, in 0.5 mm increments or greater as appropriate, may be fabricated into the fabric tube between installation entrance and exit access points. The quantity of resin used in the impregnation shall be sufficient to fill all of the felt voids for the nominal felt thickness.

## **2 RESIN**

The resin shall be a corrosion resistant vinyl ester resin and catalyst system that when properly cured within the tube composite meets the requirements of ASTM F1216 in locations as required on the Plans, the physical properties herein, and those, which are to be utilized in the design of the CIPP for this Project. The resin shall produce CIPP which will comply with or exceed the structural and chemical resistance requirements of this Specification.

The resin shall be a corrosion resistant vinyl ester resin and catalyst system that has previously passed the chemical and corrosion resistance requirements of the Green Book. Evidence of having met the Green Book chemical resistance testing for the proposed system shall be provided as part of the shop drawings.

## **3 STRUCTURAL REQUIREMENTS**

The CIPP shall be designed per ASTM F1216, Appendix X1, for a fully deteriorated gravity sewer condition. The CIPP design shall assume no bonding to the original sewer wall.

The Contractor shall have performed long-term testing for flexural creep of the installed CIPP material. Contractor shall use such testing results to determine the long-term, time dependent flexural modulus to be used in the product design. This is a performance test of the materials (tube and resin) and general workmanship of the installation and curing. A percentage of the instantaneous flexural modulus value (as measured by ASTM D-790 testing) shall be used in design calculations for external buckling. The percentage, or

the long-term creep retention value used, shall be verified by this testing. Retention values in excess of 50% of the short-term test results will not be applied unless substantiated by qualified third party test data. The materials shall be of a quality equal to or better than the materials used in the long-term test with respect to the initial flexural modulus used in the Design.

The layers of the cured CIPP shall be uniformly bonded. It shall not be possible to separate any two layers with a probe or point of a knife blade so that the layers separate cleanly or the probe or knife blade moves freely between the layers. If separation of the layers occurs during testing of field samples, new samples shall be cut from the Work. Any reoccurrence may cause rejection of the Work.

The CIPP material shall conform to the structural properties listed in Table 2.

**TABLE 2**  
**MINIMUM PHYSICAL PROPERTIES**

<u>Property</u>	<u>Test Method</u>	<u>Cured Composite Per ASTM F1216</u>
Modulus of Elasticity	ASTM D790 (short term)	250,000 psi
Flexural Stress	ASTM D790	4,500 psi

The required structural CIPP wall thickness shall be based as a minimum, on the physical properties in Part 2 of this Specification, in accordance with the Design Equations in the appendix of ASTM F 1216, and the following design parameters:

Design Safety Factor	=	2.0
Retention Factor for Long-Term Flexural Modulus to be used in Design ( <i>as determined by Long-Term tests</i> )	=	1% - 50%
Ovality	=	2%
Enhancement Factor, k	=	7
Depth to Groundwater	=	Ground surface
Soil Depth (above invert)	=	4 feet to 12 feet
Soil Modulus	=	700 psi
Soil Density	=	120 pcf
Live Load	=	H20

Design Condition

= Fully deteriorated

Any layers of the tube that are not saturated with resin prior to insertion into the existing sewer shall not be included in the structural CIPP wall thickness computation.

The Contractor shall submit a design thickness based on the load parameters listed herein, calculated per ASTM F1216. The use of a flexural modulus value higher than the minimum shall be supported by third-party independent testing that has been performed for a period of 1 year. High strength resins and/or reinforced tube materials may be used provided they meet all requirements listed in this Specification section. The thickness design calculations and third-party test results shall be submitted to the Engineer to support the submitted design thickness. The Contractor shall allow sufficient additional thickness to compensate for resin migration, shrinkage, or other installation anomalies so that the installed CIPP meets the minimum design thickness of 4 millimeters.

#### **4 END SEALS**

The beginning and end of the new pipe liner shall be sealed to the host pipe with a hydrophilic epoxy or other material end seal. Hydrophilic end seals for use at non-pressure manholes shall be epoxy or other material. The end seals shall be compatible with the lining material and host pipe and shall provide a watertight seal. End seal shall be in accordance with Green Book 500-1.1.7 and submitted with the CIPP shop drawings for review and acceptance.

### **1.6 TESTING**

#### **1.6.1 GRAVITY SEWERS**

##### **1 AIR TESTING**

All sewers shall be air-tested. Testing shall take place only after certification that the compaction requirements and sewer cleaning requirements have been met. Any recompaction over the sewer or repair of the sewer shall invalidate previous testing in the section of pipe involved.

Each section of pipe between two successive manholes shall be tested by plugging all pipe outlets with suitable test plugs. Air shall be slowly added until the internal pressure is raised to 4.0 psig. The compressor used to add air shall have a pressure relief valve set at 5 psig to assure that at no time the pressure becomes greater than 5 psig. The internal pressure of 4 psig shall be maintained for at least three minutes to allow air temperature to stabilize. After the three minute stabilization period, the air supply shall be disconnected and the pressure allowed to decrease to 3.5 psig. The time required for the air pressure to drop from 3.5 psig to 2.5 psig shall be measured and compared to the times shown below:

Pipe Size (Inch)	Time In (Minute)
8	4
10	5
12	6
15	7
18	9
21	10
24	11

If the pressure drop from 3.5 psig to 2.5 psig occurs in less time than the above values, the test shall be deemed failed and the pipe shall be repaired and, if necessary, replaced or relaid until the joints and the pipe hold air under this test.

## **2 CLOSED CIRCUIT TELEVISION (CCTV) VIDEO INSPECTION**

The Design Engineer working for the District or consulting engineer under contract with the District for performing the design of a new or refurbished District gravity sewer is responsible for scheduling a closed circuit television (CCTV) video inspection of the appropriate existing District gravity sewer serving the sewer shed for which a new or refurbished gravity sewer will serve during the preliminary design phase or early in the final design phase of the work. The Design Engineer or consulting engineer will thoroughly research and identify all local and District trunk sewers to properly establish the sewer shed boundaries for any given job or portion of the District sewerage system.

All District local, sub-trunk and trunk sewers involved with existing sewage flow to be conveyed by the new sewer or refurbished sewer under the design job will be CCTV video inspected as part of the design. The Design Engineer or consulting engineer will collect or identify all appropriate pages or plans of the actual District "record drawing" or "as-built" plans representing all sections of existing sewer pipelines to be CCTV video inspected.

The Design Engineer or consulting engineer shall give the District staff person responsible for coordinating the design work a minimum of fourteen (14) calendar days advance notification for the District to properly schedule the desired CCTV video inspection. The District O&M Department will physically arrange for and oversee one of the District contracted CCTV video inspection crews to do the work of performing the CCTV video inspection inside of the appropriately identified District gravity sewers. The District will complete the CCTV video inspection in accordance with the latest District and NASSCO Pipeline Assessment and Certification Program (PACP) standards. The District will share the results of the CCTV video inspection with the Design Engineer or consulting engineer by means of either electronic data or physical submission which may include a flash drive and an accompanying written report.

The Design Engineer or the consulting engineer will verify that the CCTV video inspection performed by the District adequately identifies the appropriate

NASSCO PCAP requirements for pipeline deficiencies in the existing District sewer pipeline which has been identified by the Design Engineer or the consulting engineer. In addition, the Design Engineer or the consulting engineer shall properly identify by reviewing the CCTV video inspection media and accompanying report all incoming connections, house or business laterals, or other local or District sewer connections, all manholes, and any junction or diversion structures in any section of the existing District pipeline shown in the CCTV video inspection media. The Design Engineer or consulting engineer shall be responsible for documenting the condition assessment and location of all pipeline sections, connections and structures associated with the identified existing District sewers and properly use that information in the design of any new or refurbished District sewer.

The Contractor is responsible for scheduling a closed circuit television (CCTV) video inspection with the District for all sections of sanitary sewer pipe installed by the Contractor on the job after the pipe has been installed, backfilled and compacted to grade, tested for leakage, manholes raised to grade, and cleaned, but prior to the final resurfacing of the street or surface directly over the pipe.

The pipe shall be CCTV video inspected involving a CCTV video process by a District contracted CCTV video inspection crew (not by the Contractor), subject to a seven (7) calendar day minimum advance notification to the District by the Contractor such that the pipe is or will be ready for CCTV video inspection on the scheduled advance date. The Contractor must have properly installed, prepared, tested and cleaned the pipe in accordance with District standards. The Contractor must allow the District contracted CCTV video inspection crew and equipment proper access to each manhole on the job to do the video inspection. The District will complete the CCTV video inspection in accordance with the latest District and NASSCO Pipeline Assessment and Certification Program (PACP) standards. The District will share the results of the CCTV video inspection with the Contractor by means of either electronic data or physical submission which may include a USB flash drive and an accompanying written report.

The Contractor and/or the District will verify that the pipe installation by the Contractor meets NASSCO PCAP requirements and is acceptable to the District. Should the CCTV video inspection indicate any faulty or unacceptable (to the District) pipe installation, the Contractor shall make the necessary repairs or replacements satisfactory to the District at the Contractor's expense by a method acceptable to the District/Engineer. Repaired or replaced pipe and/or pipe segments shall be retested and cleaned by the Contractor, and be re-inspected by the District provided CCTV video inspection crew, to the same standards that are required from before, but only after the Contractor has satisfied the District that the pipe is ready for inspection and the date for re-inspection has been scheduled by the Contractor by a seven (7) day minimum advance notification to the District.

All costs for scheduling, preparing for inspection, testing, retesting, installing, reinstalling, repairing, cleaning, re-cleaning or other administrative costs, delays or activities by the Contractor relating to the pipe shall be provided for and paid

by the Contractor at no additional cost to the District, until final acceptance of the pipe by the District is achieved.

## **1.6.2 MANHOLES**

All manholes on new sewers shall be vacuum-tested per ASTM C1244 "Standard Test Method for Concrete Manholes by the Negative Air Pressure (Vacuum) Test Prior to Backfill". Manholes shall be watertight. All leaks shall be repaired as determined by the Engineer.

The manhole, if pressure tested, shall be filled with water to an elevation one foot below the start of the cone section, but to a maximum depth of 20 feet. The water shall stand in the manhole for a minimum of one hour to allow the concrete to reach maximum absorption. After one hour, the Contractor shall refill the manhole to the original depth and the drop in water surface shall be recorded after a period of two minutes for each foot of water depth. The maximum allowable drop in water surface for the period of testing shall be 1/2-inch for each 15 minutes of testing. Repairs shall be made as directed by the Engineer whenever leakage exceeds the limits indicated above. All infiltration shall be stopped prior to vacuum or pressure testing. All joints shall be exposed prior to testing.

## **1.7 SAFETY**

### **1.7.1 EXCAVATIONS**

The Contractor shall comply with all safety ordinances and orders and shall be solely responsible for the safety conditions of the Work.

The Contractors shall submit a detail showing the design or shoring; bracing sloping or other provisions to be made for worker protection from the hazards of caving ground during the excavation of any trench 5 feet or more in depth.

The plan submitted shall be stamped and signed by a Civil or Structural Engineer Registered in the State of California to certify that the plan complies with all OSHA.

The Inspector will not inspect trenches which do not conform to OSHA trench safety standards.

### **1.7.2 CONFINED SPACE OPERATION**

No entry into District's facilities shall take place without first checking for unsafe atmosphere conditions and, if found safe, entry shall be made only with the use of adequate air blowers and safety harnesses attended by a minimum of two men outside the facility. Proper air monitoring shall be in use at all time to monitor for L.E.L., H2S and oxygen deficiency before and during performance of work.

All manholes are defined as Title 8 Permit Required Confined Spaces. The Contractor's attention is directed to the General Industry Safety Orders of the State of California, Article 108, Confined Spaces, Section 5157 (Title 8 of California Code of Regulations, Sections 5167, 5157, and 5158). Manhole entry, if required, shall be conducted in strict accordance with permit required confined space entry regulations. These regulations include, at a minimum: entry permit, trained authorized entrant(s), attendant(s), entry supervisor(s), full body harness (with life line), mechanical retrieval device, continued force air ventilation, continuous air monitoring, communication system (minimum two types), and all other protective equipment that may be required. Work shall be conducted in accordance with all Federal, State, and local laws and regulations. The local fire department may be able to offer services for Confined Space rescue. Contractor shall make any and all arrangements necessary at no additional cost to the District.

### **1.7.3 TRAFFIC CONTROL**

Prior to undertaking the work, traffic control plans shall be submitted to the Agency having jurisdiction of the street for approval. A copy of the plans, the approved permit, and requirement therefore shall be provided to the Engineer.

In no case shall the traffic control be less than that required by the latest Work Area Traffic Control Handbook (WATCH) Manual.

Traffic control shall be in accordance with the latest WATCH Manual and City, County, or California Department of Transportation regulations and based on the speed limits posted in the work zones. Contractor shall apply for all traffic control permits and pay all fees for said permits.

Contractor shall provide all the necessary traffic control equipment and staff to adhere to the regulations set forth by the authority(s) having jurisdiction and in accordance with the traffic control plans that may have been reviewed and approved by said authority(s).

## 2. STANDARD DRAWINGS FOR SANITARY SEWERS

### Table of Contents

<b>Drawing Number</b>	<b>Description</b>
S-1	PIPE INSTALLATION AND PAVEMENT REPLACEMENT
S-2	CONCRETE ENCASEMENT OF PIPE
S-3	VALVE BOX, SURVEY MONUMENT, OR SEWER CLEAN OUT COVER AND FRAME INSTALLATION
S-4	NOT USED
S-5	NOT USED
S-6	SEWER HOUSE LATERAL AT UTILITY INTERSECTIONS
S-7	ANCHOR BLOCK DETAIL
S-8	PIPE INSTALLATION IN CASING
S-9	FIELD CLOSURE FOR VCP PIPES
S-10	POLYMER CONCRETE MANHOLE AND CONCRETE BASE
S-11	COMPOSITE MANHOLE FRAME AND COVER (36" CLEAR OPENING)
S-12	NEW UN-LINED MANHOLE FOR SEWERS
S-13	NEW LINED MANHOLE OVER EXISTING SEWER
S-14	NEW LINED MANHOLE FOR NEW SEWERS
S-15	DROP MANHOLE CONNECTION TO STANDARD MANHOLE
S-16	48" MANHOLE FRAME AND COVER WITH CONCENTRIC 24" COVER
S-17	STANDARD MANHOLE FRAME AND COVER
S-18	BOLTED MANHOLE FRAME AND COVER
S-19	MANHOLE ADJUSTMENT TO GRADE
S-20	GAS FLAP INSTALLATION FOR LINED OR UNLINED MANHOLES
S-21	CORE DRILLED STUB AT EXISTING MANHOLE DETAIL
S-22	DIVERSION STRUCTURE WITH STOP GATE
S-23	REHABILITATION OF PVC LINED MANHOLES
S-24	CUT IN WYE CONNECTIONS
S-25	HOUSE LATERAL CONNECTION TYPICAL
S-26	EXISTING MANHOLE ABANDONMENT

9/1/2022

N:\ECC\DWG\ECC\DWG-2021-002 Sewer Standards Update\300 Engineering\301 CAD\Plansets\S-01.dwg

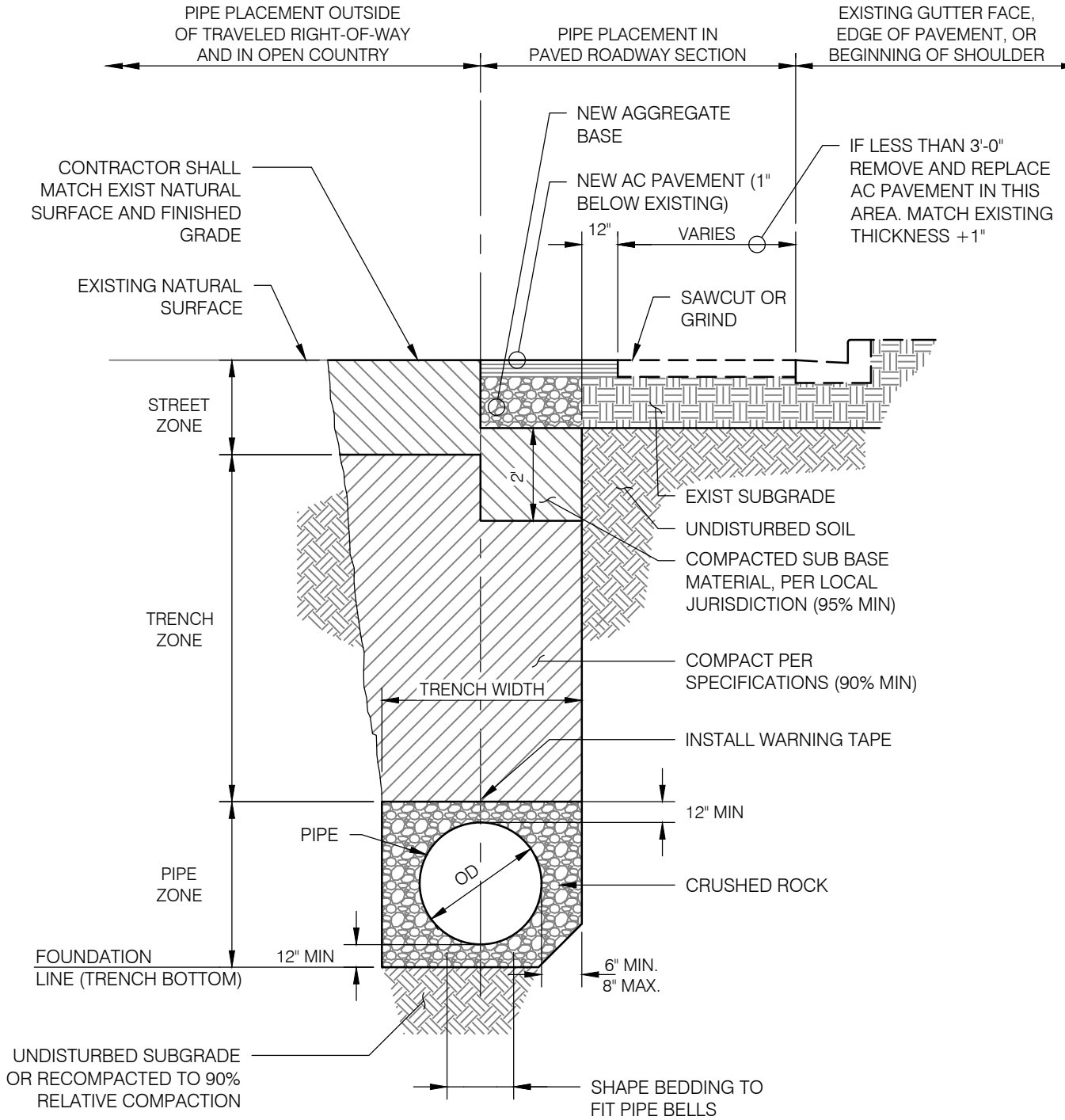

**NOTE:**

1. IF THERE IS A DISCREPANCY BETWEEN THIS SPECIFICATION AND THE LOCAL JURISDICTION, THE LOCAL JURISDICTION TAKES PRECEDENT
2. TRENCH WIDTH, BEDDING AND BACKFILL MATERIALS, COMPACTION PER SPECIFICATIONS SECTION 1.4.21 AND 1.4.22.
3. IF UNSTABLE SOIL IS ENCOUNTERED, THE DISTRICT SHALL DETERMINE OVEREXCAVATION DEPTH AND ADDITIONAL REQUIREMENTS.

NO.	APPROVED	DATE

EAST ORANGE COUNTY WATER DISTRICT  
ORANGE, CALIFORNIA

APPROVED BY *[Signature]* 9/1/2022  
DATE

GENERAL MANAGER *[Signature]* 9/1/2022  
DATE

DISTRICT ENGINEER *[Signature]* 9/1/2022  
DATE

**PIPE INSTALLATION  
AND  
PAVEMENT REPLACEMENT**

NO SCALE  
STANDARD DWG.  
**S-1**

9/1/2022

N:\ECC\WD\EOC\WD-2021-002 Sewer Standards Update\300 Engineering\301 CAD\Plansets\S-27.dwg

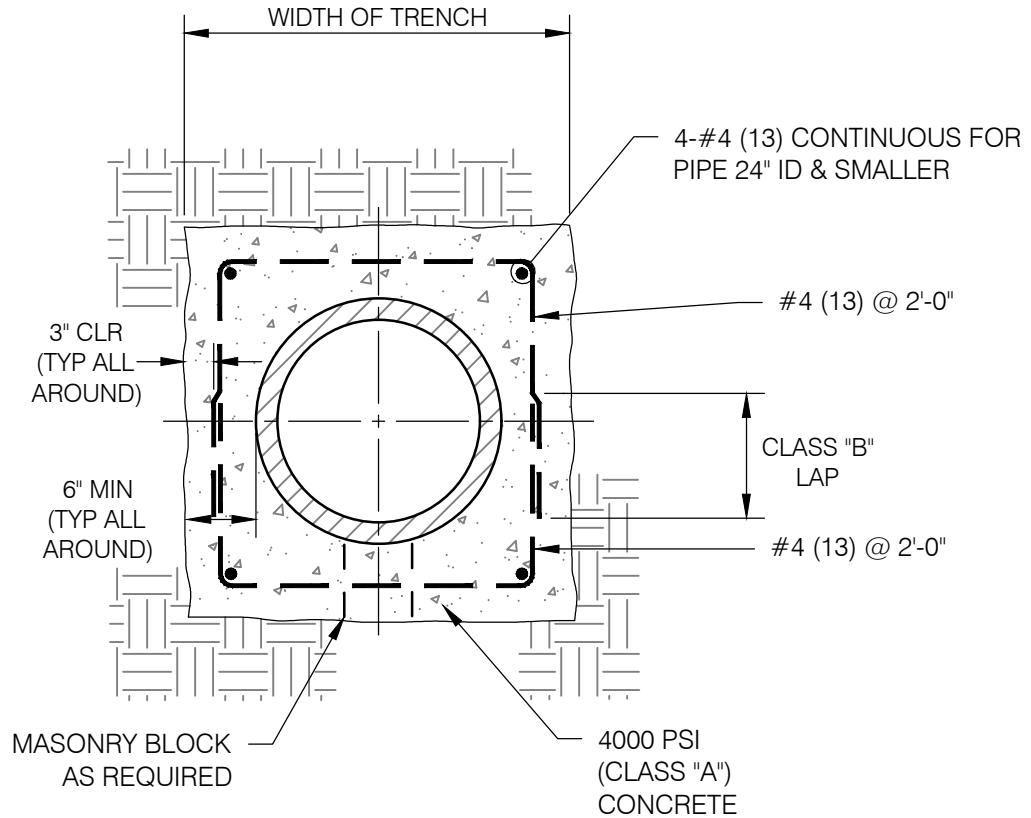

NOTE: ALL CONCRETE FOR ENCASEMENTS SHALL BE 560-C-3250 (CLASS "A").

( ) DENOTES METRIC SYSTEM

			EAST ORANGE COUNTY WATER DISTRICT ORANGE, CALIFORNIA		CONCRETE ENCASEMENT OF PIPE		NO SCALE	
			APPROVED BY <i>[Signature]</i> 9/1/2022				STANDARD DWG.	
			GENERAL MANAGER _____ DATE _____		S-2			
NO.	APPROVED	DATE	DISTRICT ENGINEER <i>[Signature]</i> 9/1/2022					

9/1/2022

N:\EOCWD\EOCWD-2021-002 Sewer Standards Update\300 Engineering\301 CAD\Plansets\S-03.dwg

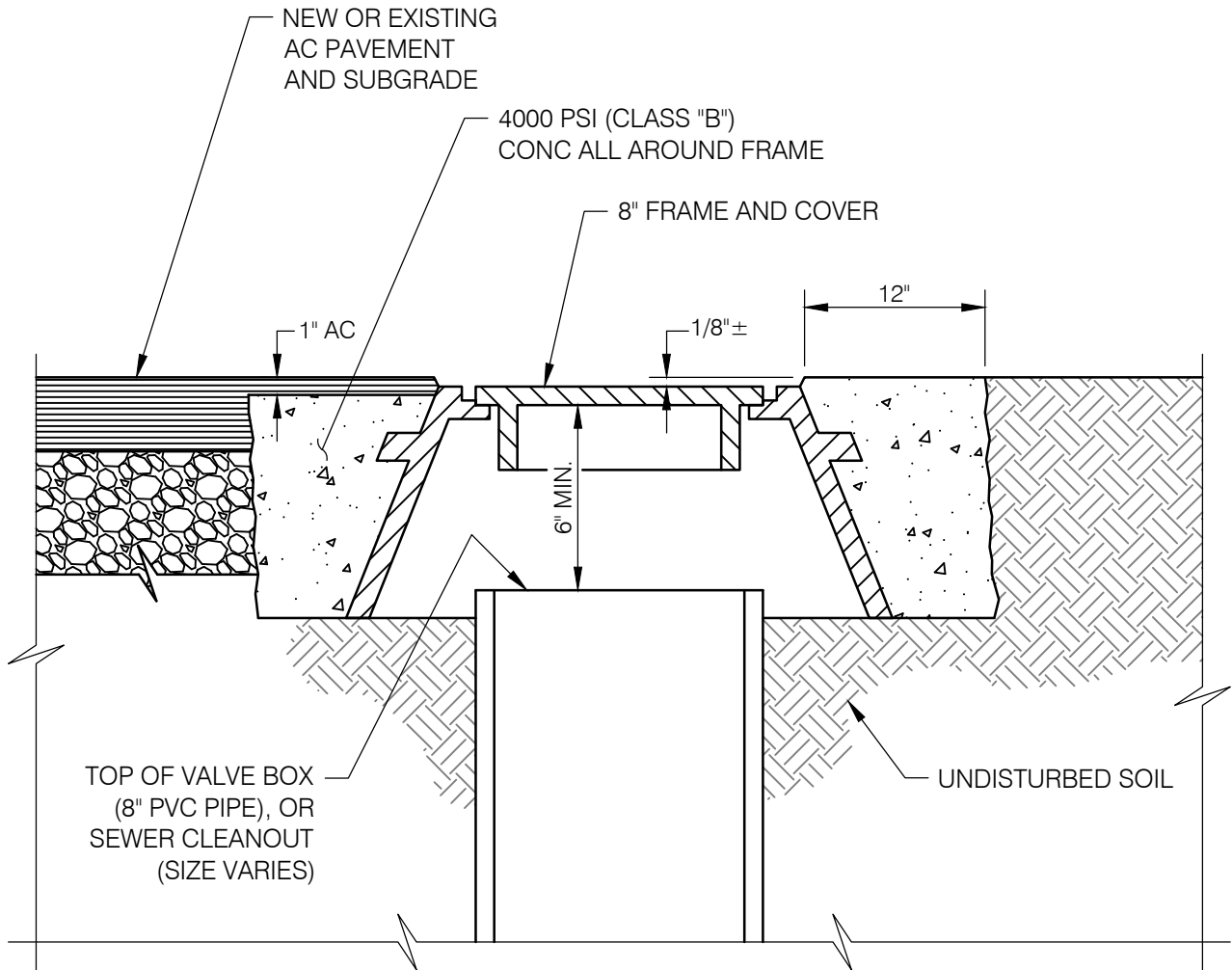

NO.	APPROVED	DATE

EAST ORANGE COUNTY WATER DISTRICT  
ORANGE, CALIFORNIA

APPROVED BY *[Signature]* 9/1/2022  
DATE

GENERAL MANAGER *[Signature]* 9/1/2022  
DATE

DISTRICT ENGINEER *[Signature]* 9/1/2022  
DATE

VALVE BOX, SURVEY MONUMENT,  
OR SEWER CLEAN OUT COVER  
AND FRAME INSTALLATION

NO SCALE  
STANDARD DWG.  
**S-3**

9/1/2022

N:\ECC\WD\EOC\WD-2021-002 Sewer Standards Update\300 Engineering\301 CAD\Plansets\S-06.dwg

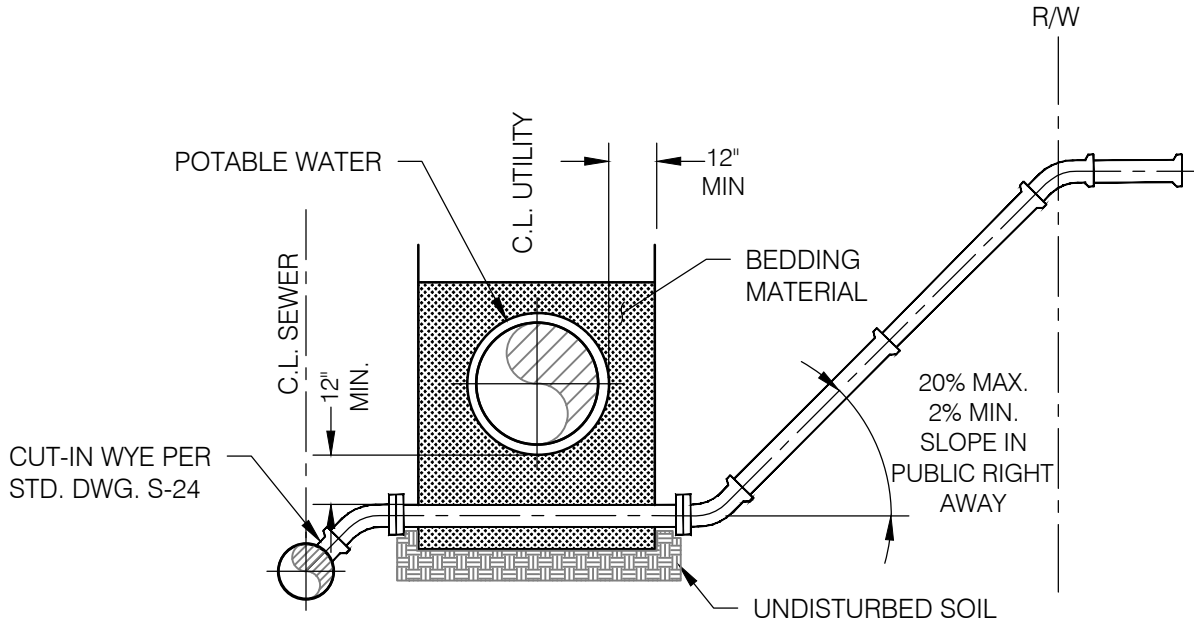

TYPE I

**NOTES:**

1. ANY OTHER PROPOSE DESIGN SHALL HAVE THE DISTRICT ENGINEER'S APPROVAL PRIOR TO THE START OF CONSTRUCTION.
2. MINIMUM SLOPE FOR SEWER LATERAL SHALL BE 1/4" PER FOOT.
3. LATERALS SHALL HAVE A MINIMUM OF 5' OF COVER AT THE PROPERTY LINE.
4. SLOPE GREATER THAN 20% NEED DISTRICT APPROVAL.
5. FOR SEWER LATERALS CROSSING ABOVE WATER LINE REFER TO THE CALIFORNIA WATERWORKS STANDARDS (CALIFORNIA CODE OF REGULATIONS (CCR), TITLE 22).

NO.	APPROVED	DATE

EAST ORANGE COUNTY WATER DISTRICT  
ORANGE, CALIFORNIA

APPROVED BY *[Signature]* 9/1/2022  
DATE

GENERAL MANAGER *[Signature]* 9/1/2022  
DATE

DISTRICT ENGINEER *[Signature]* 9/1/2022  
DATE

**SEWER HOUSE LATERAL AT  
UTILITY INTERSECTIONS**

NO SCALE

STANDARD DWG.

**S-6**

9/1/2022

N:\ECC\WID\EOCWD-2021-002 Sewer Standards Update\300 Engineering\301 CAD\Plansets\S-07.dwg

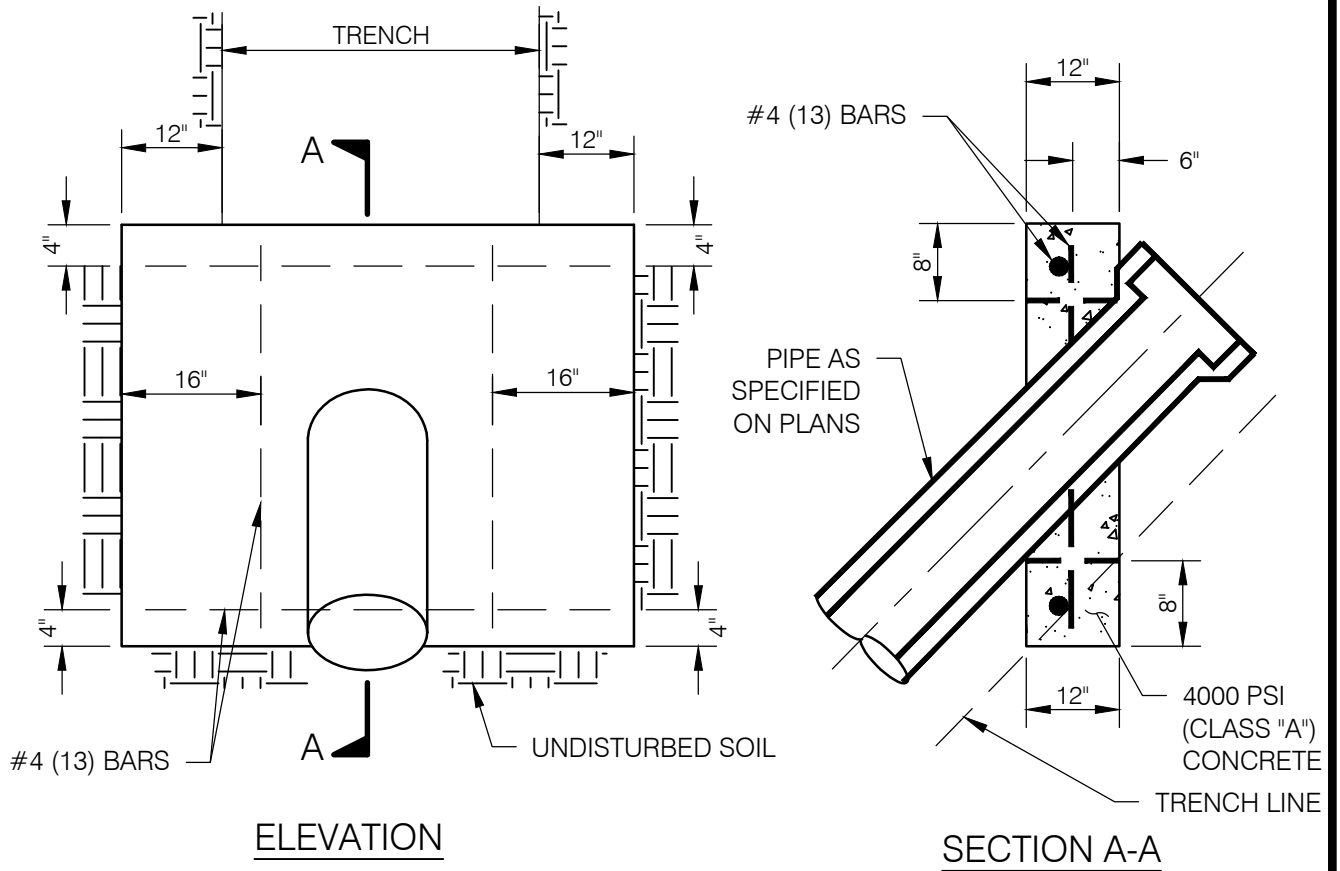

**NOTES:**

1. PIPE ANCHOR BLOCKS SHALL BE INSTALLED ON ALL SEWERS WHERE THE SLOPE EXCEEDS 30%.
2. SPACING SHALL BE 100' ON CENTER WHERE SLOPES ARE 30% TO 50%, 75' ON CENTER WHERE SLOPES ARE 51% TO 70%, AND 50' ON CENTER WHERE SLOPES ARE 71% AND GREATER.

( ) DENOTES METRIC SYSTEM

			EAST ORANGE COUNTY WATER DISTRICT ORANGE, CALIFORNIA		NO SCALE	
			APPROVED BY <i>[Signature]</i>		STANDARD DWG.	
			GENERAL MANAGER		DATE	
			DISTRICT ENGINEER <i>[Signature]</i>		DATE	
NO.	APPROVED	DATE	<b>ANCHOR BLOCK DETAIL</b>			<b>S-7</b>

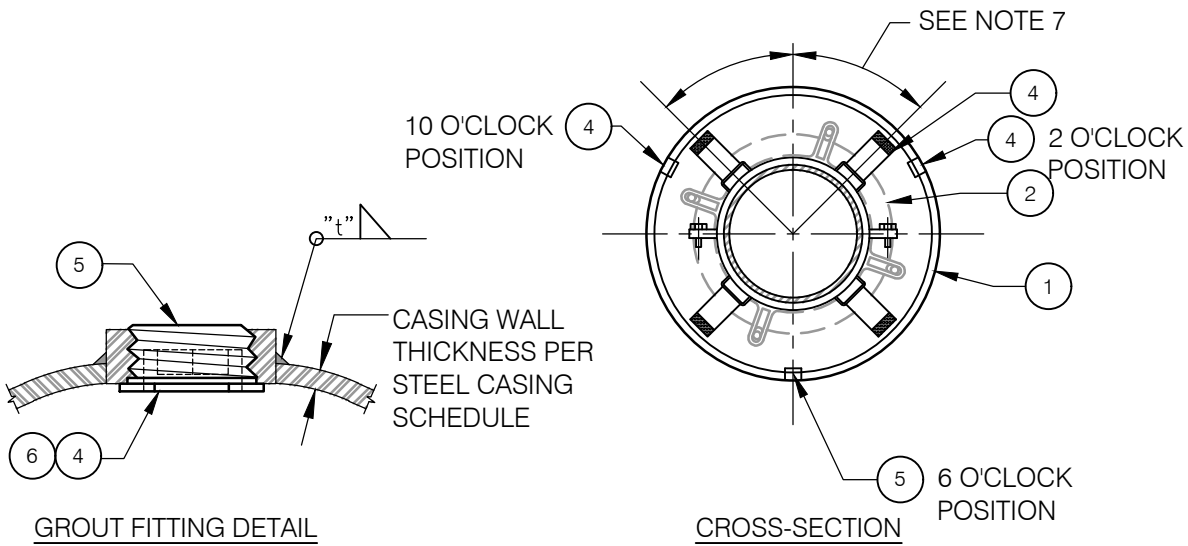
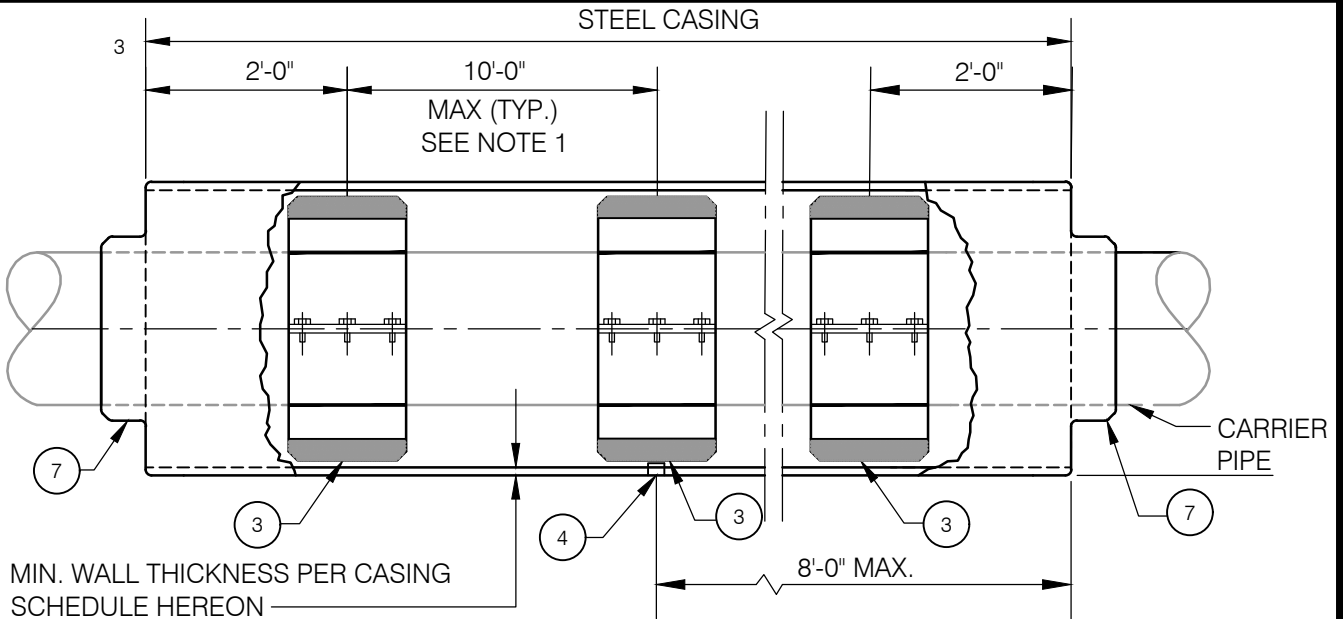

ITEM

MATERIALS

- ① — STEEL CASING
- ② — CARRIER PIPE JOINT BELL, BEYOND.
- ③ — STAINLESS STEEL CASING SPACERS WITH UHMW POLYETHYLENE RUNNERS PER SPEC. SECTION 1.5.11.
- ④ — GROUT FITTING @ 8' O.C. PER DETAIL HEREON. FOR ALL CASINGS 30" IN DIA. AND LARGER, INSTALL ONE COUPLING IN 6 O'CLOCK POSITION @ 8' O.C.; STAGGER COUPLINGS BETWEEN 10 O'CLOCK AND 2 O'CLOCK POSITIONS EVERY 4 LINEAR FEET ALONG CASING AXIS.
- ⑤ — 3" NPT THREADED STEEL PLUG WITH FLUSH HEAD AND INTERNAL TURN HANDLE.
- ⑥ — 2" NPT STANDARD WEIGHT STEEL PIPE HALF COUPLING.
- ⑦ — CASING END SEAL PER SPEC. SECTION 1.5.11 WITH STAINLESS STEEL WORM-SCREW BAND CLAMPS.

NOTE:

1. SPACING TO BE PER MANUFACTURER'S INSTRUCTIONS BUT IN NO CASE GREATER THAN THE MAXIMUM NOTED HERE.

9/1/2022 N:\ECC\WID\EOC\WD-2021-002 Sewer Standards Update\300 Engineering\301 CAD\Plansets\S-08.dwg

			EAST ORANGE COUNTY WATER DISTRICT ORANGE, CALIFORNIA APPROVED BY <i>[Signature]</i> 9/1/2022 GENERAL MANAGER DATE DISTRICT ENGINEER <i>[Signature]</i> 9/1/2022 DATE	<b>PIPE INSTALLATION IN CASING PIPE 1 OF 2</b>	NO SCALE STANDARD DWG. <b>S-8</b>
NO.	APPROVED	DATE			

STEEL CASING SCHEDULE (VCP PIPE) TABLE 1			
VCP SIZE	BELL O.D.	MINIMUM CASING SIZE (NOMINAL)	MINIMUM WALL THICKNESS
6"	11"	18"	5/16"
8"	14"	20"	3/8"
10"	16"	24"	3/8"
12"	19"	27"	3/8"
15"	24"	30"	1/2"
18"	27"	36"	1/2"

STEEL CASING SCHEDULE (PVC PIPE) TABLE 2			
PVC SIZE	BELL O.D.	MINIMUM CASING SIZE (NOMINAL)	MINIMUM WALL THICKNESS
6"	7.1"	16"	5/16"
8"	9.5"	18"	5/16"
10"	11.9"	20"	3/8"
12"	13.9"	24"	3/8"
15"	18.0"	27"	3/8"
18"	21.8"	30"	1/2"

TABLE 3 CASING AND MATERIAL SCHEDULE				
NOMINAL CARRIER PIPE SIZE	CASING MATERIAL		FILL ANNULAR SPACE BETWEEN CASING AND CARRIER PIPE	
	BURIAL DEPTH TO TOP OF CARRIER PIPE			
	10-FEET AND LESS	GREATER THAN 10-FEET	10-FEET AND LESS	GREATER THAN 10-FEET
4"-16"	PVC	STEEL	NO	YES
18"-24"	STEEL	STEEL	NO	YES

**NOTES:**

1. SIZE AND THICKNESS OF CASING SHALL BE AS SHOWN IN TABLE 1 AND TABLE 2.
2. ALL STEEL CASING PIPE FIELD JOINTS SHALL BE WELDED FULL-CIRCUMFERENCE.
3. CARRIER PIPE SHALL BE PRESSURE TESTED PRIOR TO SEALING ENDS OF CASING.
4. EACH END OF CASING SHALL BE SEALED WITH APPROVED RUBBER CASING END SEALS.
5. NUMBER AND PLACEMENT OF SPACERS ON CARRIER PIPE PER MANUFACTURER'S SPECIFICATION.
6. ALL CARRIER PIPE JOINTS INSIDE THE STEEL CASING AND A MIN. 5' OUTSIDE STEEL CASING SHALL BE RESTRAINED.
7. REFER TO TABLE 3 FOR ANNULAR SPACE FILL REQUIREMENTS.

9/1/2022

N:\ECC\DWG\ECOCWD-2021-002 Sewer Standards Update\300 Engineering\301 CAD\Plansets\S-08-2.dwg

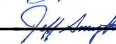
		EAST ORANGE COUNTY WATER DISTRICT ORANGE, CALIFORNIA		PIPE INSTALLATION IN CASING PIPE 2 OF 2		NO SCALE	
		APPROVED BY  9/1/2022				STANDARD DWG.	
		GENERAL MANAGER _____ DATE				S-8	
NO.		APPROVED	DATE	DISTRICT ENGINEER  9/1/2022			

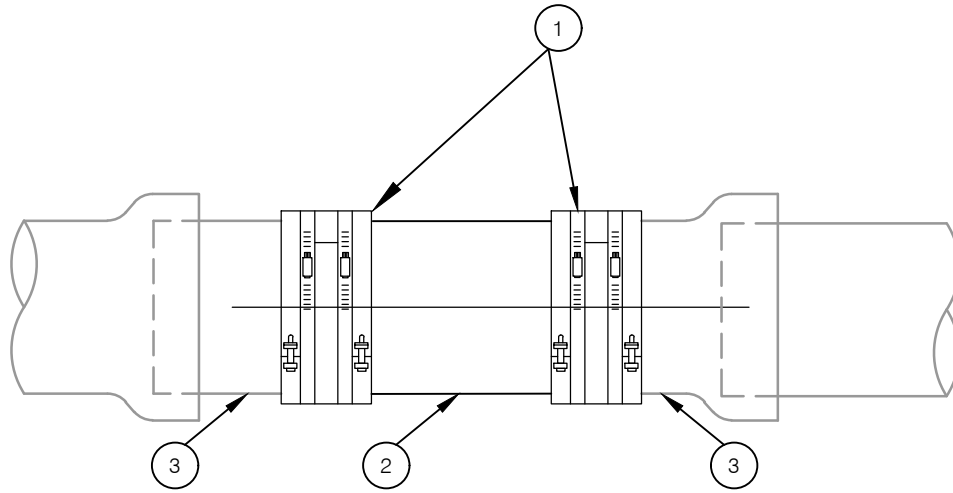

VCP

NOMINAL DIAMETER (INCHES)	MAXIMUM DEFLECTION OF PIPE INCHES/LINEAR FT.
3 TO 12	1/2
15 TO 24	3/8

ITEM                      MATERIALS

- ① — FLEXIBLE BANDED RUBBER COUPLING WITH OUTSIDE TYPE 316 STAINLESS STEEL SHEAR RING.
- ② — NEW VCP PIPE SPOOL
- ③ — EXISTING PIPE

NOTES:

1. FLEXIBLE COUPLING SHALL CONFORM TO ASTM D5926, C1173 AND CSA B602. IT SHALL BE LEAK PROOF AND RESISTANT TO CHEMICALS, ULTRA VIOLET RAYS, FUNGUS GROWTH AND NORMAL SEWER GASES.
2. ALL DEBRIS SHALL BE KEPT OUT OF THE SEWER. THE PIPE REACH CUT-INTO SHALL BE CLEANED AND BALLED, IF NECESSARY, AS DIRECTED BY THE DISTRICT REPRESENTATIVE.

9/1/2022

N:\ECC\WD\ECOCWD-2021-002 Sewer Standards Update\300 Engineering\301 CAD\Plansets\S-09.dwg

NO.	APPROVED	DATE

EAST ORANGE COUNTY WATER DISTRICT  
ORANGE, CALIFORNIA  
APPROVED BY *[Signature]* 9/1/2022  
GENERAL MANAGER DATE  
DISTRICT ENGINEER *[Signature]* 9/1/2022  
DATE

**FIELD CLOSURE FOR VCP  
PIPES**

NO SCALE  
STANDARD DWG.  
**S-9**

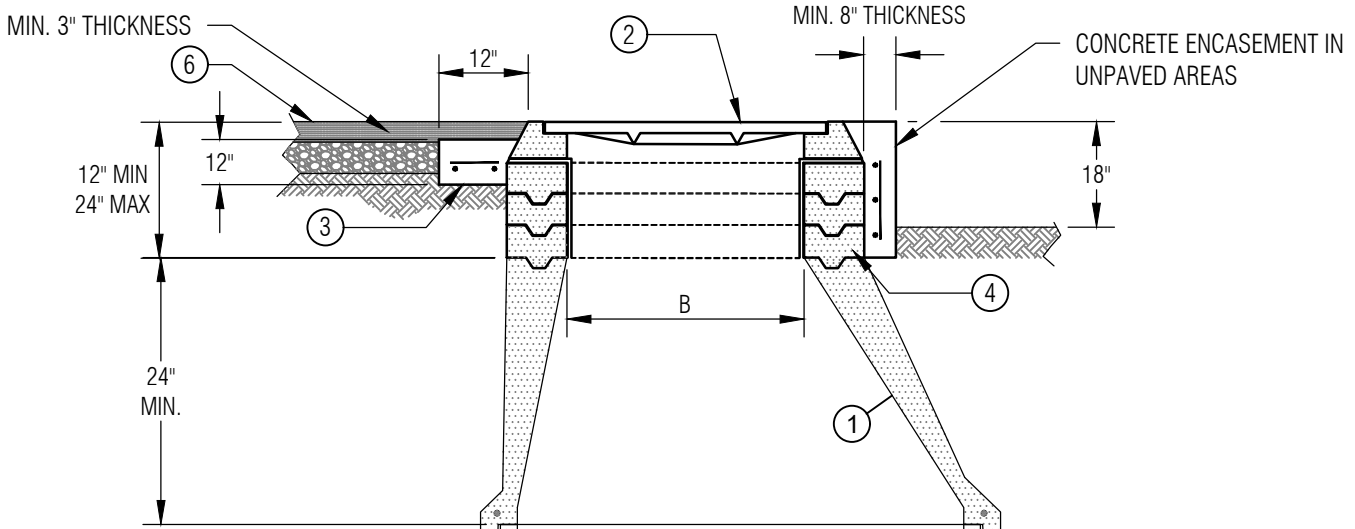

- ① POLYMER CONCRETE GRADE RINGS, CONE, AND BARREL SECTIONS
- ② FRAME AND COVER PER STANDARD DRAWING S-11
- ③ ROUND CLASS "B" CONCRETE COLLAR AND AC PAVEMENT
- ④ SQUARE CLASS "B" CONCRETE PAD WITH 6" x 6" STEEL CENTERED IN CONCRETE
- ⑤ 2" RISER WITH 5" FRP REBAR @ 45° OC, WET SET INTO CONCRETE BASE. (SEE DETAIL B)
- ⑥ CAST-IN-PLACE CONCRETE BASE

SEE DETAIL A ON SHT. 2

SEE DETAIL B ON SHT. 2

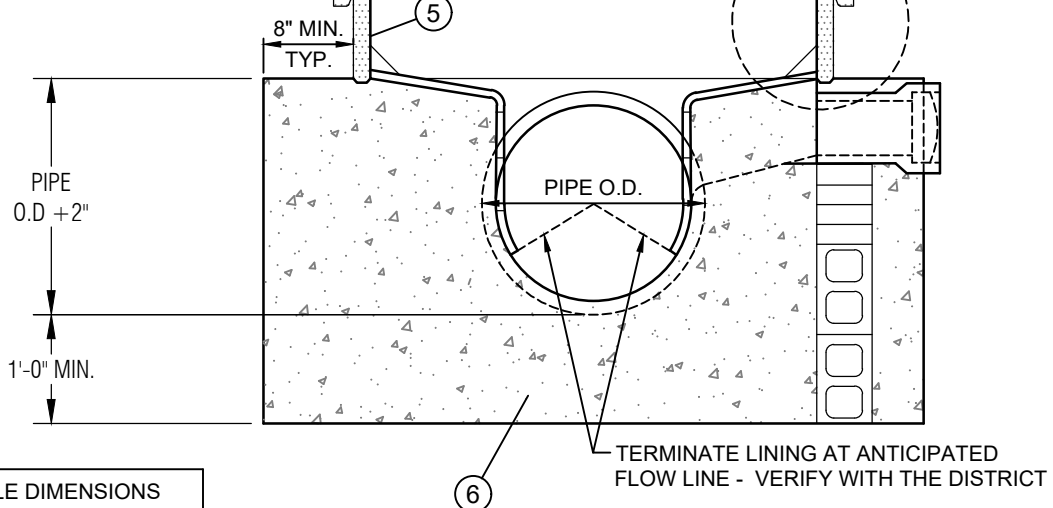

MANHOLE DIMENSIONS		
PIPE SIZE (I.D.)	A	B
8" - 10"	48"	24"
12" - 24"	60"	36"

9/1/2022  
N:\ECCWID\EOCWD-2021-002 Sewer Standards Update\300 Engineering\301 CAD\Plansets\S-10.dwg

EAST ORANGE COUNTY WATER DISTRICT ORANGE, CALIFORNIA		
APPROVED BY	<i>[Signature]</i>	9/1/2022
GENERAL MANAGER		DATE
DISTRICT ENGINEER	<i>[Signature]</i>	9/1/2022
		DATE

**POLYMER CONCRETE  
MANHOLE AND CONCRETE  
BASE 1 OF 2**

NO SCALE  
STANDARD DWG.  
**S-10**

9/1/2022

N:\ECC\WD\ECOC\WD-2021-002 Sewer Standards Update\300 Engineering\301 CAD\Plansets\S-10-2.dwg

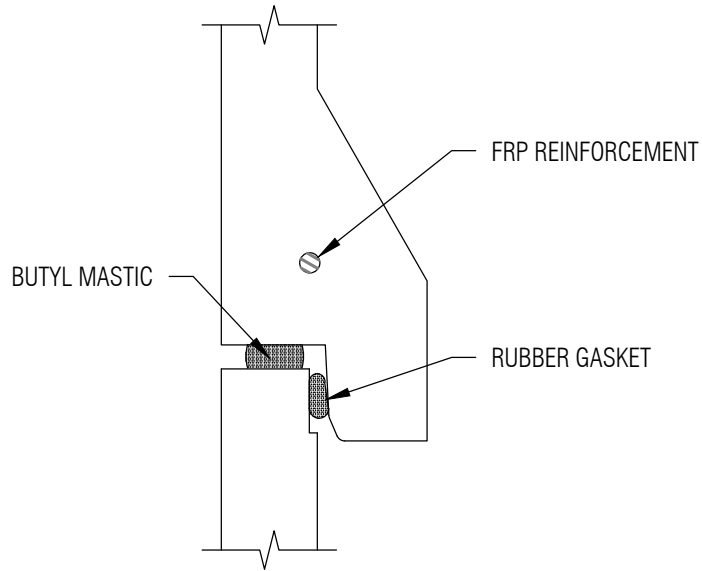

DETAIL A

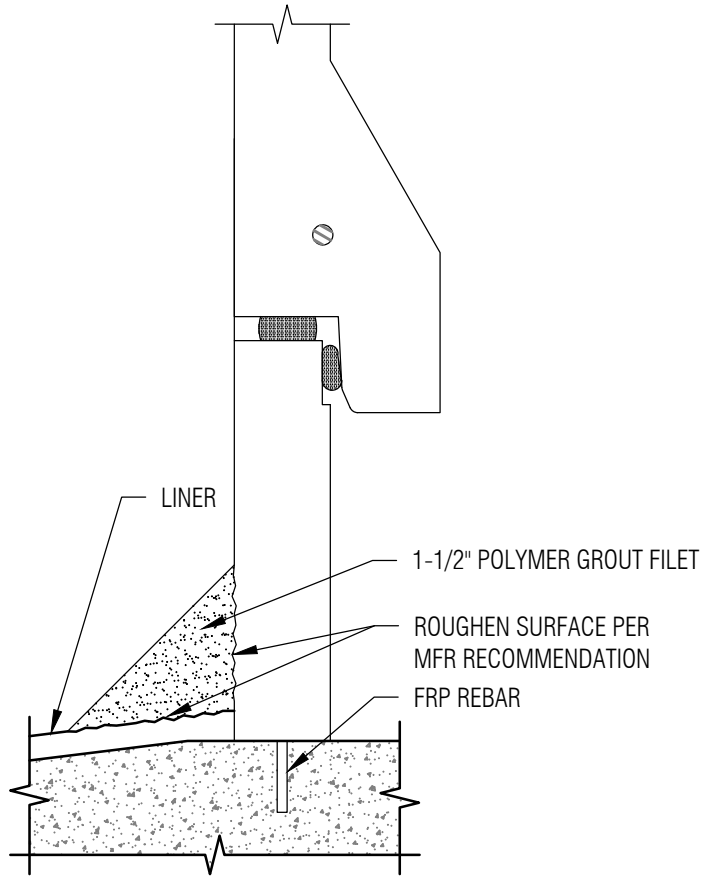

DETAIL B

NOTE:  
 1. REFER TO STANDARD DRAWING S-13 AND S-14 FOR MANHOLE BASE.

NO.	APPROVED	DATE

EAST ORANGE COUNTY WATER DISTRICT  
 ORANGE, CALIFORNIA  
 APPROVED BY *[Signature]* 9/1/2022  
 GENERAL MANAGER DATE  
 DISTRICT ENGINEER *[Signature]* 9/1/2022  
 DISTRICT ENGINEER DATE

**POLYMER CONCRETE  
 MANHOLE AND CONCRETE  
 BASE 2 OF 2**

NO SCALE  
 STANDARD DWG.  
**S-10**

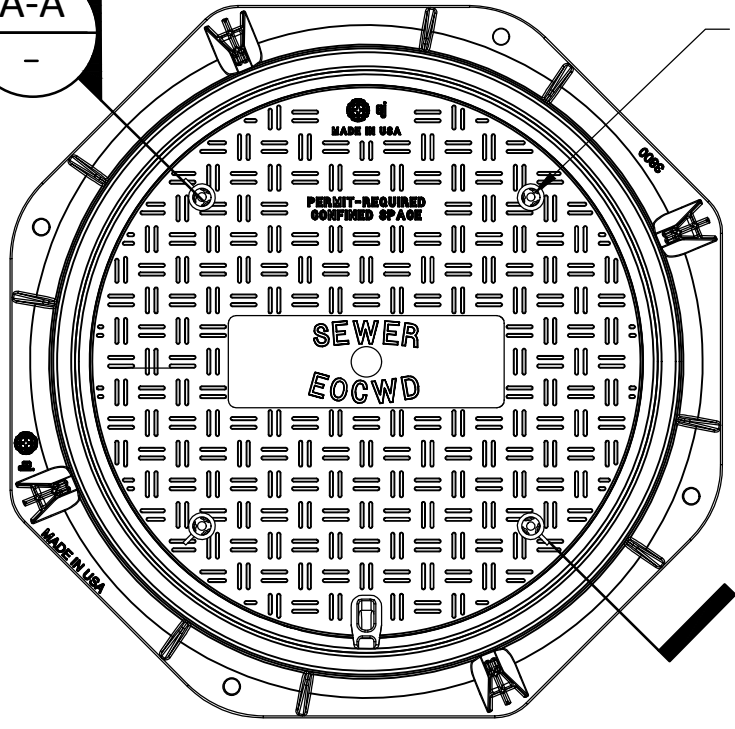
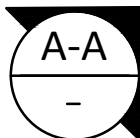

1/4"-TURN EOCWD-SPECIFIC  
TWISTLIFT LOCK (4 LOCATIONS)

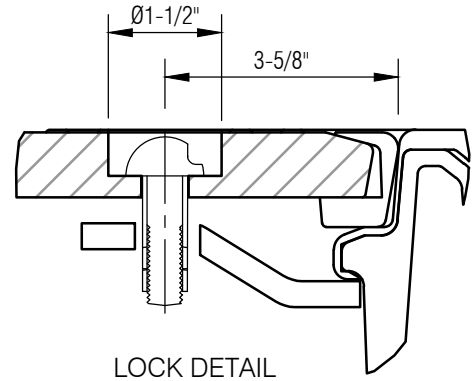

LOCK DETAIL

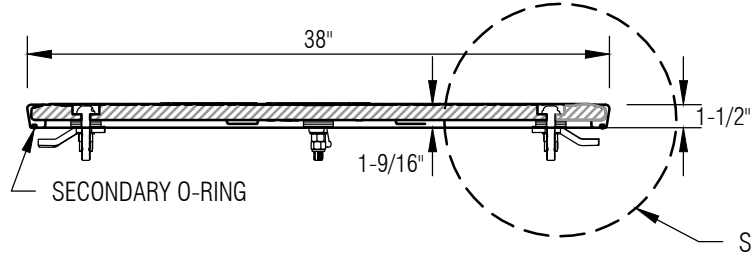

SECONDARY O-RING

SEE LOCK DETAIL

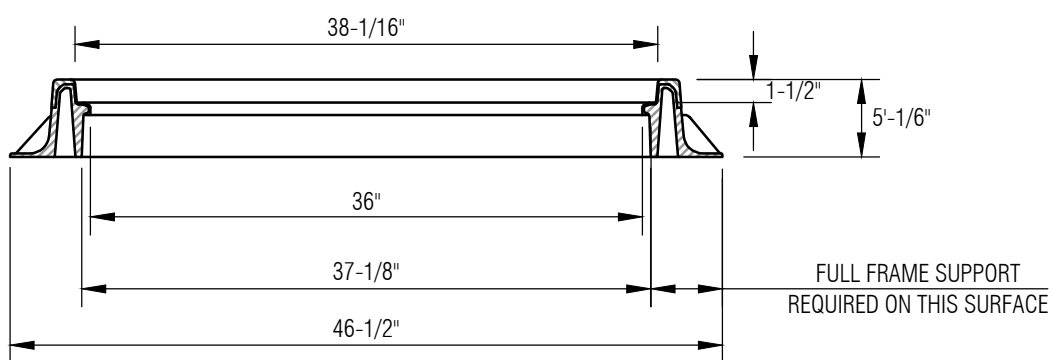

FULL FRAME SUPPORT  
REQUIRED ON THIS SURFACE

SECTION A-A

NOTE: COMPOSITE MANHOLE COVER SHOULD NOT BE USED ON ARTERIAL STREETS.

9/1/2022

N:\EOCWD\EOCWD-2021-002 Sewer Standards Update\300 Engineering\301 CAD\Plansets\S-11-1.dwg

NO.	APPROVED	DATE

EAST ORANGE COUNTY WATER DISTRICT  
ORANGE, CALIFORNIA  
APPROVED BY *[Signature]* 9/1/2022  
GENERAL MANAGER DATE  
DISTRICT ENGINEER *[Signature]* 9/1/2022  
DATE

COMPOSITE MANHOLE  
FRAME AND COVER  
(36" CLEAR OPENING) 1 OF 2

NO SCALE  
STANDARD DWG.  
**S-11**

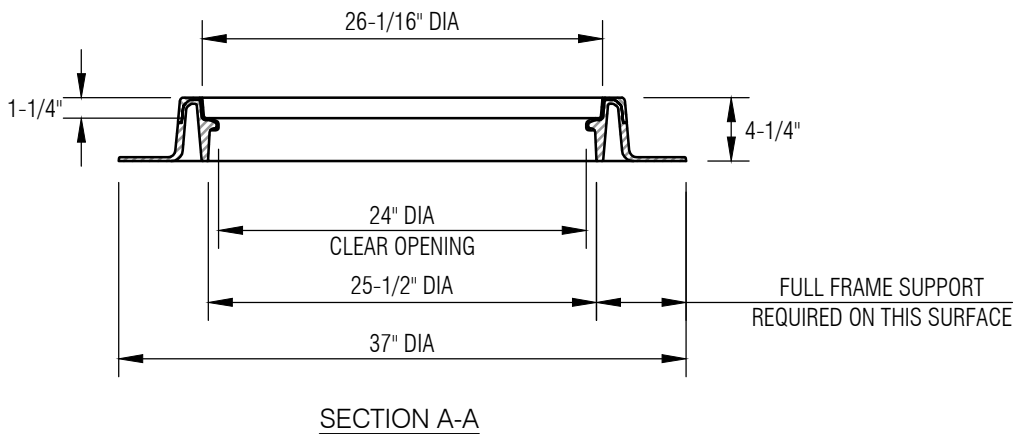
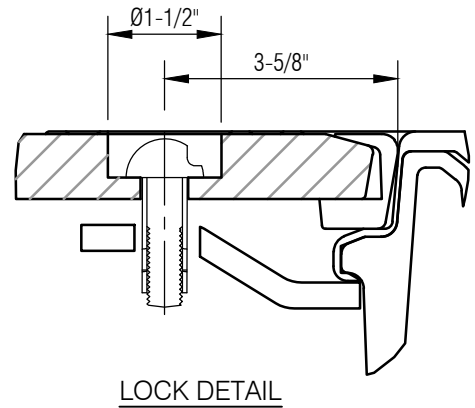
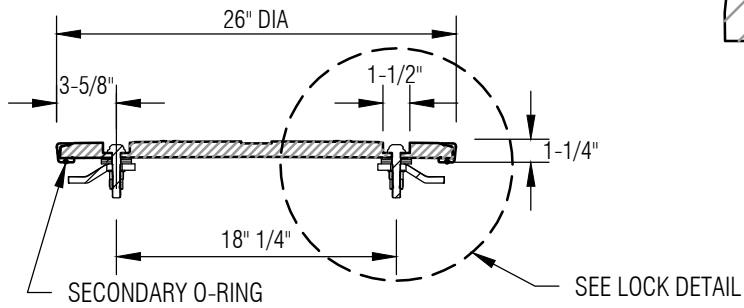
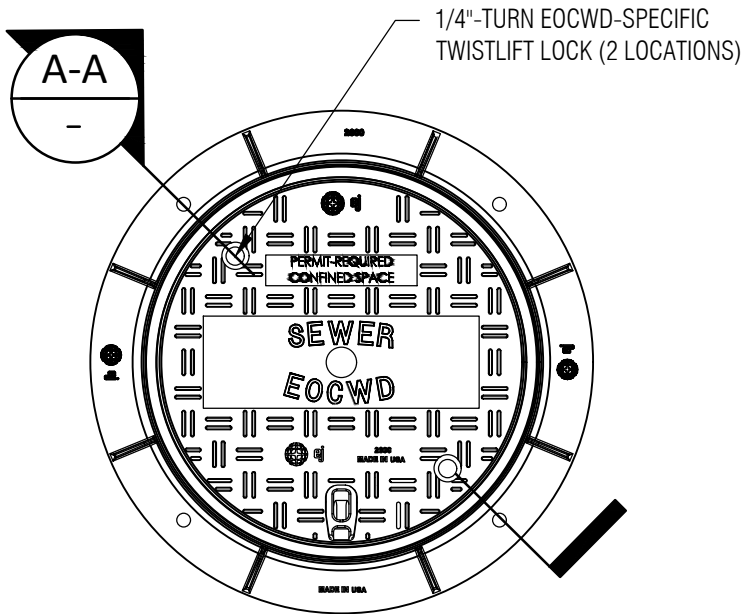

NOTE: COMPOSITE MANHOLE COVER SHOULD NOT BE USED ON ARTERIAL STREETS.

9/1/2022

N:\EOCWD\EOCWD-2021-002 Sewer Standards Update\300 Engineering\301 CAD\Plansets\S-11-2.dwg

NO.	APPROVED	DATE

EAST ORANGE COUNTY WATER DISTRICT ORANGE, CALIFORNIA	
APPROVED BY	9/1/2022
GENERAL MANAGER	DATE
DISTRICT ENGINEER	DATE

**COMPOSITE MANHOLE  
FRAME AND COVER  
(24" CLEAR OPENING) 2 OF 2**

NO SCALE  
STANDARD DWG.  
**S-11**

9/1/2022

N:\ECC\DWG\ECC\2021-002 Sewer Standards Update\300 Engineering\301 CAD\Plansets\S-12.dwg

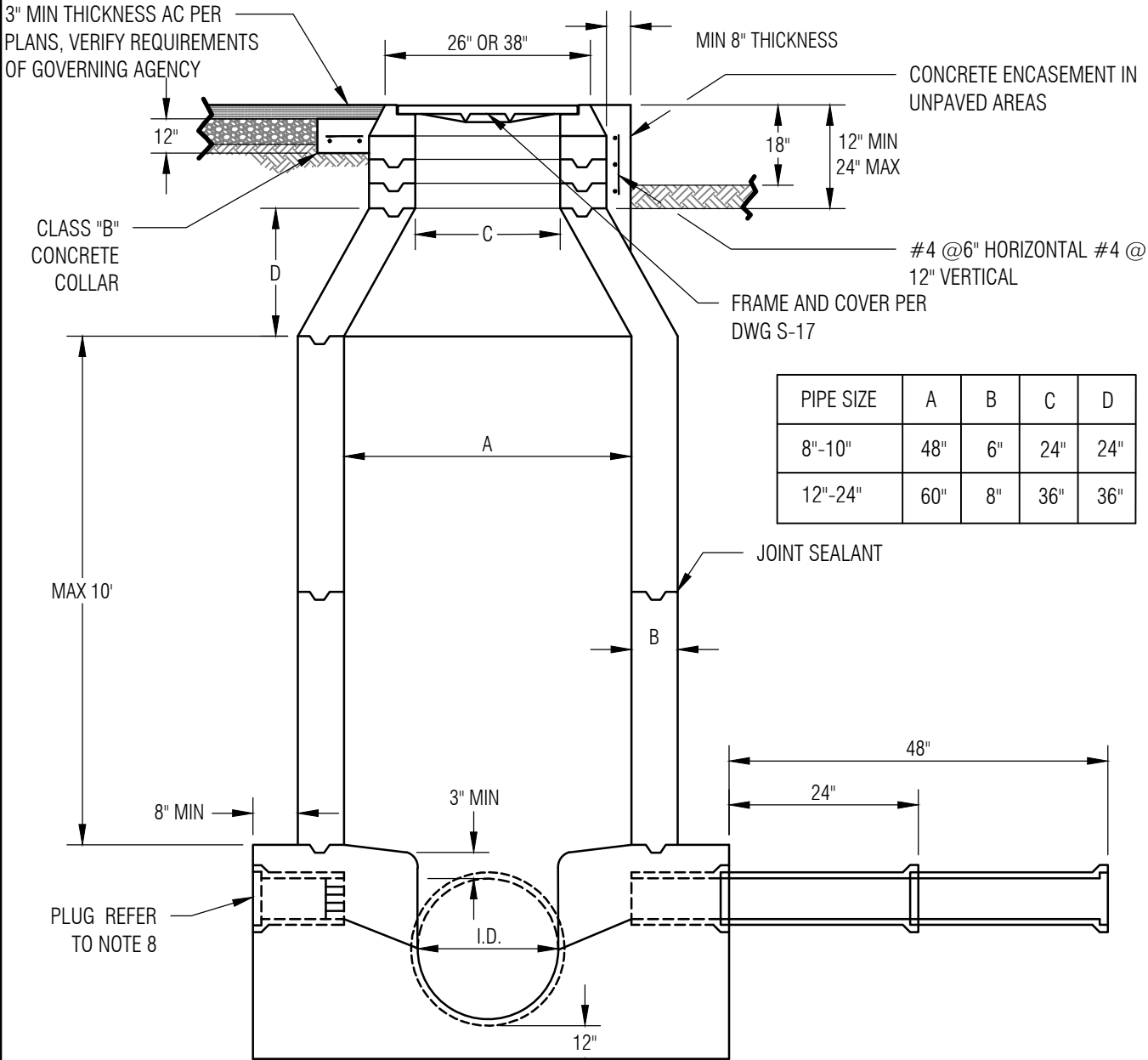

**NOTES:**

1. NO STEPS ARE ALLOWED IN ANY MANHOLE. ALL SHAFTS AND CONES SHALL BE PRECAST. ECCENTRIC CONE SHALL BE SET WITH STRAIGHT SIDE ON THE DOWNSTREAM SIDE OF THE MANHOLE. SHAFT AND CONE MAY BE REINFORCED OR NON-REINFORCED.
2. MANHOLE BASE SHALL BE POURED WITH CLASS "A" CONCRETE.
3. SIDES OF BASE SHALL BE EITHER FORMED OR POURED AGAINST VERTICAL SMOOTH EARTH.
4. CROWN OF LATERAL SHALL MATCH CROWN OF MAIN.
5. MANHOLE PLACED IN UNPAVED AREAS MAY BE REQUIRED TO HAVE THEIR FRAMES AND COVERS SET 18" AND COVERS SET 18" ABOVE FINISHED GRADE. (RAISED MANHOLES SHOULD ONLY BE USED IN SPECIFIC CIRCUMSTANCES AS APPROVED BY THE DISTRICT)
6. WHEN THE DEPTH OF MANHOLE EXCEEDS 15' FROM THE TOP OF PIPE TO FINISHED GRADE THE MANHOLE SHAFT SHALL BE INCREASED TO A DIAMETER OF 60" WITH 36" DIAMETER COVER AND MANHOLE BASE SHALL BE REINFORCED, REFER TO STD DRAWING S-13 FOR MANHOLE BASE.
7. BACKFILL WITH ONE-SACK SLURRY.
8. FOR VCP AND PVC LATERAL PLUG REFER TO STD DRAWING S-13.

			EAST ORANGE COUNTY WATER DISTRICT ORANGE, CALIFORNIA APPROVED BY <i>[Signature]</i> 9/1/2022 GENERAL MANAGER DATE DISTRICT ENGINEER <i>[Signature]</i> 9/1/2022 DATE	NO SCALE STANDARD DWG. <b>S-12</b>
NO.	APPROVED	DATE	<b>NEW UN-LINED MANHOLE FOR SEWERS</b>	

9/1/2022

N:\ECC\DWG\2021-002 Sewer Standards Update\300 Engineering\301 CAD\Plansets\S-13\_1 - 1 OF 3.dwg

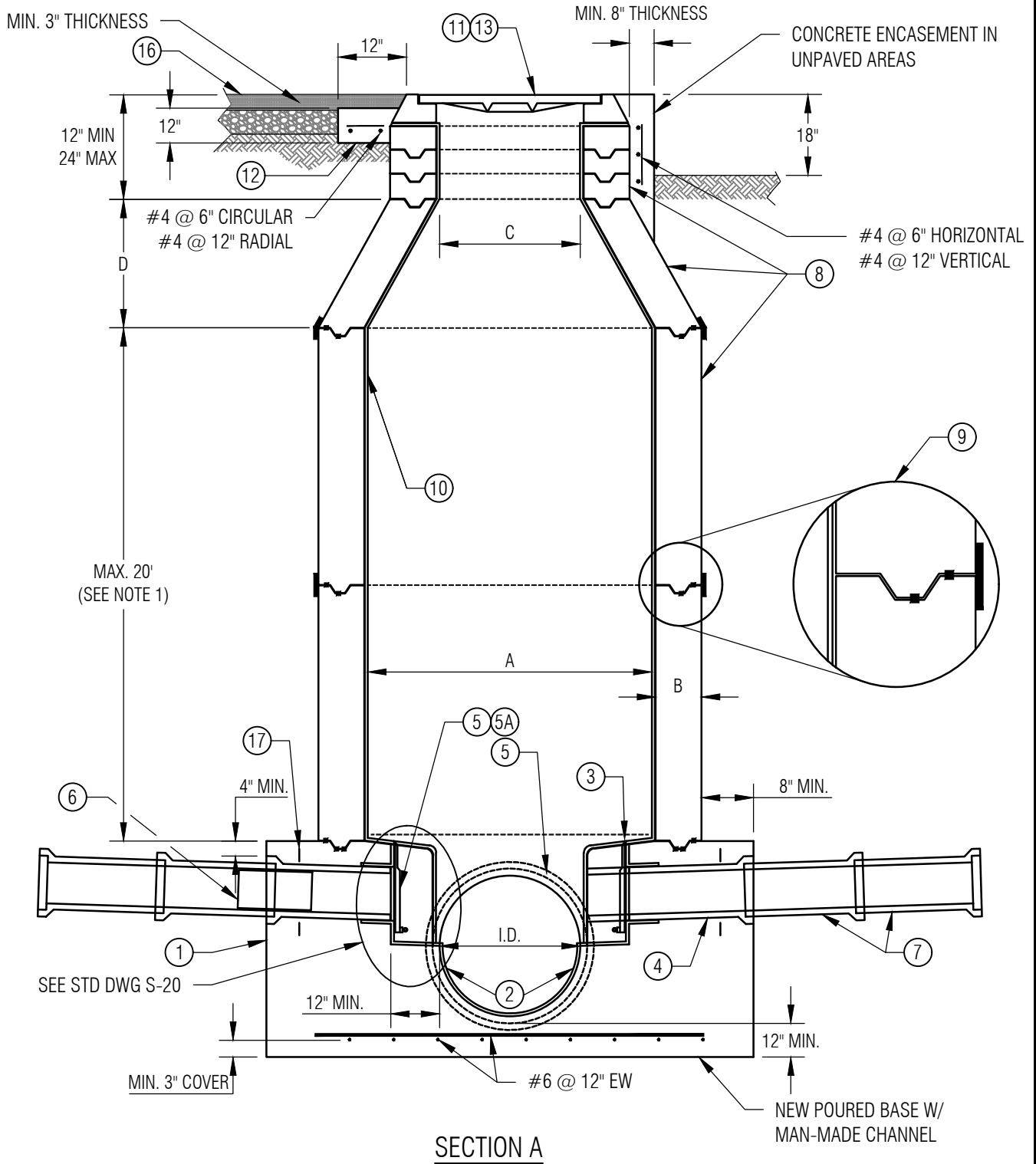

**NOTE:**

1. MANHOLE DEPTH GREATER THAN 20', DIMENSION 'A' PER PLANS.
2. MANHOLE BEDDING SHALL BE MIN. 12" ROCK BEDDING OR APPROVED EQUAL.

PIPE SIZE (I.D.)	A	B	C	D
8" - 10"	40"	6"	24"	24"
12" - 24"	60"	8"	36"	36"

NO.	APPROVED	DATE

EAST ORANGE COUNTY WATER DISTRICT  
ORANGE, CALIFORNIA

APPROVED BY *[Signature]* 9/1/2022  
DATE

GENERAL MANAGER *[Signature]* 9/1/2022  
DATE

DISTRICT ENGINEER *[Signature]* 9/1/2022  
DATE

**NEW LINED MANHOLE OVER  
EXISTING SEWER 1 OF 3**

NO SCALE  
STANDARD DWG.  
**S-13**

9/1/2022

N:\ECC\DWG\2021-002 Sewer Standards Update\300 Engineering\301 CAD\Plansets\S-13\_2 - 2 OF 3.dwg

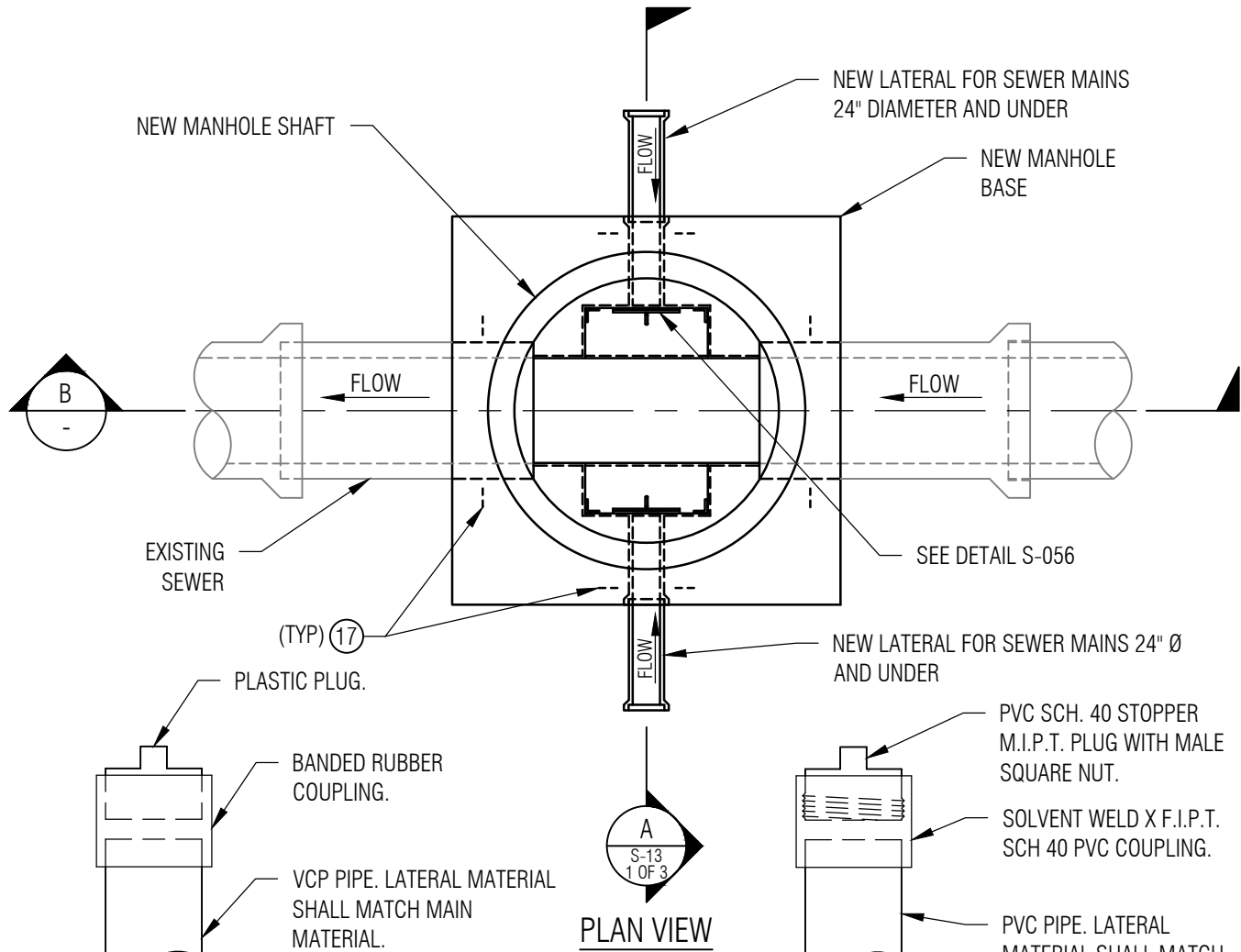

**A**  
S-13  
1 OF 3

**PLAN VIEW**

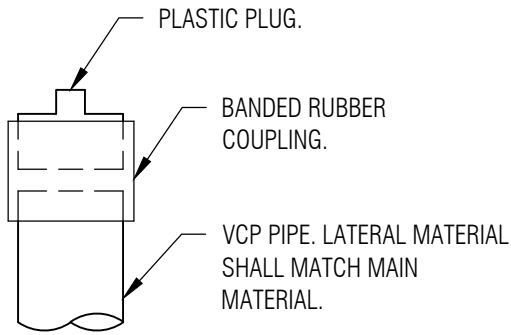

**VCP STOPPER DETAIL**  
DETAIL 2

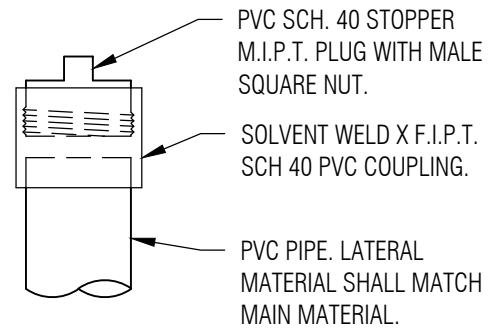

**PVC STOPPER DETAIL**  
DETAIL 3

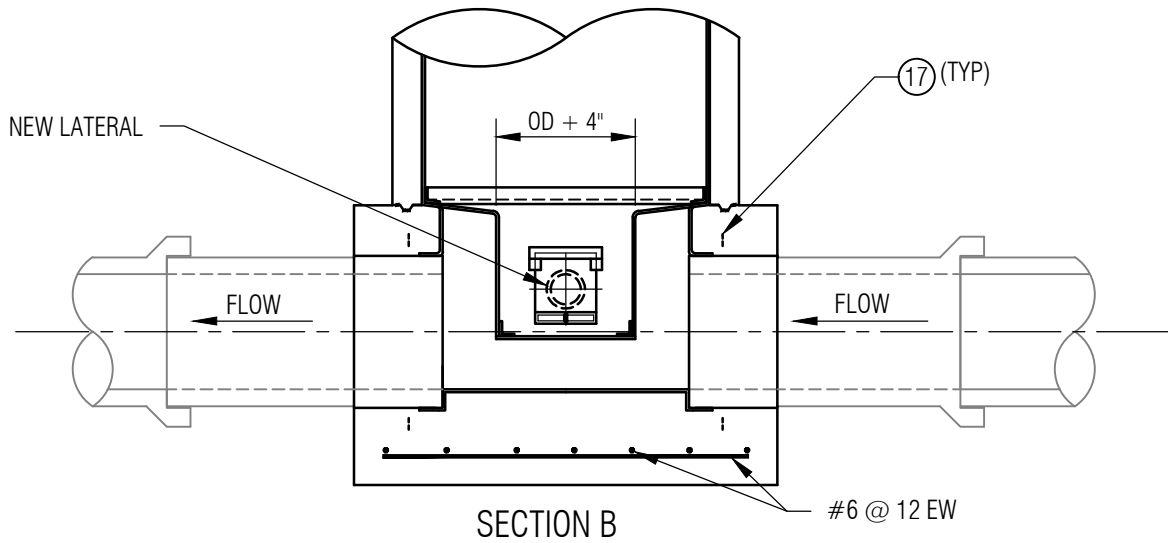

**SECTION B**

NO.	APPROVED	DATE

EAST ORANGE COUNTY WATER DISTRICT  
ORANGE, CALIFORNIA

APPROVED BY *[Signature]* 9/1/2022  
DATE

GENERAL MANAGER *[Signature]* 9/1/2022  
DATE

DISTRICT ENGINEER *[Signature]* 9/1/2022  
DATE

**NEW LINED MANHOLE OVER  
EXISTING SEWER 2 OF 3**

NO SCALE  
STANDARD DWG.  
**S-13**

NOTES:

- ① MANHOLES SHALL HAVE 4000 # (CLASS "A"), CONCRETE BASES WITH #6 (19 MM) BARS @ 12" E.W. SIDES OF BASE SHALL BE FORMED BY EITHER WOOD FORMS OR SANDBAGS. BASE MAY BE EITHER CIRCULAR OR RECTANGULAR. IF CIRCULAR, THE AREA SHALL BE EQUAL TO THE AREA OF THE SQUARE BASE. ALL CONCRETE AND MORTAR SHALL USE CLASS II/V CEMENT.
- ② THE BASE'S CHANNEL SHALL BE CONSTRUCTED WITH FORMS AND LINED. WHERE PVC LINED RCP IS USED, THE EXISTING PIPE SHALL BE REMOVED BY SAW CUTTING. THE REMOVED SECTION SHALL BE OF A LENGTH THAT THE ENDS OF THE REMAINING PIPE AT ITS SPRINGLINE IS FLUSH WITH THE MANHOLE'S SHAFT INSIDE DIAMETER.
- ③ MANHOLE SHELVES SHALL BE SLOPED 1/4" PER FOOT TO CHANNEL AND COVERED WITH LINER WITH LOCKING EXTENSIONS. INSTALL NON-SKID SURFACE ON PVC LINER OVER THE COMPLETE MANHOLE SHELF ON BOTH SIDES OF MAIN CHANNEL PER THE SPECIFICATION OR APPROVED LINER MANUFACTURER RECOMMENDATIONS. A PVC ANGLE STRIP SHALL BE USED FOR THE TRANSITION BETWEEN HORIZONTAL SHELF AND VERTICAL CHANNEL.
- ④ INSTALL AT LEAST TWO LATERAL INLET PIPES IN THE MANHOLE BASE AS SHOWN. IF NOT SHOWN, LATERAL PIPING SHALL BE 8" AT 90° TO THE MAIN CHANNEL AND SLOPED AT 1/4" PER FOOT FROM THE OUTSIDE OF THE MANHOLE BASE TO THE CHANNEL WHERE THE CHANNEL ANGLES MORE THAN 45° TOWARD A SIDE, THAT SIDE LATERAL IS NOT REQUIRED.
- ⑤ THE SOFFIT OF ALL LATERAL PIPES SHALL BE AT THE SAME ELEVATION AS THE MAIN PIPE SOFFIT. ALL LATERAL INLETS 12" DIAMETER AND SMALLER SHALL HAVE GAS FLAPS INSTALLED SIMILAR TO DRAWING S-20, UNLESS OTHERWISE NOTED BY THE ENGINEER. PVC LINER SHALL BE PLACED THROUGHOUT THE CHANNEL AND PVC TURN BACK ON VCP OR OTHER PIPE SHALL BE A MINIMUM OF 6".
- ⑤A FOR MANHOLE BASES WHERE MAIN SEWER PIPE IS LESS THAN 24" IN DIAMETER, THE LATERALS SHALL BE RECESSED 12" MINIMUM FROM MAIN LINE CHANNEL WITH A TROUGH IN THE BENCH SLOPING TO THE MAIN CHANNEL.
- ⑥ ALL UNUSED CONNECTIONS SHALL HAVE A FACTORY MADE VCP OR PVC PLUG (DETAILS 2 AND 3 ON SHEET 2) INSTALLED IN THE BELL END OF THE PIPE WITH RESTRAINT SUFFICIENT TO WITHSTAND LEAKAGE TESTING. PIPE OVER 21" SHALL USE A BRICK AND MORTAR PLUG.
- ⑦ EACH MAIN LINE OR LATERAL CONNECTION TO THE MANHOLE BASE SHALL HAVE TWO EACH, TWO FOOT JOINTS.
- ⑧ MANHOLE SECTIONS AND GRADE RINGS SHALL BE REINFORCED, MADE FROM CLASS II/V CEMENT AND CAST WITH PVC LINER PLATE ON INSIDE. ECCENTRIC CONE SHALL BE SET WITH STRAIGHT SIDE ON DOWNSTREAM SIDE OF MANHOLE. ECCENTRIC REINFORCED CONCRETE FLAT TOPS MAY BE USED WHEN APPROVED BY THE ENGINEER.
- ⑨ THE KEYLOCK JOINT BETWEEN MANHOLE SECTIONS SHALL BE SEALED WITH TWO 1-1/4" SQUARE BEADS OF RAM-NEK BY HENRY COMPANY, KENT-SEAL No. 2 BUTYL SEALANT BY HAMILTON KENT, OR APPROVED EQUAL. THE MASTIC BEADS SHALL BE PLACED ON THE OUTSIDE SHOULDER OF AND IN THE GROOVE. APPLY A 6" MINIMUM WIDTH OUTSIDE JOINT WRAP, RUB'R-NEK BY HENRY COMPANY, INFI-SHIELD OR GATOR RAP BY SEALING SYSTEMS, INC., OR EQUAL, TO ALL SHAFT JOINTS. GRADE RING JOINTS SHALL BE MORTAR.
- ⑩ LINER SEE SPEC SECTION 1.5.5.
- ⑪ INSTALL FRAME AND COVER PER STANDARD DRAWING S-16,S-17,OR S-18. ADJUSTMENT SHALL OCCUR USING MORTAR BETWEEN FIRST AND SECOND GRADE RINGS. THE FRAME SHALL COMPLETELY BEAR ON PVC. CAULK THE JOINT BETWEEN THE FRAME AND THE PREFORMED PVC CORNER AT THE TOP GRADE RING WITH SIKAFLEX 1A OR EQUAL.
- ⑫ PLACE CONCRETE COLLAR IN PAVED AREAS AS SHOWN AFTER PLACEMENT OF ASPHALT. SEE DRAWING S-19. MANHOLES PLACED IN UNPAVED AREAS SHALL HAVE THE COVERS PLACED 18" ABOVE FINISHED GRADE. (RAISED MANHOLES SHOULD BE USED IN SPECIFIC CIRCUMSTANCES AS APPROVED BY THE DISTRICT) EXPOSED CONCRETE SHALL BE FINISHED AND COATED SAFETY YELLOW.
- ⑬ MANHOLES IN INTERSECTIONS SHALL HAVE BOLTED COVERS.
- ⑭ VACUUM TESTING SHALL BE PERFORMED PER ASTM C-1244 UNLESS NOTED OTHERWISE.
- ⑮ MANHOLES SHALL BE BACKFILLED WITH 1-1/2 SACK SAND/CEMENT SLURRY TO STREET ZONE OR AS REQUIRED BY LOCAL AGENCY.
- ⑯ IN PAVED AREAS, PAVEMENT AND BASE COURSE SHALL BE REPLACED IN KIND, UNLESS OTHERWISE NOTED BY THE GOVERNING AGENCY.
- ⑰ INSTALL A WEEP RING AT VCP/HDPE PENETRATIONS WITH HIGH GROUND WATER CONDITIONS.

9/1/2022

N:\ECCWD\ECOWD-2021-002 Sewer Standards Update\300 Engineering\301 CAD\Plansets\S-13\_3 -3 OF 3.dwg

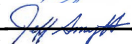
		EAST ORANGE COUNTY WATER DISTRICT ORANGE, CALIFORNIA		NEW LINED MANHOLE OVER EXISTING SEWER 3 OF 3		NO SCALE	
		APPROVED BY  9/1/2022				STANDARD DWG.	
		GENERAL MANAGER _____ DATE				S-13	
NO.	APPROVED	DATE	DISTRICT ENGINEER  9/1/2022				
			DATE				



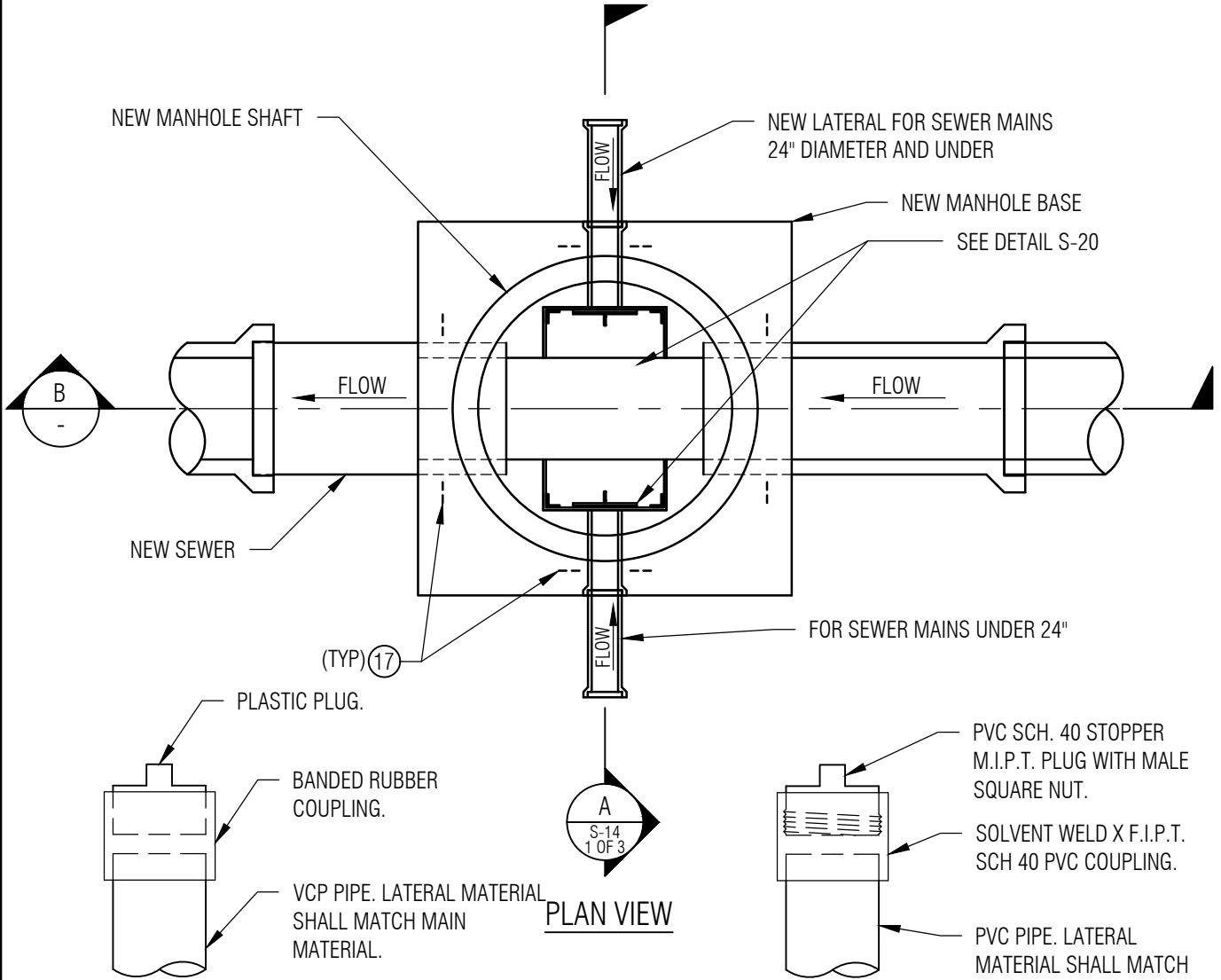

PLAN VIEW  
 A  
 S-14  
 1 OF 3

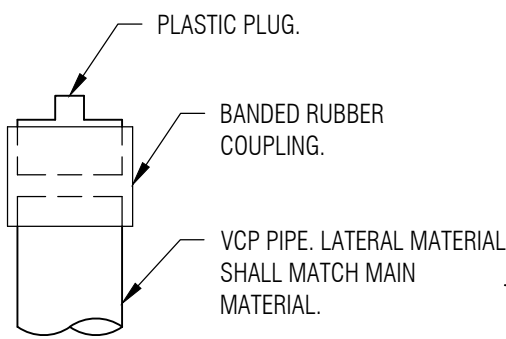

VCP STOPPER DETAIL  
 DETAIL 2

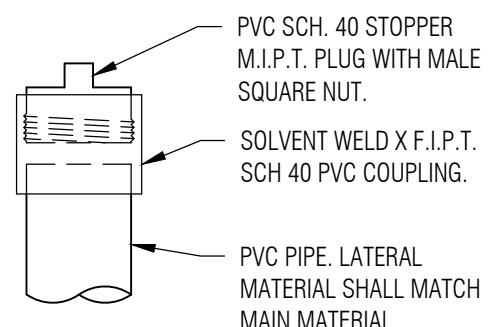

PVC STOPPER DETAIL  
 DETAIL 3

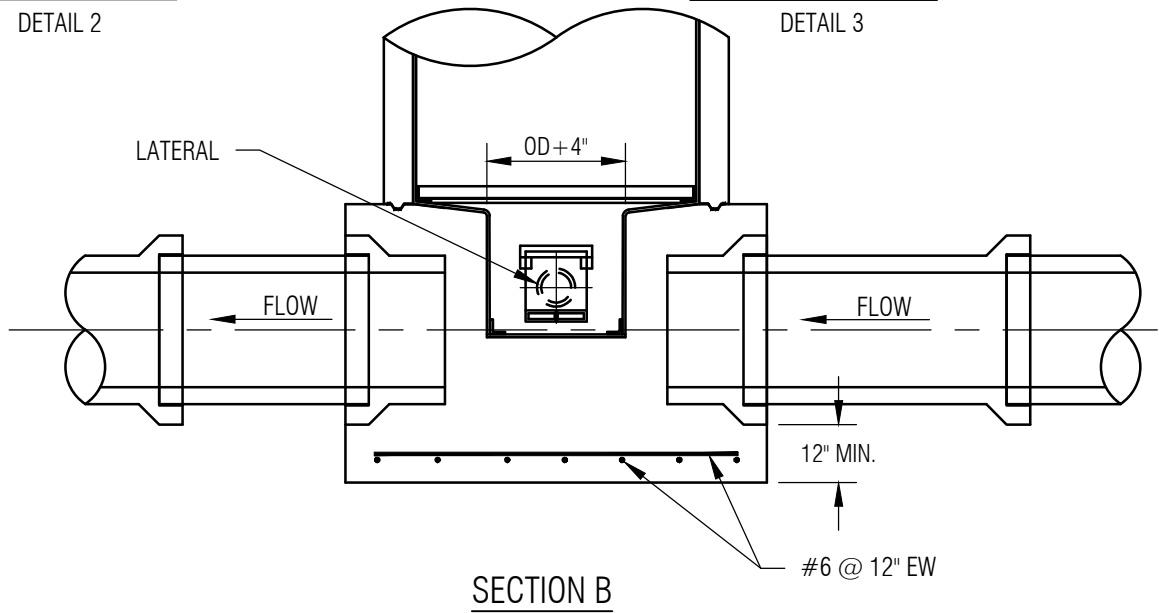

SECTION B

9/1/2022  
 N:\ECC\WID\ECOWD-2021-002 Sewer Standards Update\300 Engineering\301 CAD\Plansets\S-14\_2 - 2 OF 3.dwg

NO.	APPROVED	DATE

EAST ORANGE COUNTY WATER DISTRICT  
 ORANGE, CALIFORNIA

APPROVED BY *[Signature]* 9/1/2022  
 GENERAL MANAGER DATE

DISTRICT ENGINEER *[Signature]* 9/1/2022  
 DATE

NEW LINED MANHOLE FOR  
 NEW SEWERS 2 OF 3

NO SCALE  
 STANDARD DWG.  
**S-14**

NOTES:

- ① MANHOLES SHALL HAVE 4000 # (CLASS "A"), CONCRETE BASES WITH #6 (19 MM) BARS @ 12" E.W. SIDES OF BASE SHALL BE FORMED BY EITHER WOOD FORMS OR SANDBAGS. BASE MAY BE EITHER CIRCULAR OR RECTANGULAR. IF CIRCULAR, THE AREA SHALL BE EQUAL TO THE AREA OF THE SQUARE BASE. ALL CONCRETE AND MORTAR SHALL USE CLASS II/V CEMENT.
- ② THE BASE'S CHANNEL SHALL BE CONSTRUCTED WITH FORMS AND LINED.
- ③ MANHOLE SHELVES SHALL BE SLOPED 1/4" PER FOOT TO CHANNEL AND COVERED WITH PVC LINER WITH LOCKING EXTENSIONS. INSTALL NON-SKID SURFACE ON PVC LINER OVER THE COMPLETE MANHOLE SHELF ON BOTH SIDES OF MAIN CHANNEL PER THE SPECIFICATION OR APPROVED LINER MANUFACTURER RECOMMENDATIONS. A PVC ANGLE STRIP SHALL BE USED FOR THE TRANSITION BETWEEN HORIZONTAL SHELF AND VERTICAL CHANNEL.
- ④ INSTALL AT LEAST TWO LATERAL INLET PIPES IN THE MANHOLE BASE AS SHOWN. IF NOT SHOWN, LATERAL PIPING SHALL BE 8" AT 90° TO THE MAIN CHANNEL AND SLOPED AT 1/4" PER FOOT FROM THE OUTSIDE OF THE MANHOLE BASE TO THE CHANNEL WHERE THE CHANNEL ANGLES MORE THAN 45° TOWARD A SIDE, THAT SIDE LATERAL IS NOT REQUIRED.
- ⑤ THE SOFFIT OF ALL LATERAL PIPES SHALL BE AT THE SAME ELEVATION AS THE MAIN PIPE SOFFIT. ALL LATERAL INLETS 12" DIAMETER AND SMALLER SHALL HAVE GAS FLAPS INSTALLED SIMILAR TO DRAWING S-20, UNLESS OTHERWISE NOTED BY THE ENGINEER. PVC LINER SHALL BE PLACED THROUGHOUT THE CHANNEL AND PVC TURN BACK ON VCP OR OTHER PIPE SHALL BE A MINIMUM OF 6".
- ⑤A FOR MANHOLE BASES WHERE MAIN SEWER PIPE IS LESS THAN 24" IN DIAMETER, THE LATERALS SHALL BE RECESSED 12" MINIMUM FROM MAIN LINE CHANNEL WITH A TROUGH IN THE BENCH SLOPING TO THE MAIN CHANNEL.
- ⑥ ALL UNUSED CONNECTIONS SHALL HAVE A FACTORY MADE VCP OR PVC (DETAILS 2 AND 3 ON SHEET 2) PLUG INSTALLED IN THE BELL END OF THE PIPE WITH RESTRAINT SUFFICIENT TO WITHSTAND LEAKAGE TESTING. PIPE OVER 21" SHALL USE A BRICK AND MORTAR PLUG.
- ⑦ EACH MAIN LINE OR LATERAL CONNECTION TO THE MANHOLE BASE SHALL HAVE TWO EACH, TWO FOOT JOINTS.
- ⑧ MANHOLE SECTIONS AND GRADE RINGS SHALL BE REINFORCED, MADE FROM CLASS II/V CEMENT AND CAST WITH PVC LINER PLATE ON INSIDE. ECCENTRIC CONE SHALL BE SET WITH STRAIGHT SIDE ON DOWNSTREAM SIDE OF MANHOLE. ECCENTRIC REINFORCED CONCRETE FLAT TOPS MAY BE USED WHEN APPROVED BY THE ENGINEER.
- ⑨ THE KEYLOCK JOINT BETWEEN MANHOLE SECTIONS SHALL BE SEALED WITH TWO 1-1/4" SQUARE BEADS OF RAM-NEK BY HENRY COMPANY, KENT-SEAL NO. 2 BUTYL SEALANT BY HAMILTON KENT, OR APPROVED EQUAL. THE MASTIC BEADS SHALL BE PLACED ON THE OUTSIDE SHOULDER OF AND IN THE GROOVE. APPLY A 6" MINIMUM WIDTH OUTSIDE JOINT WRAP, RUB'R-NEK BY HENRY COMPANY, INFI-SHIELD OR GATOR RAP BY SEALING SYSTEMS, INC., OR EQUAL, TO ALL SHAFT JOINTS. GRADE RING JOINTS SHALL BE MORTAR.
- ⑩ LINER SEE SPEC SECTION 1.5.5.
- ⑪ INSTALL FRAME AND COVER PER STANDARD DRAWING S-16,S-17,OR S-18 . ADJUSTMENT SHALL OCCUR USING MORTAR BETWEEN FIRST AND SECOND GRADE RINGS. THE FRAME SHALL COMPLETELY BEAR ON PVC. CAULK THE JOINT BETWEEN THE FRAME AND THE PREFORMED PVC CORNER AT THE TOP GRADE RING WITH SIKAFLEX 1A OR EQUAL.
- ⑫ PLACE CONCRETE COLLAR IN PAVED AREAS AS SHOWN AFTER PLACEMENT OF ASPHALT. SEE DRAWING S-19. MANHOLES PLACED IN UNPAVED AREAS SHALL HAVE THE COVERS PLACED 18" ABOVE FINISHED GRADE. (RAISED MANHOLES SHOULD BE USED IN SPECIFIC CIRCUMSTANCES AS APPROVED BY THE DISTRICT)EXPOSED CONCRETE SHALL BE FINISHED AND COATED SAFETY YELLOW.
- ⑬ MANHOLES IN INTERSECTIONS SHALL HAVE BOLTED COVERS.
- ⑭ VACUUM TESTING SHALL BE PERFORMED PER ASTM C-1244 UNLESS NOTED OTHERWISE.
- ⑮ MANHOLES SHALL BE BACKFILLED WITH 1-1/2 SACK SAND/CEMENT SLURRY TO STREET ZONE OR AS REQUIRED BY LOCAL AGENCY.
- ⑯ IN PAVED AREAS, PAVEMENT AND BASE COURSE SHALL BE REPLACED IN KIND, UNLESS OTHERWISE NOTED BY THE GOVERNING AGENCY.
- ⑰ INSTALL A WEEP RING AT VCP/HDPE PENETRATIONS WITH HIGH GROUND WATER CONDITIONS.

9/1/2022

N:\ECCWID\ECOWD-2021-002 Sewer Standards Update\300 Engineering\301 CAD\Plansets\S-14\_3 - 3 OF 3.dwg

			EAST ORANGE COUNTY WATER DISTRICT ORANGE, CALIFORNIA		NO SCALE	
			APPROVED BY	9/1/2022		
			GENERAL MANAGER	DATE	STANDARD DWG. <b>S-14</b>	
NO.	APPROVED	DATE	DISTRICT ENGINEER	DATE		

**NEW LINED MANHOLE FOR  
NEW SEWERS 3 OF 3**

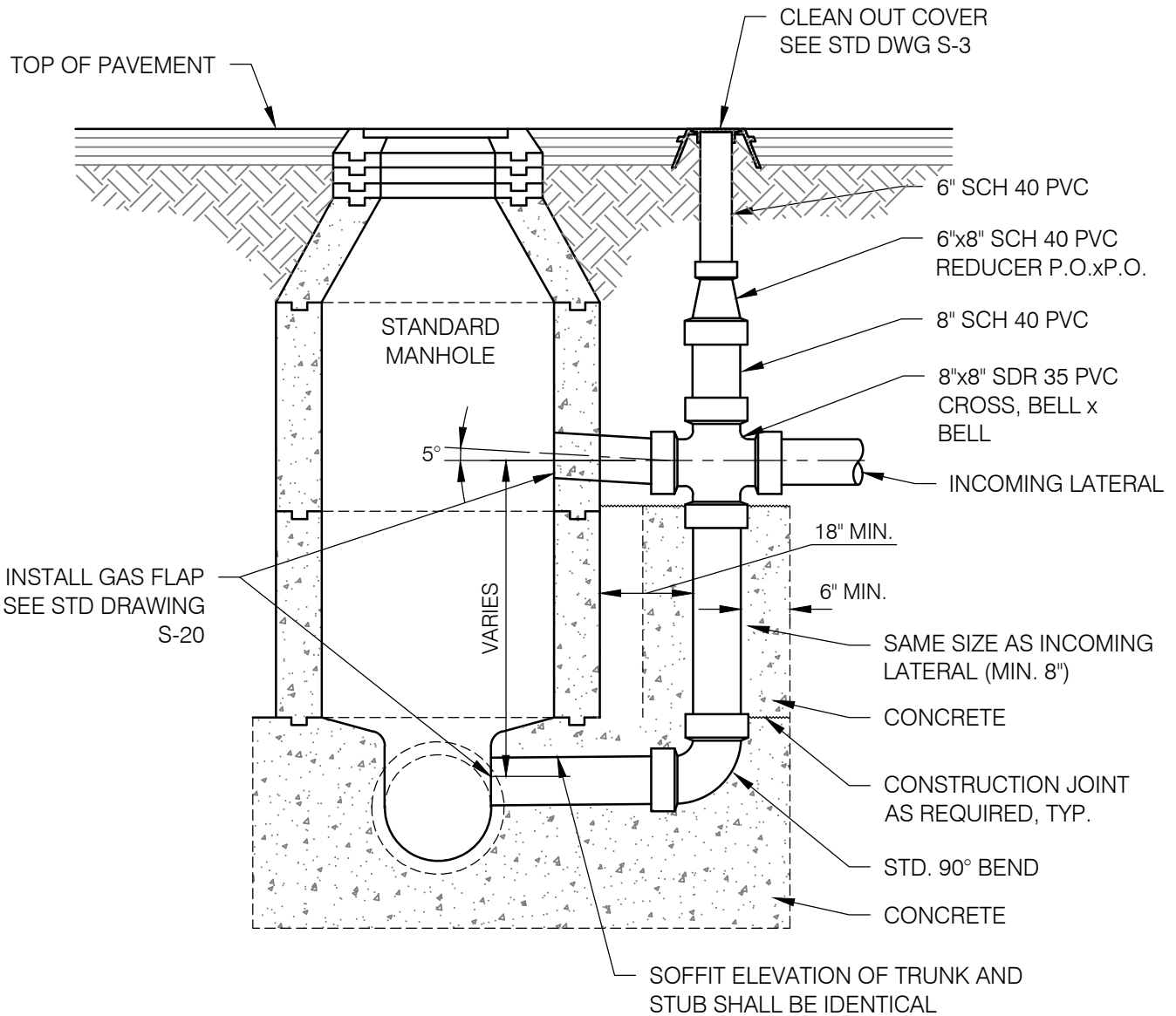

**NOTES:**

1. SEE DETAILS S-12 TO S-14 FOR STANDARD MANHOLE.
2. CONCRETE FOR DROP SECTIONS SHALL BE FORMED.
3. ALL MANHOLE PENETRATIONS SHALL BE MADE BY CORE DRILLING. INTERIOR COATING SHALL BE REPAIRED. LINER SHALL BE REPAIRED WITH 6" TURN BACK AT ALL PENETRATIONS. GAS FLAPS SHALL BE INSTALLED AT ALL PENETRATIONS 12" OR SMALLER (SEE STD. DRAWINGS S-20).
4. DROP MANHOLE CONNECTION SHALL BE USED ONLY WHERE SLOPE OF LATERAL INCOMING TO MAIN SEWER WOULD EXCEED 10% AND ONLY WITH APPROVAL OF THE ENGINEER.

9/1/2022

N:\ECC\WD\ECC\WD-2021-002 Sewer Standards Update\300 Engineering\301 CAD\Plansets\S-15.dwg

		EAST ORANGE COUNTY WATER DISTRICT ORANGE, CALIFORNIA		NO SCALE
		APPROVED BY <i>[Signature]</i>	9/1/2022	<b>DROP MANHOLE CONNECTION TO STANDARD MANHOLE</b>
		GENERAL MANAGER	DATE	
		DISTRICT ENGINEER <i>[Signature]</i>	9/1/2022	
NO.	APPROVED	DATE	DATE	S-15

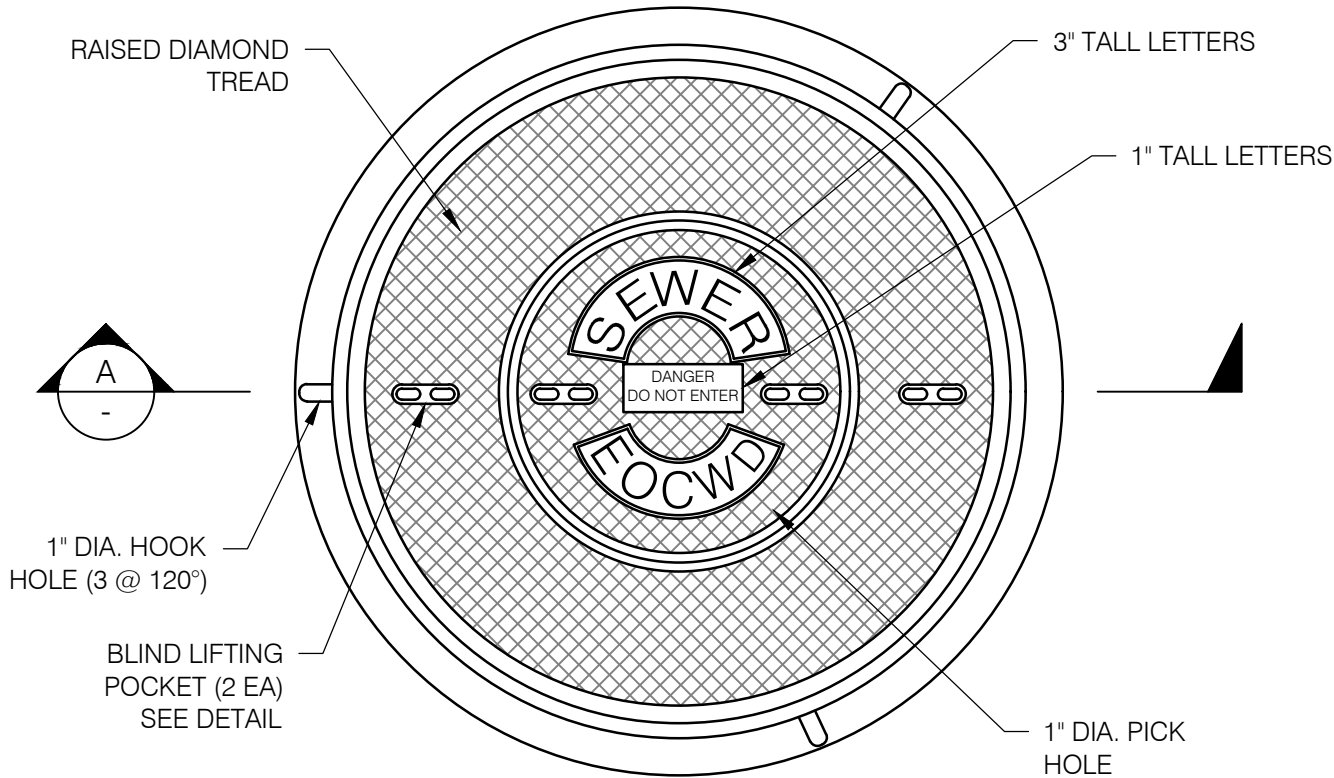

PLAN

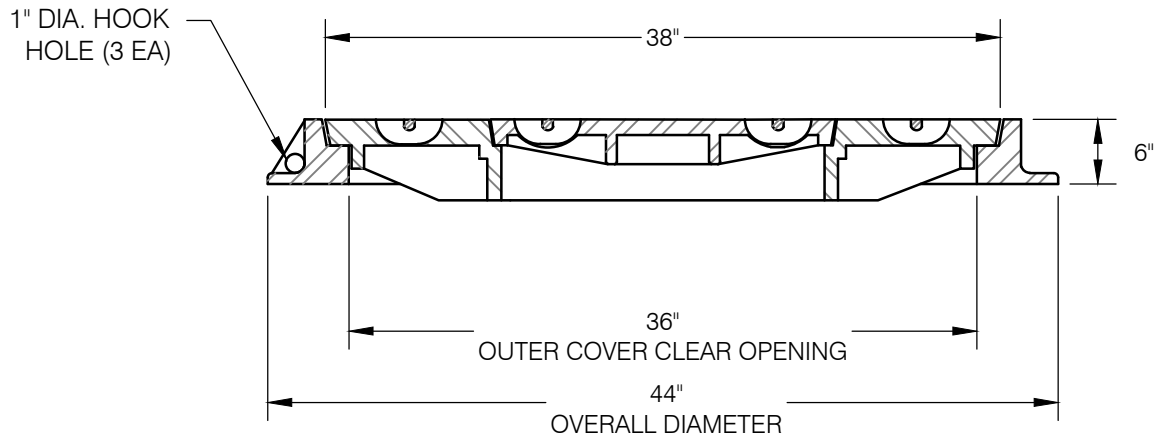

SECTION A

**NOTES:**

1. COVERS SHALL BE TRAFFIC GRADE
2. ALL CASTINGS SHALL BE COMPLETELY PAINTED WITH 6 MILS. BITUMINOUS PAINT AND LETTERED "MADE IN COUNTRY OF ORIGIN", MARKED WITH MANUFACTURER'S IDENTIFICATION "HEAT NO. \_\_\_", "ASTM A-48", AND "CLASS 35B IRON" ON UNDERSIDE OF COVER. WEIGHT OF INNER 24" COVER SHALL BE 190 LBS. MIN., WEIGHT OF OUTER 48" COVER SHALL BE 600 LBS. MIN. AND WEIGHT OF FRAME SHALL BE 600 LBS. MIN. ACTUAL WEIGHTS SHALL BE +/- 5 PERCENT OF THE MINIMUM.
3. THIS DRAWING FOR UNBOLTED 48" MANHOLE COVERS WITH CONCENTRIC 24" COVER ONLY.
4. PROVIDE 6" RIM IF REQUIRED FOR ADJUSTMENT TO GRADE.
5. THE GAP BETWEEN THE COVER AND THE RING SHALL BE APPROXIMATELY 1/8" AROUND THE ENTIRE CIRCUMFERENCE AND SHALL NOT BE GREATER THAN 1/4" WHEN THE COVER IS SLID TO ONE SIDE.

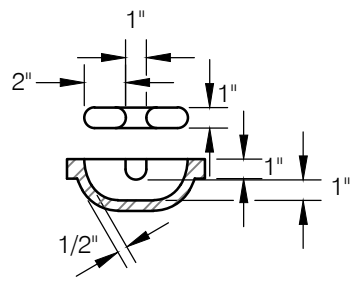

**BLIND LIFTING  
POCKET DETAIL**

9/1/2022 N:\EOCWD\EOCWD-2021-002 Sewer Standards Update\300 Engineering\301 CAD\Plansets\S-16.dwg

		EAST ORANGE COUNTY WATER DISTRICT ORANGE, CALIFORNIA		<b>36" MANHOLE FRAME AND COVER</b>	NO SCALE STANDARD DWG. <b>S-16</b>
		APPROVED BY <i>[Signature]</i>	9/1/2022		
		GENERAL MANAGER	DATE		
NO.	APPROVED	DISTRICT ENGINEER <i>[Signature]</i>	9/1/2022		
			DATE		

BLIND LIFTING  
POCKET (2 EA.)  
SEE DETAIL

RAISED DIAMOND  
TREAD

3" TALL LETTERS

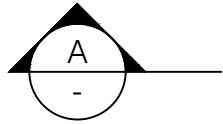

1" TALL LETTERS

1 1/2" NOTCH  
PRYHOLE OPENING

1" PICK HOLE  
LOCATED 45° FROM  
PRYHOLE OPENING



1" DIA. LIFTING  
HOOK (3 @ 120°  
OR 4 @ 90°)

PLAN

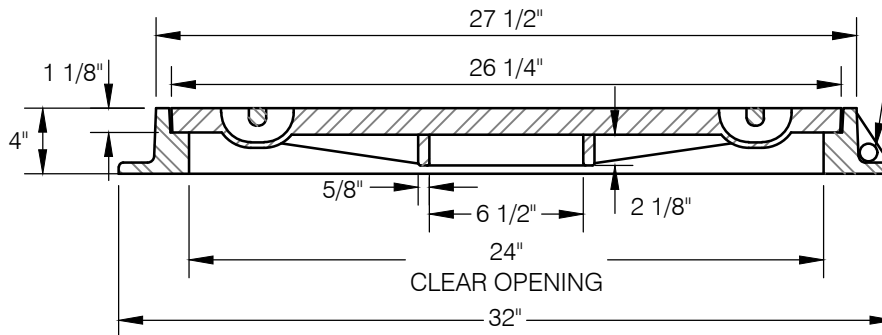

SECTION A

NOTE:

- COVERS SHALL BE TRAFFIC GRADE.
- ALL CASTINGS SHALL BE COMPLETELY PAINTED WITH 6 MILS. BITUMINOUS PAINT AND LETTERED "MADE IN COUNTRY OF ORIGIN", MARKED WITH MANUFACTURER'S IDENTIFICATION "HEAT NO. \_\_\_", "ASTM A-48", AND "CLASS 35B IRON" ON UNDERSIDE OF COVER. WEIGHT OF COVER SHALL BE 325 LBS. MIN., WEIGHT OF FRAME SHALL BE 270 LBS. MIN. ACTUAL WEIGHTS SHALL BE +/- 5 PERCENT OF THE MINIMUM.
- THIS DRAWING FOR UNBOLTED "STANDARD" MANHOLE COVERS ONLY. BOLTED COVERS, SHOWN ON A SEPARATE DRAWING, SHALL BE INSTALLED AT ALL INTERSECTIONS.
- PROVIDE 6" RIM IF REQUIRED FOR ADJUSTMENT TO GRADE.
- THE GAP BETWEEN THE COVER AND THE RING SHALL BE APPROXIMATELY 1/8" AROUND THE ENTIRE CIRCUMFERENCE AND SHALL NOT BE GREATER THAN 1/4" WHEN THE COVER IS SLID TO ONE SIDE.

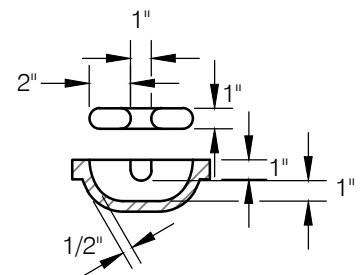

BLIND LIFTING  
POCKET DETAIL

9/1/2022

N:\ECCWID\ECCWID-2021-002 Sewer Standards Update\300 Engineering\301 CAD\Plansets\S-17\_1.dwg

NO.	APPROVED	DATE

EAST ORANGE COUNTY WATER DISTRICT ORANGE, CALIFORNIA	
APPROVED BY	<i>[Signature]</i>
GENERAL MANAGER	DATE 9/1/2022
DISTRICT ENGINEER	DATE 9/1/2022

STANDARD MANHOLE FRAME AND COVER	
1 OF 2	

NO SCALE
STANDARD DWG.
<b>S-17</b>

BLIND LIFTING  
POCKET (2 EA.)  
SEE DETAIL

RAISED DIAMOND  
TREAD

3" TALL LETTERS

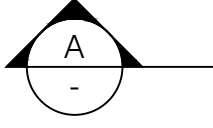

1" TALL LETTERS



1 1/2" NOTCH  
PRYHOLE OPENING

1" PICK HOLE  
LOCATED 45° FROM  
PRYHOLE OPENING

1" DIA. LIFTING  
HOOK (3 @ 120°  
OR 4 @ 90°)

PLAN

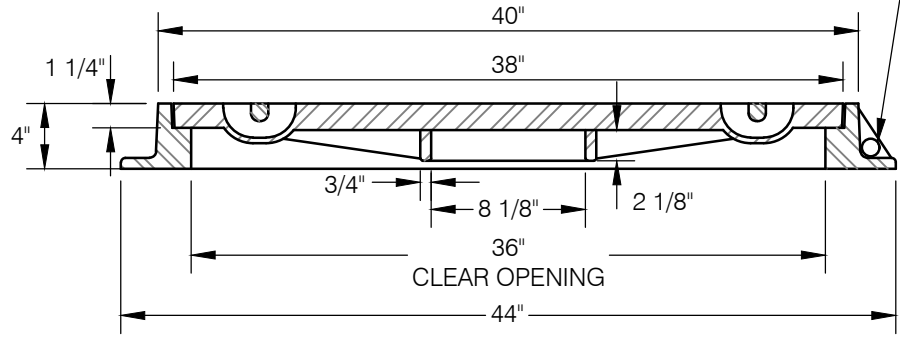

SECTION A

**NOTE:**

- COVERS SHALL BE TRAFFIC GRADE.
- ALL CASTINGS SHALL BE COMPLETELY PAINTED WITH 6 MILS. BITUMINOUS PAINT AND LETTERED "MADE IN COUNTRY OF ORIGIN", MARKED WITH MANUFACTURER'S IDENTIFICATION "HEAT NO. \_\_\_", "ASTM A-48", AND "CLASS 35B IRON" ON UNDERSIDE OF COVER. WEIGHT OF COVER SHALL BE 325 LBS. MIN., WEIGHT OF FRAME SHALL BE 270 LBS. MIN. ACTUAL WEIGHTS SHALL BE +/- 5 PERCENT OF THE MINIMUM.
- THIS DRAWING FOR UNBOLTED "STANDARD" MANHOLE COVERS ONLY. BOLTED COVERS, SHOWN ON A SEPARATE DRAWING, SHALL BE INSTALLED AT ALL INTERSECTIONS.
- PROVIDE 6" RIM IF REQUIRED FOR ADJUSTMENT TO GRADE.
- THE GAP BETWEEN THE COVER AND THE RING SHALL BE APPROXIMATELY 1/8" AROUND THE ENTIRE CIRCUMFERENCE AND SHALL NOT BE GREATER THAN 1/4" WHEN THE COVER IS SLID TO ONE SIDE.

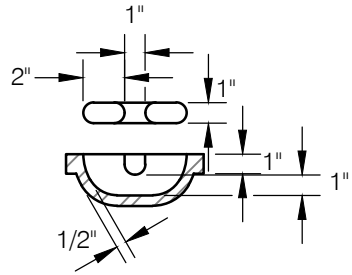

BLIND LIFTING  
POCKET DETAIL

9/1/2022 N:\ECCWID\ECCWID-2021-002 Sewer Standards Update\300 Engineering\301 CAD\Plansets\S-17\_2.dwg

			EAST ORANGE COUNTY WATER DISTRICT ORANGE, CALIFORNIA		STANDARD MANHOLE FRAME AND COVER		NO SCALE	
			APPROVED BY	9/1/2022			STANDARD DWG.	
			GENERAL MANAGER	DATE	2 OF 2		S-17	
NO.	APPROVED	DATE	DISTRICT ENGINEER	DATE				

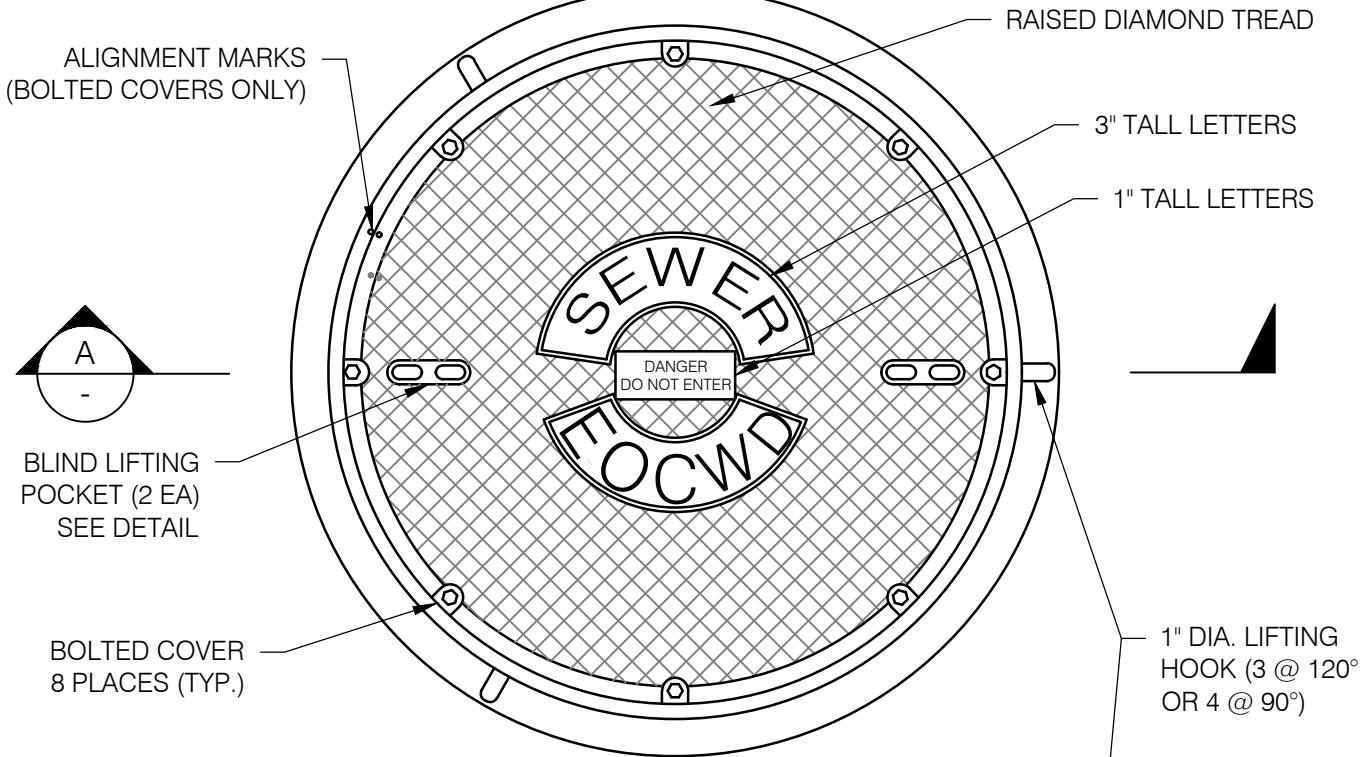

PLAN

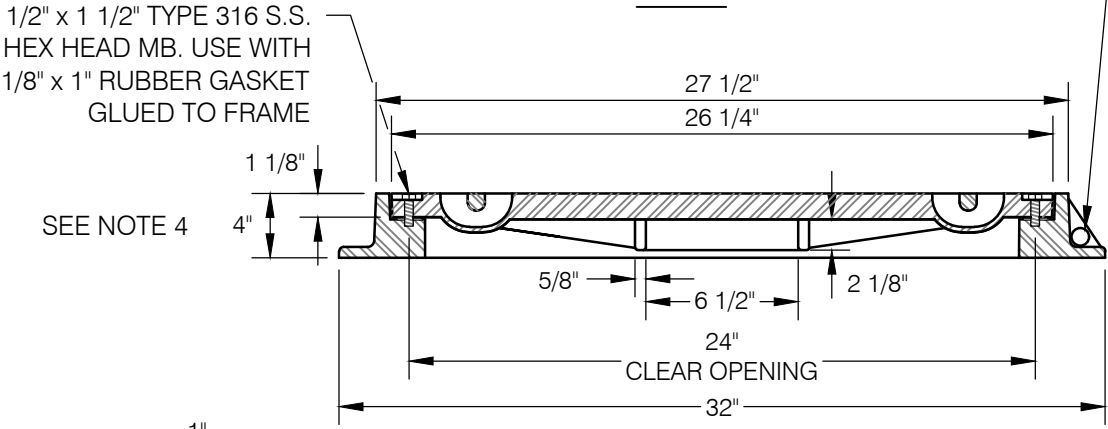

SECTION A

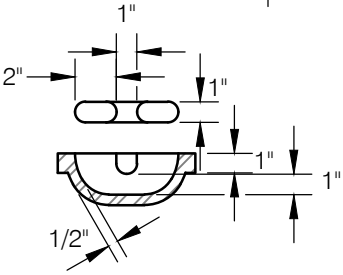

BLIND LIFTING POCKET DETAIL

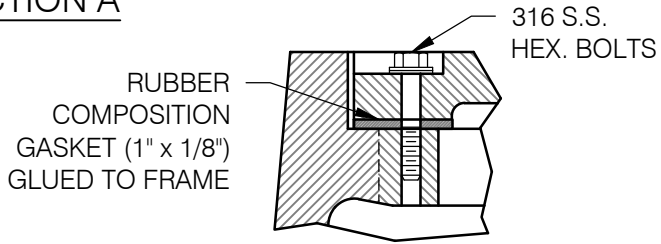

BOLTING/Self-SEAL DETAIL

NOTES:

- COVERS SHALL BE TRAFFIC GRADE.
- ALL CASTINGS SHALL BE COMPLETELY PAINTED WITH 6 MILS. BITUMINOUS PAINT AND LETTERED "MADE IN COUNTRY OF ORIGIN", MARKED WITH MANUFACTURER'S IDENTIFICATION "HEAT NO. \_\_\_", "ASTM A-48", AND "CLASS 35B IRON" ON UNDERSIDE OF COVER. WEIGHT OF COVER SHALL BE 325 LBS. MIN., WEIGHT OF FRAME SHALL BE 270 LBS. MIN. ACTUAL WEIGHTS SHALL BE +/- 5 PERCENT OF THE MINIMUM.
- BOLTED COVERS SHALL BE INSTALLED AT ALL INTERSECTIONS.
- PROVIDE 6" RIM IF REQUIRED FOR ADJUSTMENT TO GRADE.
- THE GAP BETWEEN THE COVER AND THE RING SHALL BE APPROXIMATELY 1/8" AROUND THE ENTIRE CIRCUMFERENCE AND SHALL NOT BE GREATER THAN 1/4" WHEN THE COVER IS SLID TO ONE SIDE.

9/1/2022  
N:\EOCWD\EOCWD-2021-002 Sewer Standards Update\300 Engineering\301 CAD\Plansets\S-18\_1.dwg

NO.	APPROVED	DATE

EAST ORANGE COUNTY WATER DISTRICT ORANGE, CALIFORNIA	
APPROVED BY	<i>[Signature]</i>
GENERAL MANAGER	9/1/2022
DISTRICT ENGINEER	DATE
<i>[Signature]</i>	9/1/2022
	DATE

**BOLTED MANHOLE FRAME AND COVER**  
1 OF 2

NO SCALE  
STANDARD DWG.  
**S-18**

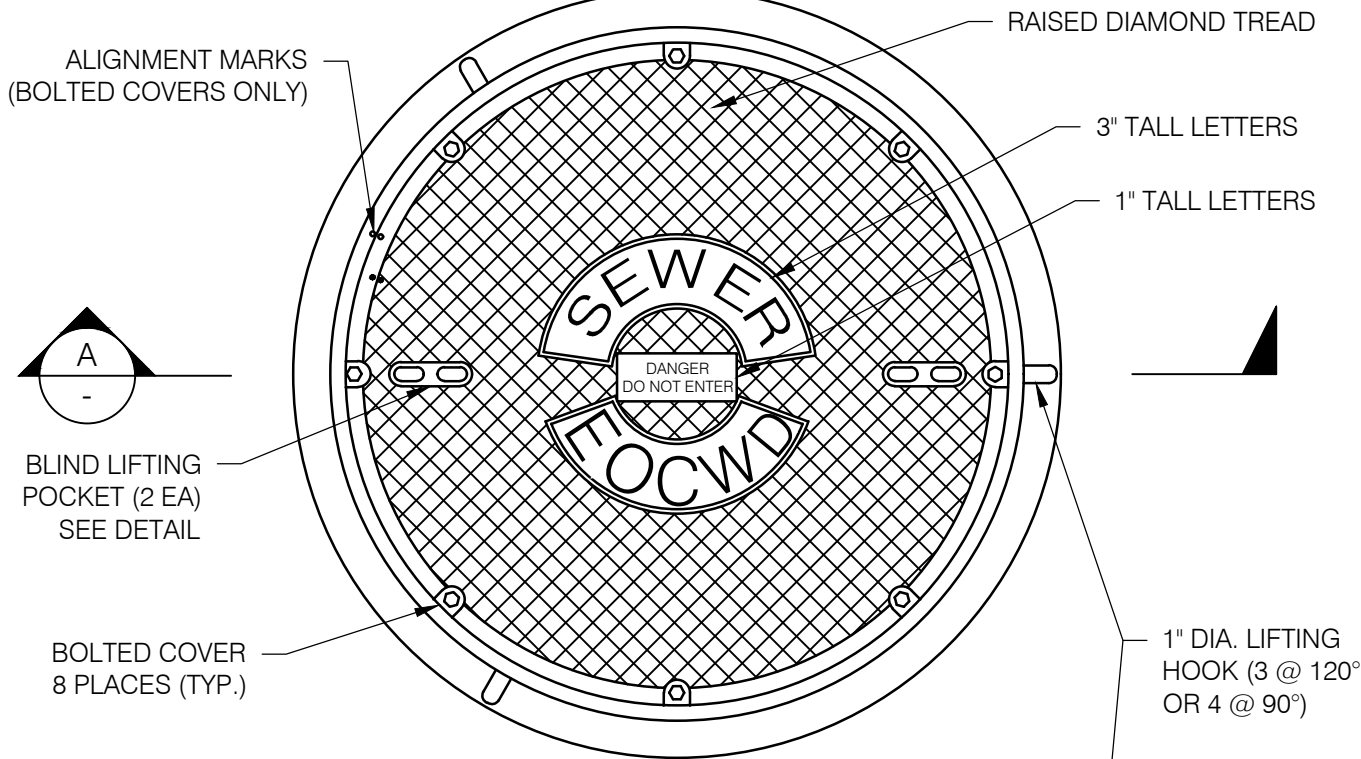

PLAN

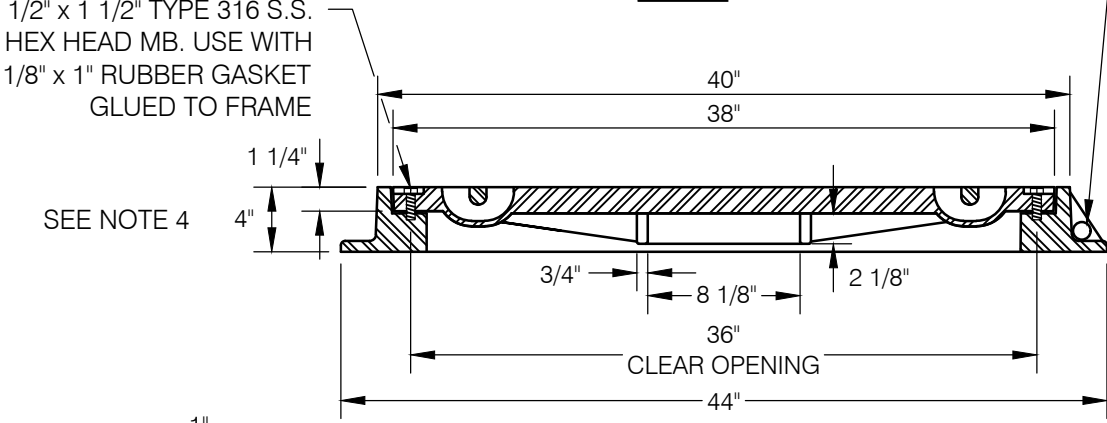

SECTION A

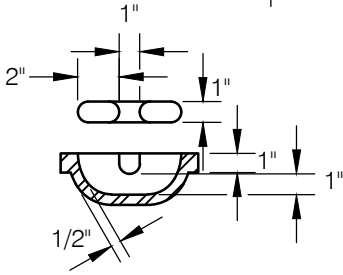

BLIND LIFTING POCKET DETAIL

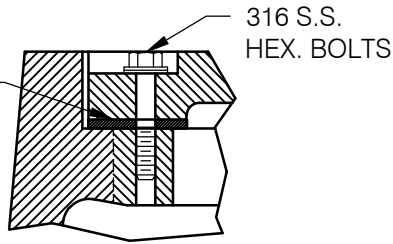

BOLTING/Self-SEAL DETAIL

NOTES:

- COVERS SHALL BE TRAFFIC GRADE.
- ALL CASTINGS SHALL BE COMPLETELY PAINTED WITH 6 MILS. BITUMINOUS PAINT AND LETTERED "MADE IN COUNTRY OF ORIGIN", MARKED WITH MANUFACTURER'S IDENTIFICATION "HEAT NO. \_\_\_", "ASTM A-48", AND "CLASS 35B IRON" ON UNDERSIDE OF COVER. WEIGHT OF COVER SHALL BE 325 LBS. MIN., WEIGHT OF FRAME SHALL BE 270 LBS. MIN. ACTUAL WEIGHTS SHALL BE +/- 5 PERCENT OF THE MINIMUM.
- BOLTED COVERS SHALL BE INSTALLED AT ALL INTERSECTIONS.
- PROVIDE 6" RIM IF REQUIRED FOR ADJUSTMENT TO GRADE.
- THE GAP BETWEEN THE COVER AND THE RING SHALL BE APPROXIMATELY 1/8" AROUND THE ENTIRE CIRCUMFERENCE AND SHALL NOT BE GREATER THAN 1/4" WHEN THE COVER IS SLID TO ONE SIDE.

9/1/2022 N:\ECC\WID\EOCWD-2021-002 Sewer Standards Update\300 Engineering\301 CAD\Plansets\S-18\_2.dwg

NO.	APPROVED	DATE

EAST ORANGE COUNTY WATER DISTRICT ORANGE, CALIFORNIA	
APPROVED BY	<i>[Signature]</i>
GENERAL MANAGER	9/1/2022
DISTRICT ENGINEER	DATE
	9/1/2022
	DATE

**BOLTED MANHOLE FRAME  
AND COVER**  
2 OF 2

NO SCALE  
STANDARD DWG.  
**S-18**

9/1/2022

N:\ECC\DWG\ECC\2021-002 Sewer Standards Update\300 Engineering\301 CAD\Plansets\S-19.dwg

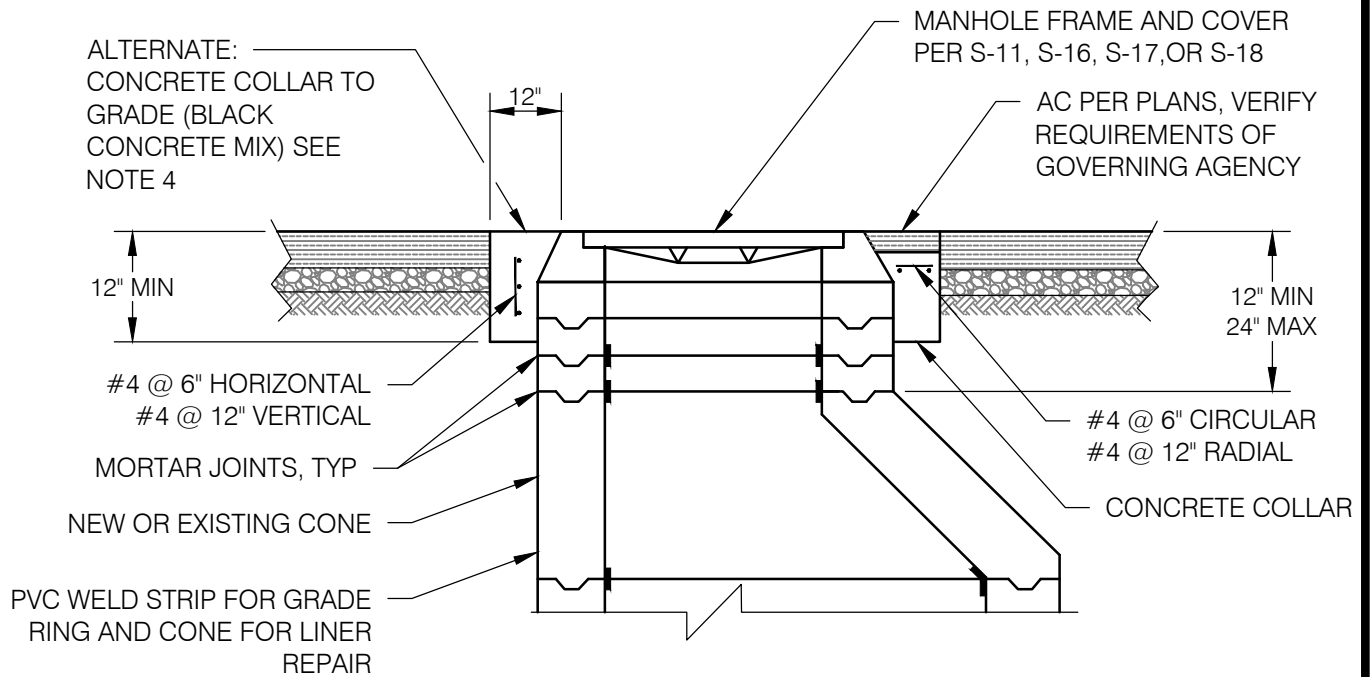

CROSS SECTION

NOTES:

1. NEATLY REMOVE PAVEMENT AND AGGREGATE BASE AS NECESSARY TO MAKE ADJUSTMENT.
2. MAKE FINAL ADJUSTMENTS AT THE MORTAR JOINT BETWEEN THE FIRST AND SECOND GRADE RINGS. SET FLUSH WITH PAVEMENT TO 1/8" HIGH.
3. AT EXISTING MANHOLES, ADD OR REMOVE GRADE RINGS, REPAIR LINER, AND TEST LINER FOR PINHOLES AS APPROVED BY THE ENGINEER. ADJUST HEIGHT AT MANHOLE RISER SECTIONS IF THE TOTAL HEIGHT OF GRADE RINGS WOULD EXCEED 24".
4. BACKFILL FLUSH WITH SURFACE OR BELOW PAVEMENT SURFACE AS REQUIRED BY GOVERNING AGENCY WITH 3250 PSI (CLASS B) QUICK-SETTING CONCRETE TO FORM COLLAR. EXPOSED CONCRETE SHALL BE BLACK IN COLOR.
5. FILL AREA ABOVE BELOW-GRADE COLLAR WITH AC WEARING SURFACE TO MATCH ADJACENT AC.
6. WHERE ODOR CONDITIONS EXIST OR WHERE DESIGNATED, SEAL MANHOLE RIM AND HOLES WITH DUCT-SEAL MASTIC. RE-SEAL IF EXISTING MANHOLE COVER WAS SEALED.

NO.	APPROVED	DATE

EAST ORANGE COUNTY WATER DISTRICT ORANGE, CALIFORNIA	
APPROVED BY	<i>[Signature]</i>
GENERAL MANAGER	9/1/2022 DATE
DISTRICT ENGINEER	<i>[Signature]</i>
	9/1/2022 DATE

**MANHOLE ADJUSTMENT TO  
GRADE**

NO SCALE
STANDARD DWG.
<b>S-19</b>

9/1/2022

N:\EOC\WD\EOCWD-2021-002 Sewer Standards Update\300 Engineering\301 CAD\Plansets\S-20\_1.dwg

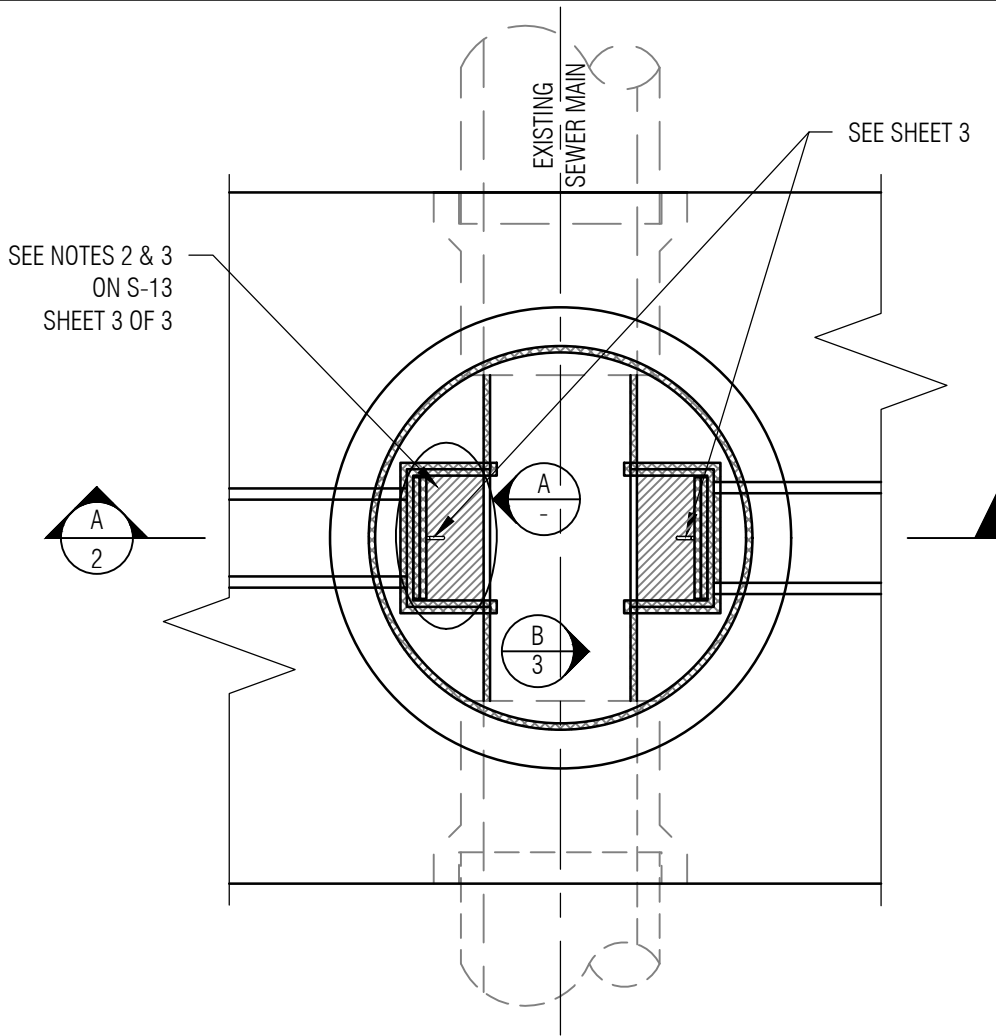

PLAN VIEW

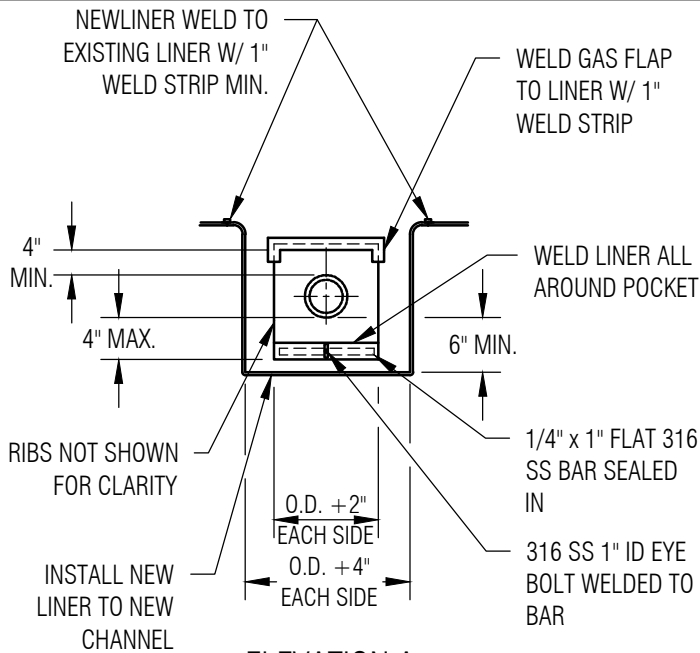

ELEVATION A  
LINED MH

NO.	APPROVED	DATE

EAST ORANGE COUNTY WATER DISTRICT  
ORANGE, CALIFORNIA

APPROVED BY *[Signature]* 9/1/2022  
DATE

GENERAL MANAGER *[Signature]* 9/1/2022  
DATE

DISTRICT ENGINEER *[Signature]* 9/1/2022  
DATE

**GAS FLAP INSTALLATION FOR  
LINED OR UNLINED  
MANHOLES 1 OF 2**

NO SCALE  
STANDARD DWG.  
**S-20**

9/1/2022

N:\ECC\DWG\ECOCWD-2021-002 Sewer Standards Update\300 Engineering\301 CAD\Plansets\S-20\_2 - 2 OF 3.dwg

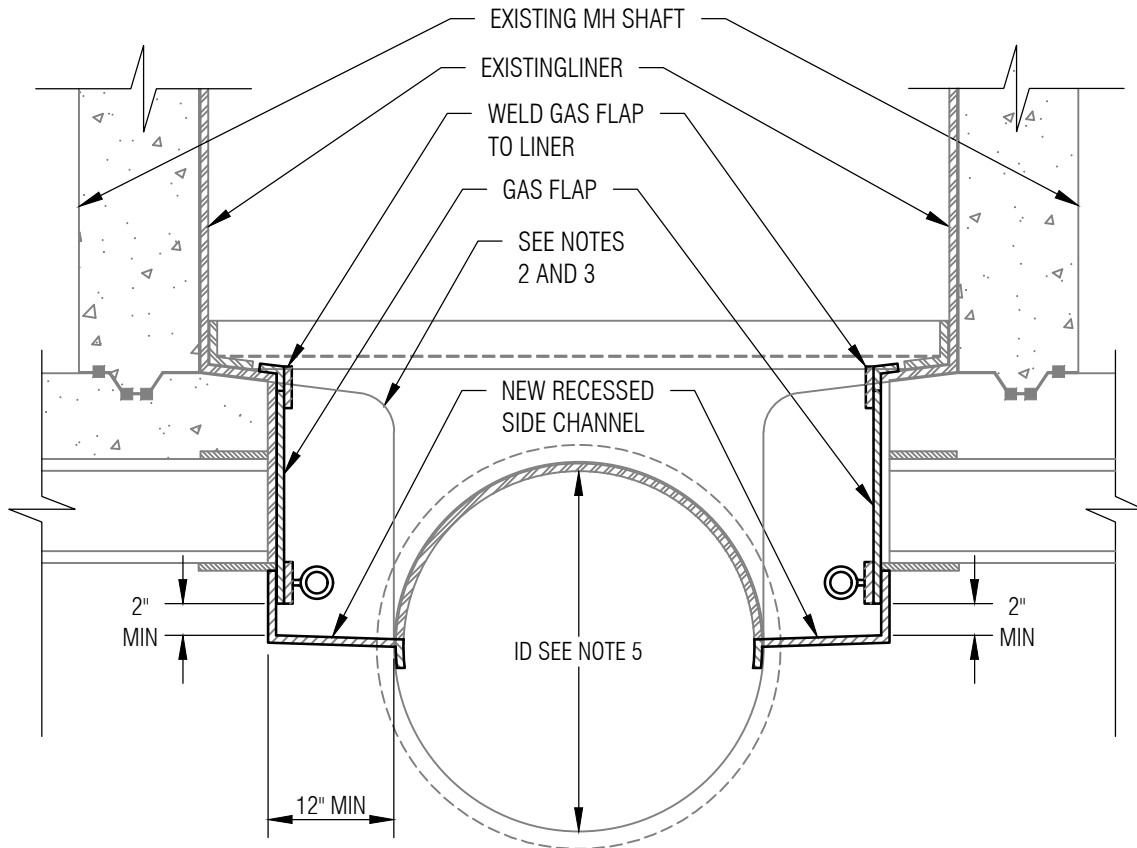

**SECTION A**

**NOTES:**

1. CORE DRILL EXISTING MH BASE A MIN. OF 2" LARGER THAN OUTSIDE DIAMETER (OD) OF NEW STUB AND DRY PACK W/ CONCRETE GROUT AROUND OUTSIDE OF NEW STUB AS SHOWN.
2. REMOVE EXISTING LINER OVER EXISTING MANHOLE SHELF. JACK HAMMER OR REMOVE PORTIONS OF EXISTING CONCRETE BASE TO FORM NEW RECESSED CHANNEL A MIN. OF 2" IN WIDTH (ON EACH SIDE) BEYOND EDGE OF NEW GAS FLAP; OR FOR NEW STUBS 15" OR GREATER IN DIAMETER, REMOVE A MIN. 4" IN WIDTH (ON EACH SIDE) GREATER THAN OD OF NEW STUB. PATCH BOTTOM AND SIDES OF RECESSED CHANNEL W/ CONCRETE OR GROUT TO MAKE A SMOOTH TRANSITION ON SIDES AND BOTTOM OF CHANNEL.
3. INSTALL NEW LINER IN RECESSED CHANNEL AREA OVER FRESHLY CURED CONCRETE AND IN ALL OTHER AREAS WHERE EXISTING LINER WAS REMOVED. WELD STRIPS SHALL BE USED TO PATCH ALL JOINTS.
4. PROVIDE GAS FLAP ON ALL LATERAL PIPES 12" IN DIA. AND LESS UNLESS OTHERWISE SPECIFIED.

NO.	APPROVED	DATE

EAST ORANGE COUNTY WATER DISTRICT ORANGE, CALIFORNIA	
APPROVED BY	
GENERAL MANAGER	9/1/2022 DATE
DISTRICT ENGINEER	9/1/2022 DATE

**GAS FLAP INSTALLATION FOR  
LINED OR UNLINED  
MANHOLES 2 OF 3**

NO SCALE
STANDARD DWG.
<b>S-20</b>

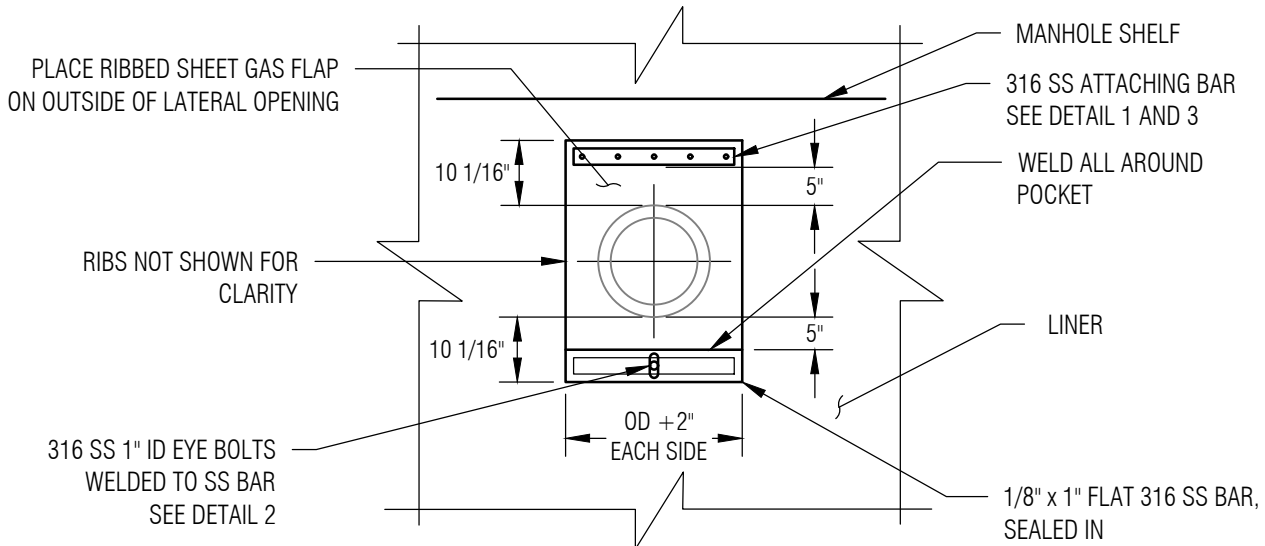

**ELEVATION B**

**NOTES:**

1. FOR INSTALLATION AT EXISTING MANHOLE, SEE STD DWG. S-21.
2. FOR MANHOLES WITHOUT LINER, ATTACH GAS FLAP W/ 1/4" x 1" 316 SS FLAT BAR. DRILL HOLES 1/2" FROM EACH END AND ONE IN THE CENTER. (A= 3" OR LESS) SPACE OTHER HOLES 3" OR LESS.
3. PROVIDE GAS FLAP FOR ALL LATERALS 12" AND LESS, UNLESS OTHERWISE SPECIFIED.

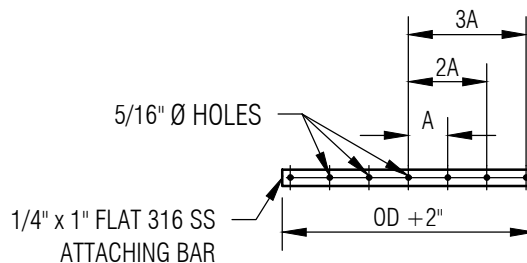

**DETAIL 3**  
ATTACHING BAR  
SEE NOTE 2

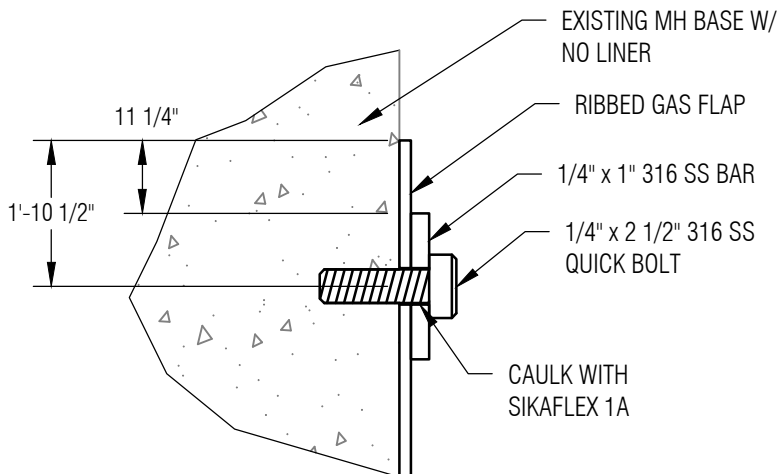

**DETAIL 1**

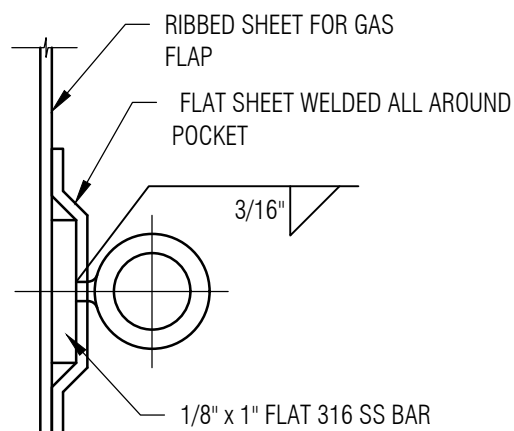

**DETAIL 2**

9/1/2022  
N:\EOC\DWG\EOC\2021-002 Sewer Standards Update\300 Engineering\301 CAD\Plansets\S-20\_3 - 3 OF 3.dwg

NO.	APPROVED	DATE

EAST ORANGE COUNTY WATER DISTRICT ORANGE, CALIFORNIA	
APPROVED BY	<i>[Signature]</i>
GENERAL MANAGER	9/1/2022
DISTRICT ENGINEER	DATE
	9/1/2022
	DATE

**GAS FLAP INSTALLATION FOR  
LINED OR UNLINED  
MANHOLES 3 OF 3**

NO SCALE
STANDARD DWG.
<b>S-20</b>

9/1/2022

N:\EOC\DWG\EOC\2021-002 Sewer Standards Update\300 Engineering\301 CAD\Plansets\S-21\_1\_1 OF 2.dwg

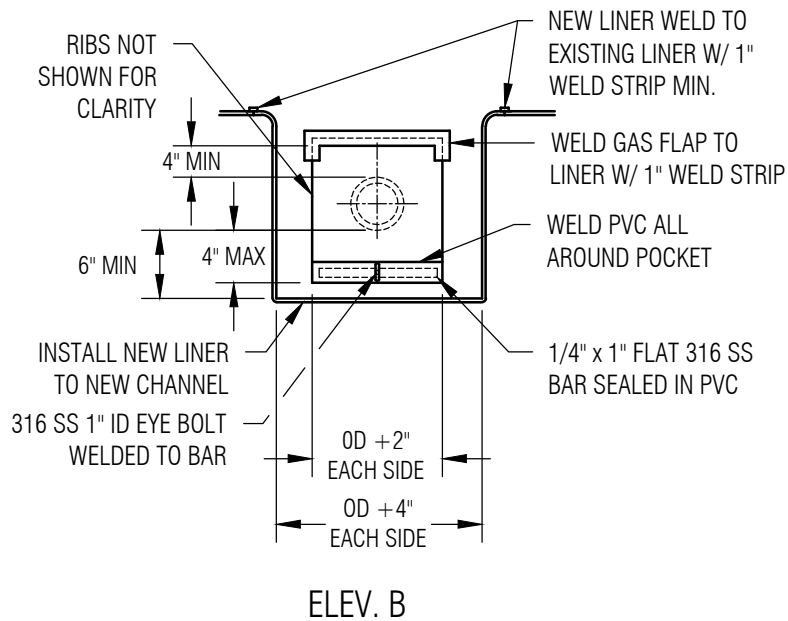
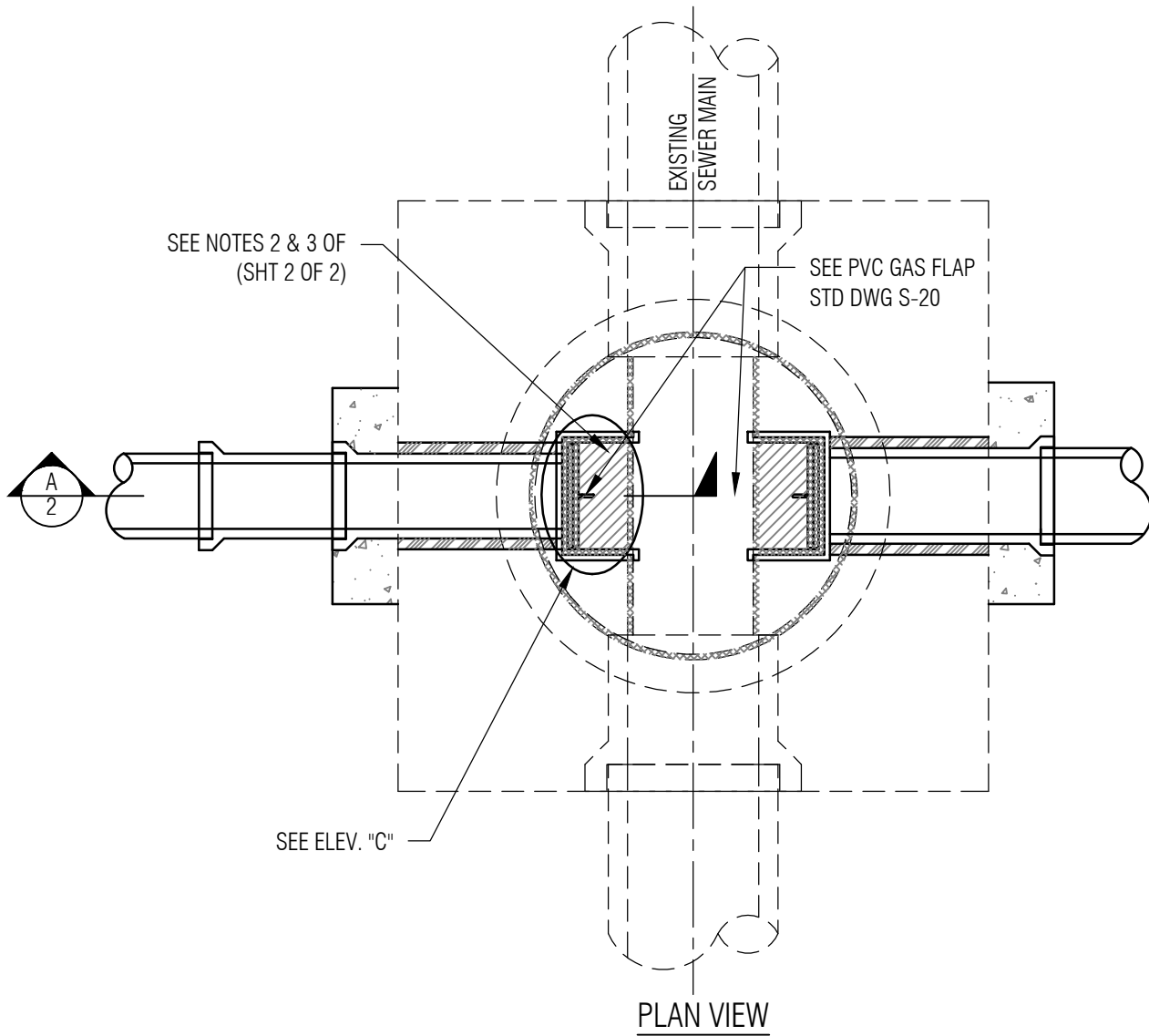

ELEV. B

NO.	APPROVED	DATE

EAST ORANGE COUNTY WATER DISTRICT  
ORANGE, CALIFORNIA

APPROVED BY *[Signature]* 9/1/2022  
DATE

GENERAL MANAGER *[Signature]* 9/1/2022  
DATE

DISTRICT ENGINEER *[Signature]* 9/1/2022  
DATE

**CORE DRILLED STUB AT  
EXISTING MANHOLE DETAIL**

1 OF 2

NO SCALE  
STANDARD DWG.  
**S-21**

9/1/2022

N:\ECCWID\EOCWD-2021-002 Sewer Standards Update\300 Engineering\301 CAD\Plansets\S-21\_2 - 2 OF 2.dwg

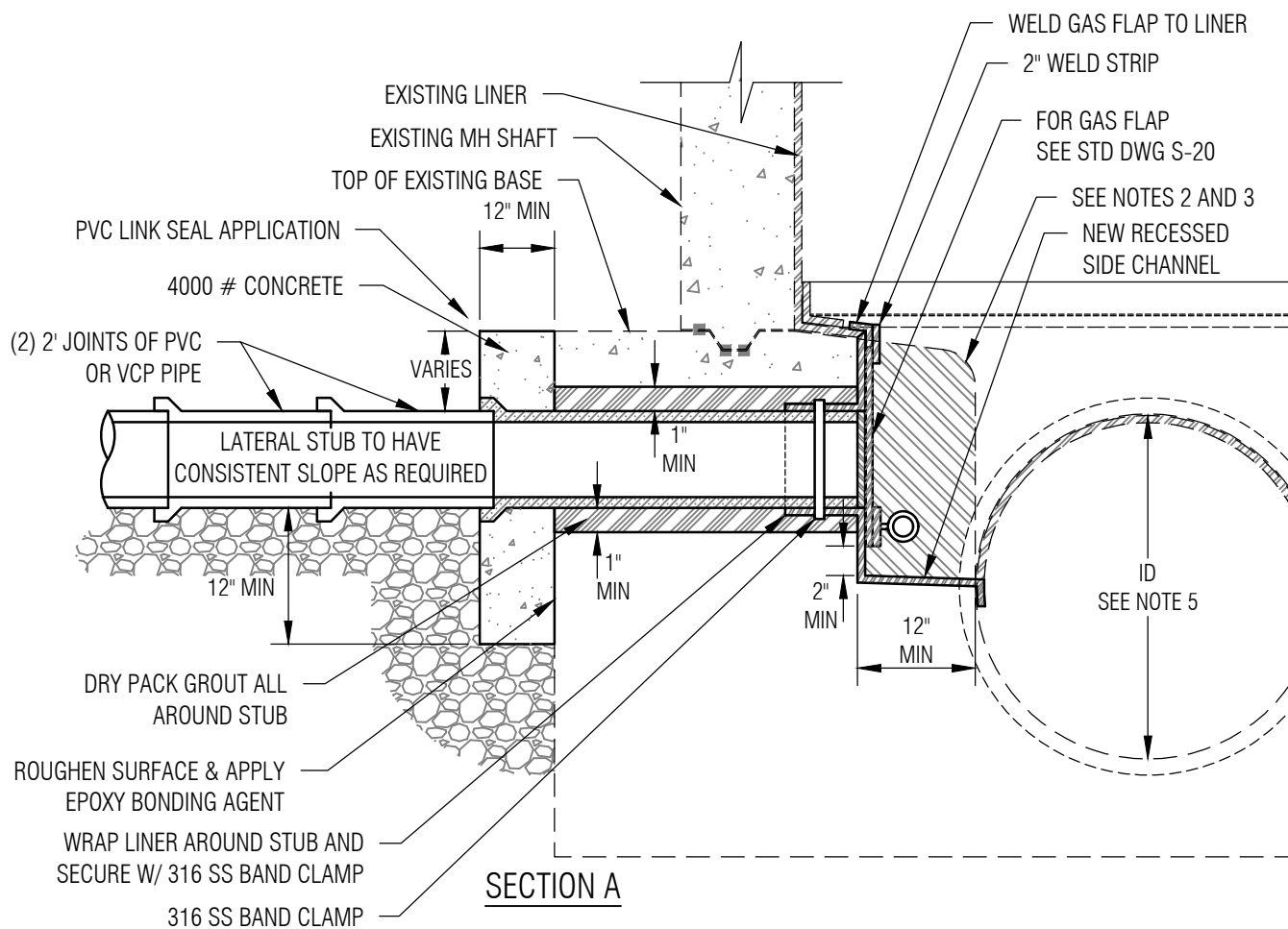

**NOTES:**

1. CORE DRILL EXISTING MH BASE A MIN. OF 2 INCHES LARGER THAN OUTSIDE DIAMETER (OD) OF NEW STUB AND DRY PACK W/ CONCRETE GROUT AROUND OUTSIDE OF NEW STUB AS SHOWN.
2. REMOVE EXISTING LINER OVER EXISTING MH SHELF. JACK HAMMER OR REMOVE PORTIONS OF EXISTING CONCRETE BASE TO FORM NEW RECESSED CHANNEL A MIN. OF 2 INCHES IN WIDTH (ON EACH SIDE) BEYOND EDGE OF NEW GAS FLAP; OR FOR NEW STUBS 15 INCHES OR GREATER IN DIAMETER, REMOVE A MIN. 4 INCHES IN WIDTH (ON EACH SIDE) GREATER THAN OD OF NEW STUB. PATCH BOTTOM AND SIDES OF RECESSED CHANNEL W/ CONCRETE OR GROUT TO MAKE A SMOOTH TRANSITION ON SIDES AND BOTTOM OF CHANNEL.
3. INSTALL NEW LINER IN RECESSED CHANNEL AREA OVER FRESHLY CURED CONCRETE AND IN ALL OTHER AREAS WHERE EXISTING LINER WAS REMOVED. WELD STRIPS SHALL BE USED TO PATCH ALL JOINTS.
4. PROVIDE FLAT SHEET GAS FLAP ON ALL LATERAL PIPES 12 INCHES IN DIA. AND LESS UNLESS OTHERWISE SPECIFIED. SEE STANDARD DRAWING S-20.

		EAST ORANGE COUNTY WATER DISTRICT ORANGE, CALIFORNIA		<b>CORE DRILLED STUB AT EXISTING MANHOLE DETAIL</b>	NO SCALE STANDARD DWG.
		APPROVED BY <i>[Signature]</i>	9/1/2022	<b>2 OF 2</b>	<b>S-21</b>
		GENERAL MANAGER	DATE		
NO.	APPROVED	DISTRICT ENGINEER <i>[Signature]</i>	9/1/2022		
			DATE		

9/1/2022

N:\ECC\WD\EOCWD-2021-002 Sewer Standards Update\300 Engineering\301 CAD\Plansets\S-22-1.dwg

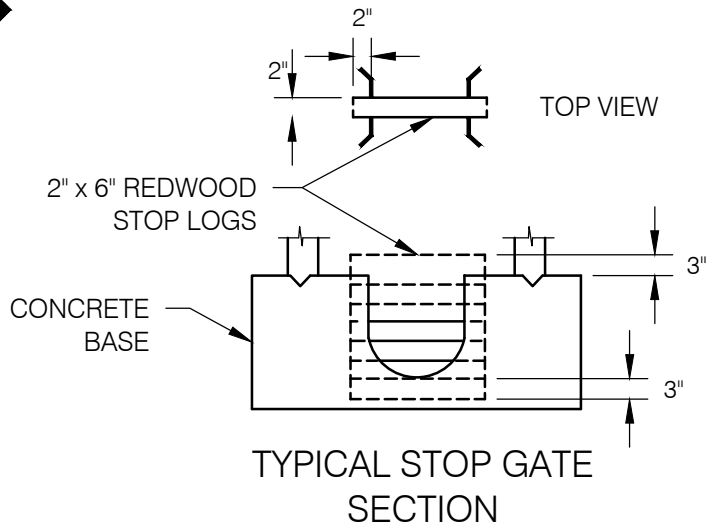
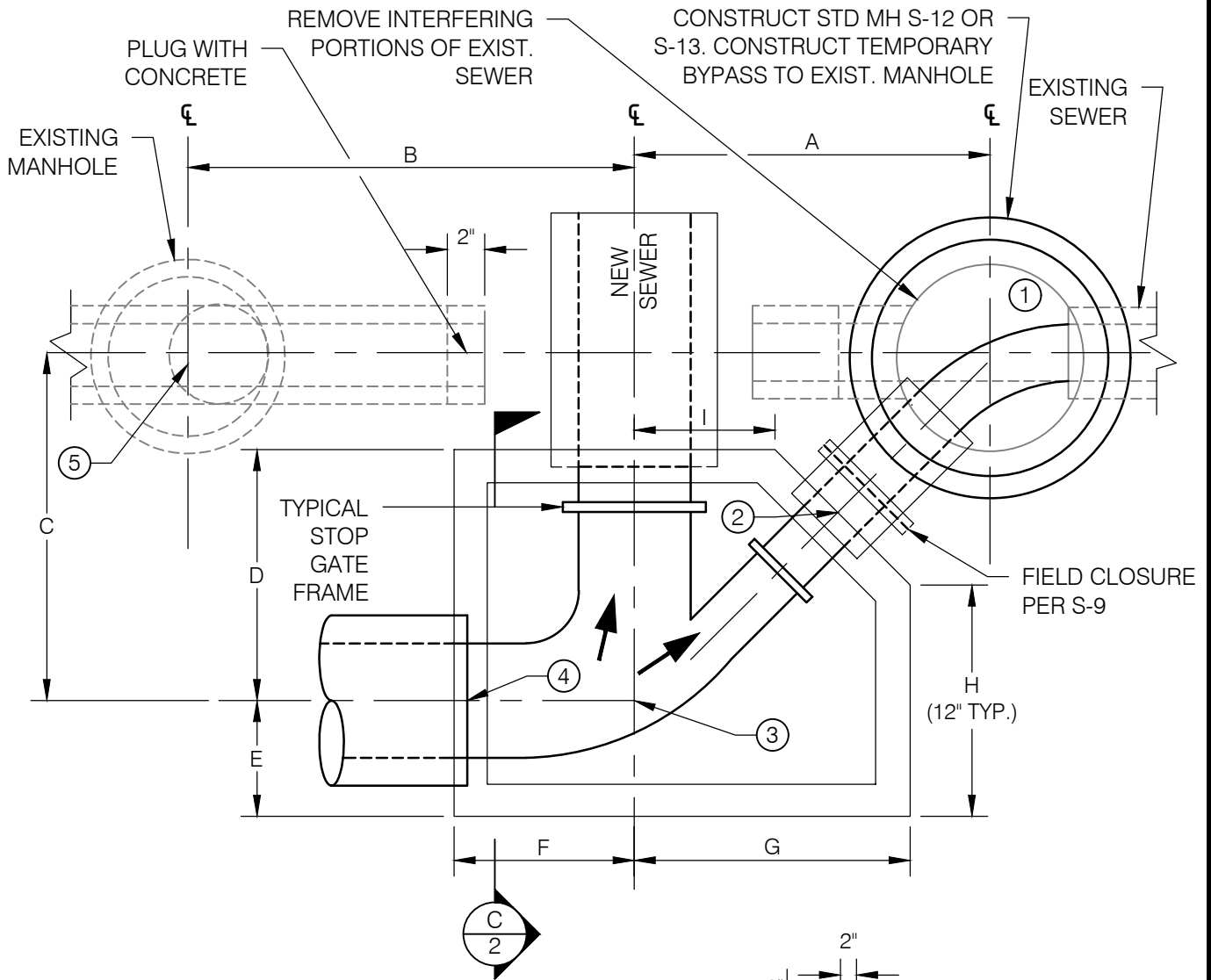

**NOTES:**

1. DIMENSIONS A, B, C, D, E, F, G, H, AND I SHALL BE AS SHOWN ON THE PLANS.
2. ELEVATIONS ①, ②, ③, ④, AND ⑤ SHALL BE AS SHOWN ON PLANS.
3. TYPICAL STOP GATE SHALL BE INCLUDED IN ALL DIVERSION STRUCTURE INSTALLATIONS.
4. FOR SECTIONS, SEE SHEET 2 OF 2.

NO.	APPROVED	DATE

EAST ORANGE COUNTY WATER DISTRICT ORANGE, CALIFORNIA	
APPROVED BY	<i>[Signature]</i>
GENERAL MANAGER	9/1/2022
DISTRICT ENGINEER	DATE
	9/1/2022
	DATE

**DIVERSION STRUCTURE  
WITH STOP GATE  
SHEET 1 OF 2**

NO SCALE
STANDARD DWG.
<b>S-22</b>



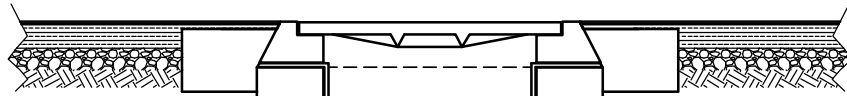

REPRESENTATIVE LARGE (> 1/2") PVC LINER DETERIORATION. REPAIR PER DETAIL A ON SHEET 3

REPRESENTATIVE PVC WELD/ANGLE STRIP DETERIORATION. REPAIR PER DETAIL C ON SHEET 4

REPLACE PVC GAS FLAP (WHERE OCCURS) PER S-20

REPRESENTATIVE SMALL (1/2" MAX) PVC LINER DETERIORATION. REPAIR PER DETAIL B ON SHEET 3

PRESSURE WASH MH PRIOR TO INSPECTION AND REPAIRS

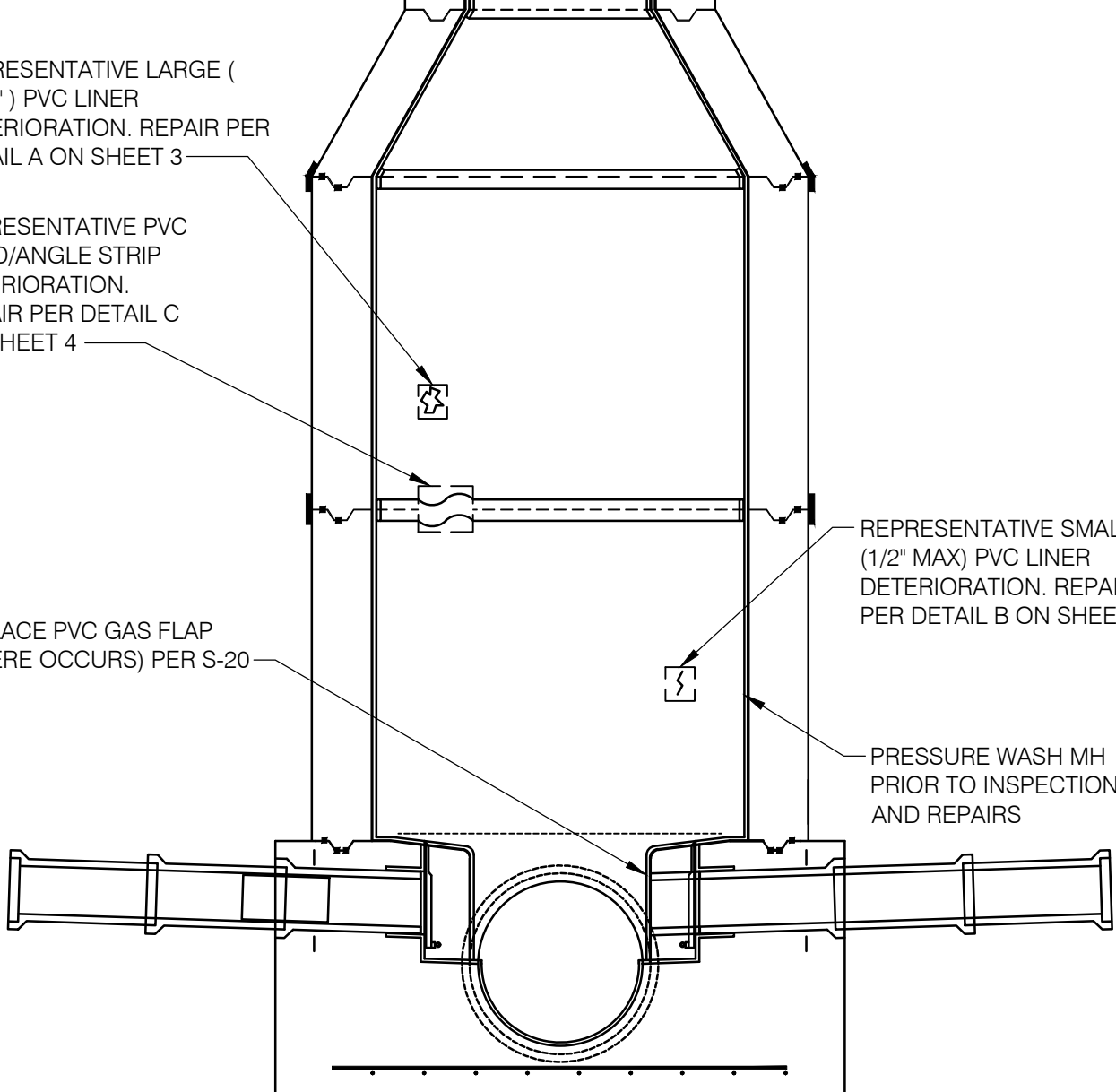

9/1/2022

N:\ECC\DWG\ECC\2021-002 Sewer Standards Update\300 Engineering\301 CAD\Plansets\S-23-1.dwg

NO.	APPROVED	DATE

EAST ORANGE COUNTY WATER DISTRICT  
ORANGE, CALIFORNIA

APPROVED BY *[Signature]* 9/1/2022  
DATE

GENERAL MANAGER

DISTRICT ENGINEER *[Signature]* 9/1/2022  
DATE

REHABILITATION OF PVC  
LINED MANHOLES  
1 OF 4

NO SCALE  
STANDARD DWG.  
**S-23**

AMER-PLATE SHEET TYP

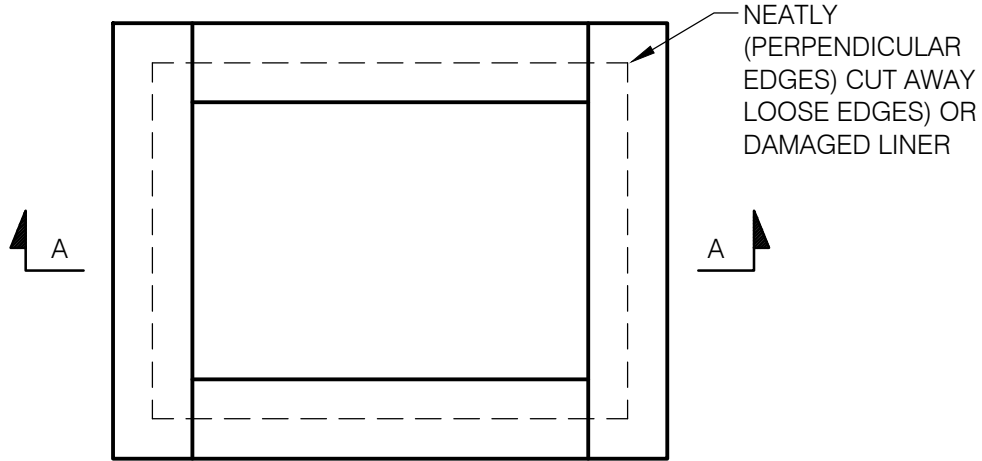

**DETAIL A**  
**REPAIR DETAIL FOR LARGE HOLE IN PVC LINING**

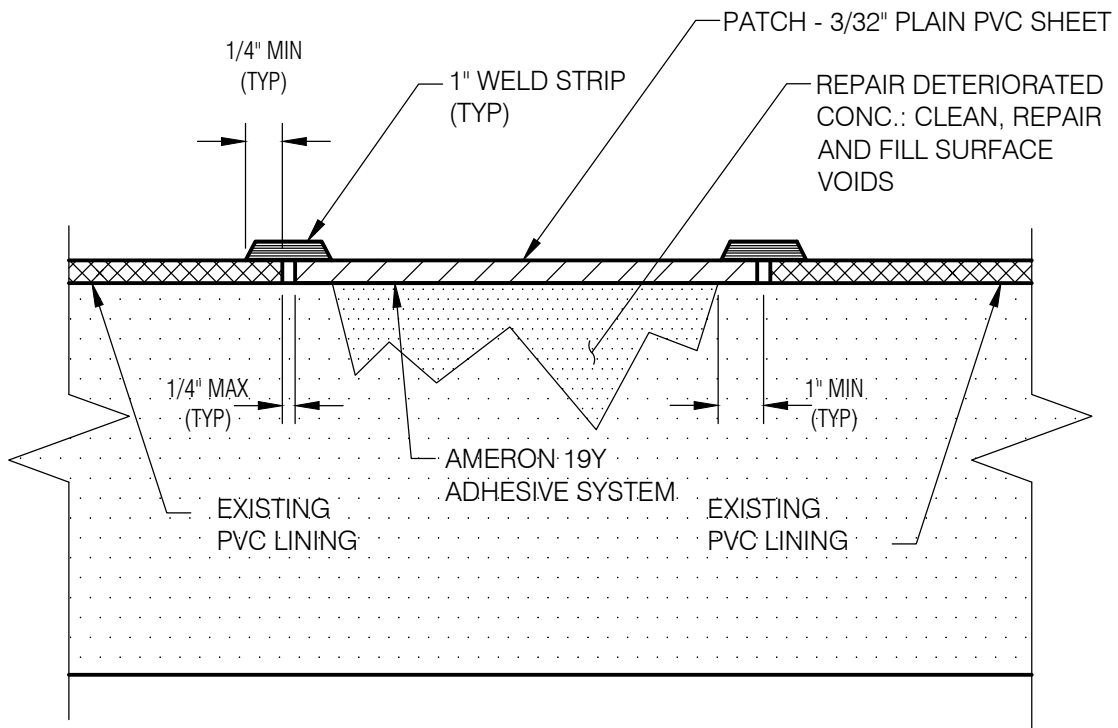

**SECTION A-A**

9/1/2022

N:\ECC\WD\ECOCWD-2021-002 Sewer Standards Update\300 Engineering\301 CAD\Plansets\S-23-2.dwg

NO.	APPROVED	DATE

EAST ORANGE COUNTY WATER DISTRICT ORANGE, CALIFORNIA	
APPROVED BY	<i>[Signature]</i>
GENERAL MANAGER	9/1/2022 DATE
DISTRICT ENGINEER	<i>[Signature]</i> 9/1/2022 DATE

REHABILITATION OF PVC  
 LINED MANHOLES  
 2 OF 4

NO SCALE  
 STANDARD DWG.  
**S-23**

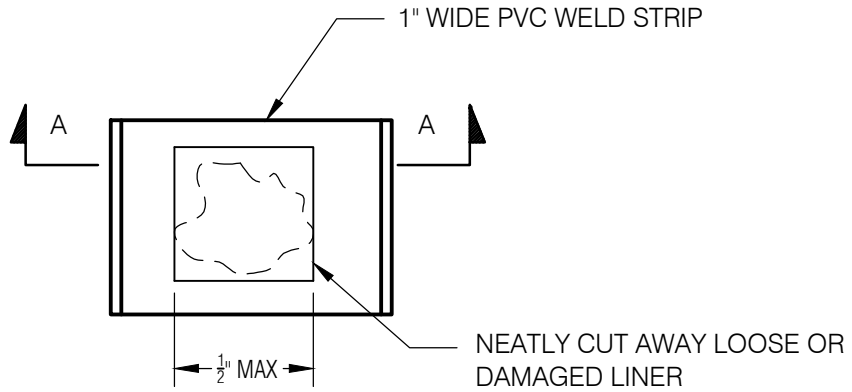

**DETAIL B**  
**REPAIR DETAIL FOR SMALL HOLE IN PVC LINING**

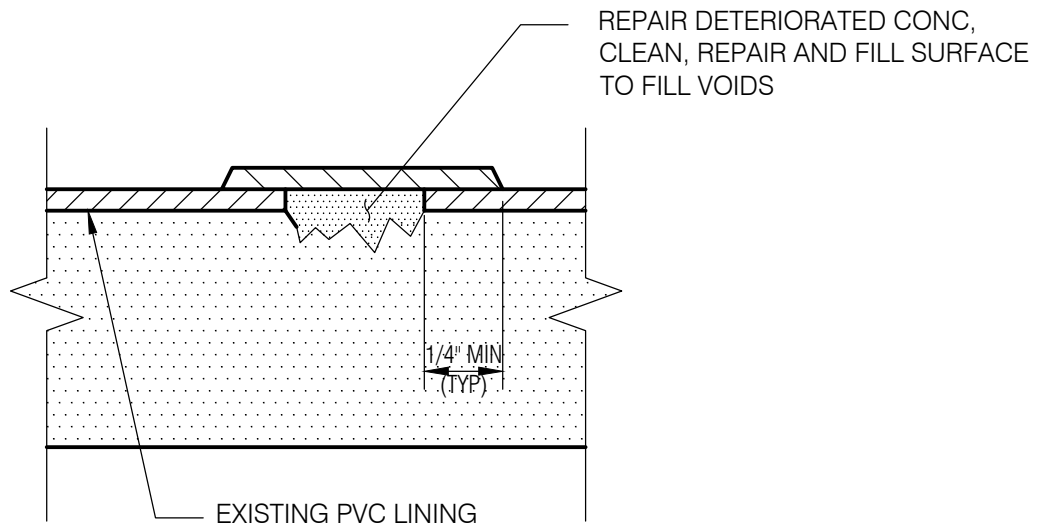

**SECTION A-A**

9/1/2022

N:\EOC\WD\EOC\WD-2021-002 Sewer Standards Update\300 Engineering\301 CAD\Plansets\S-23-3.dwg

NO.	APPROVED	DATE

EAST ORANGE COUNTY WATER DISTRICT ORANGE, CALIFORNIA	
APPROVED BY	<i>[Signature]</i>
GENERAL MANAGER	DATE 9/1/2022
DISTRICT ENGINEER	DATE 9/1/2022

**REHABILITATION OF PVC  
LINED MANHOLES**  
3 OF 4

NO SCALE
STANDARD DWG.
<b>S-23</b>

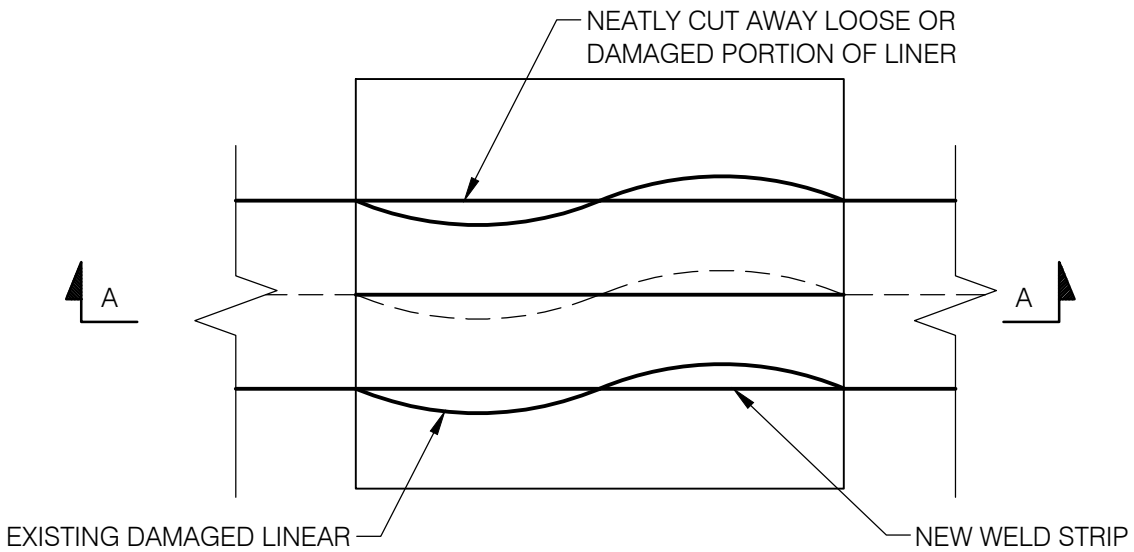

**DETAIL C**  
**PVC WELD STRIP REPAIR**

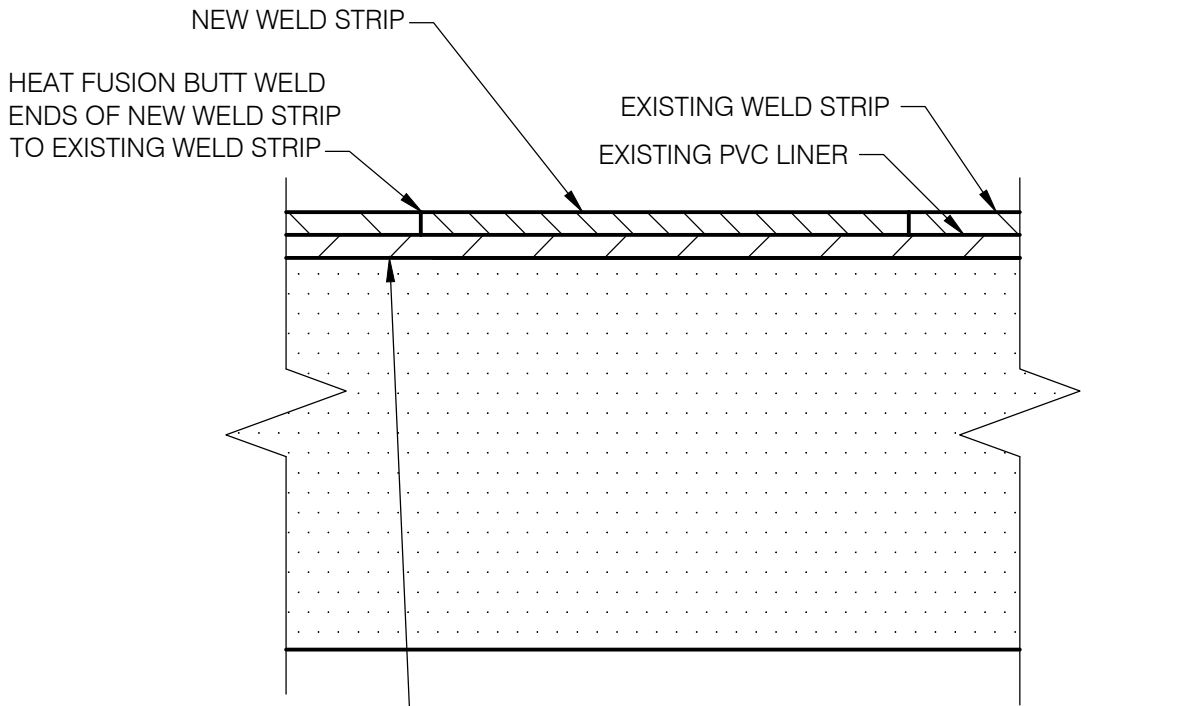

FIELD INSPECT PVC LINER BELOW DETERIORATED WELD STRIP FOR DETERIORATION AND REPAIR PER DETAIL 3 OR 4 AS APPROPRIATE. IF EVIDENCE OF INFILTRATION IS OBSERVED AT JOINTS, SEAL WITH HYDROPHILIC GROUT AND SEAL INJECTION HOLE(S) PER DETAIL 3 ON THIS SHEET

**SECTION A-A**

9/1/2022  
N:\ECC\WID\EOC\WD-2021-002 Sewer Standards Update\300 Engineering\301 CAD\Plansets\S-23-4.dwg

			EAST ORANGE COUNTY WATER DISTRICT ORANGE, CALIFORNIA	REHABILITATION OF PVC LINED MANHOLES 4 OF 4	NO SCALE
			APPROVED BY <i>[Signature]</i> 9/1/2022		STANDARD DWG.
			GENERAL MANAGER _____ DATE _____		<b>S-23</b>
NO.	APPROVED	DATE	DISTRICT ENGINEER <i>[Signature]</i> 9/1/2022		

9/1/2022

N:\ECC\DWG\ECOCWD-2021-002 Sewer Standards Update\300 Engineering\301 CAD\Plansets\S-24.dwg

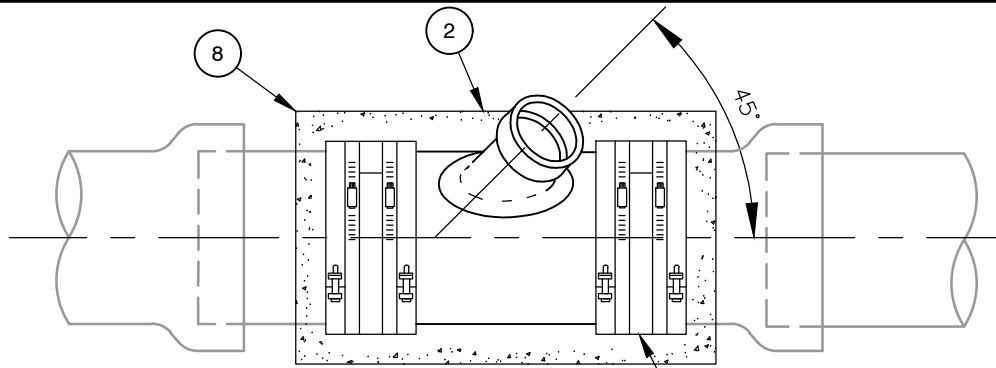

**VCP CUT-IN WYE**

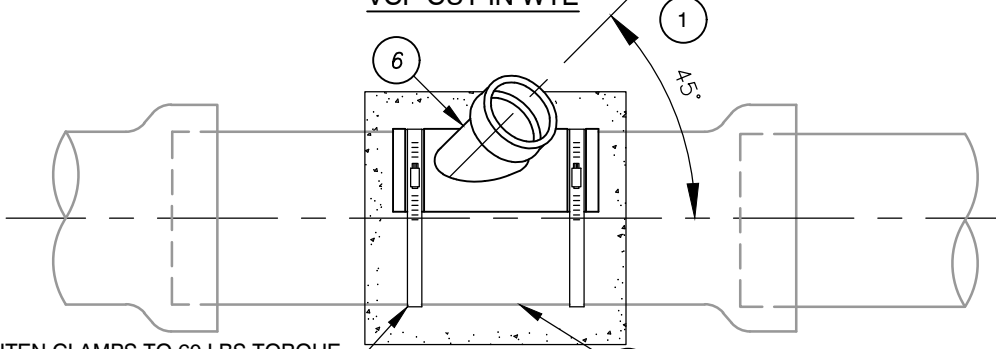

TIGHTEN CLAMPS TO 60 LBS TORQUE

**VCP SADDLE**

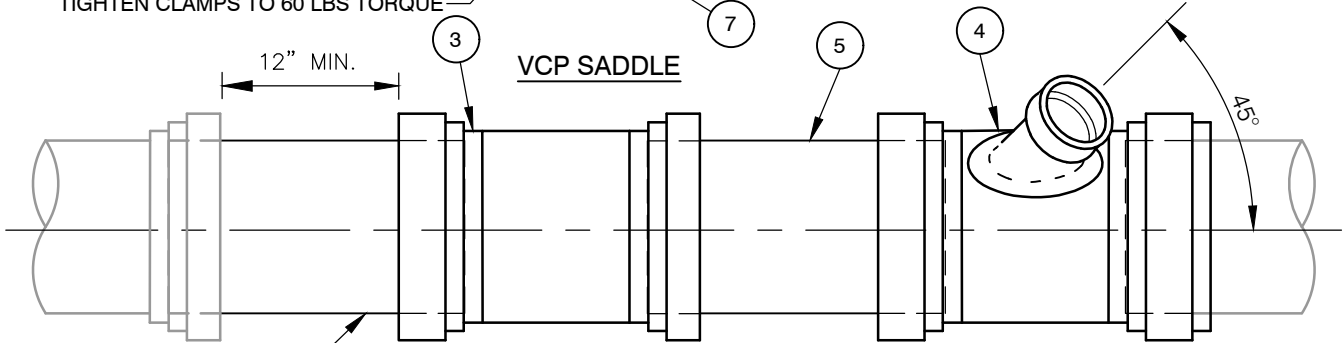

**PVC CUT-IN WYE**

**ITEM MATERIALS**

- 1 — BANDED RUBBER COUPLING WITH OUTSIDE TYPE 316 STAINLESS STEEL SHEAR RING.
- 2 — VCP WYE FITTING.
- 3 — GASKETED PVC PIPE COUPLING, REPAIR STYLE.
- 4 — GASKETED PVC WYE FITTING.
- 5 — SDR-35 PVC PIPE (PUP), MIN. LENGTH: 12".
- 6 — VCP TAP SADDLE WITH 316 STAINLESS STEEL SLIP LOCK CLAMP
- 7 — VCP MAIN
- 8 — 560-C-3250 CLASS A CONCRETE ENCASMENT

**NOTES:**

1. WHEN 12" MIN. SPACE BETWEEN EDGE OF COUPLING AND BELL CANNOT BE PROVIDED, CUT-OUT NEAREST BELL JOINT AND INSERT PLAIN-END PIPE.
2. ALL DEBRIS SHALL BE KEPT OUT OF THE SEWER. THE PIPE REACH CUT-INTO SHALL BE CLEANED AND BALLED, IF NECESSARY, AS DIRECTED BY THE DISTRICT REPRESENTATIVE.
3. DAMAGED PIPE SHALL BE REPLACED AS DIRECTED BY THE DISTRICT REPRESENTATIVE.
4. SADDLE-TYPE CONNECTIONS SHALL ONLY BE USED FOR SPECIAL SITUATIONS, AND SHALL NOT BE CONSTRUCTED WITHOUT PRIOR DISTRICT APPROVAL. NO BREAK INS ALLOWED, PIPE SHALL BE CORED.
5. 8" AND LARGER DIA. LATERALS SHALL BE CONNECTED TO MAIN LINE VIA MANHOLE ONLY
6. WYE'S MATERIAL SHOULD MATCH THE MAIN PIPE.

NO.	APPROVED	DATE

EAST ORANGE COUNTY WATER DISTRICT ORANGE, CALIFORNIA	
APPROVED BY	9/1/2022
GENERAL MANAGER	DATE
DISTRICT ENGINEER	DATE

**CUT IN WYE CONNECTIONS**

NO SCALE  
STANDARD DWG.  
**S-24**

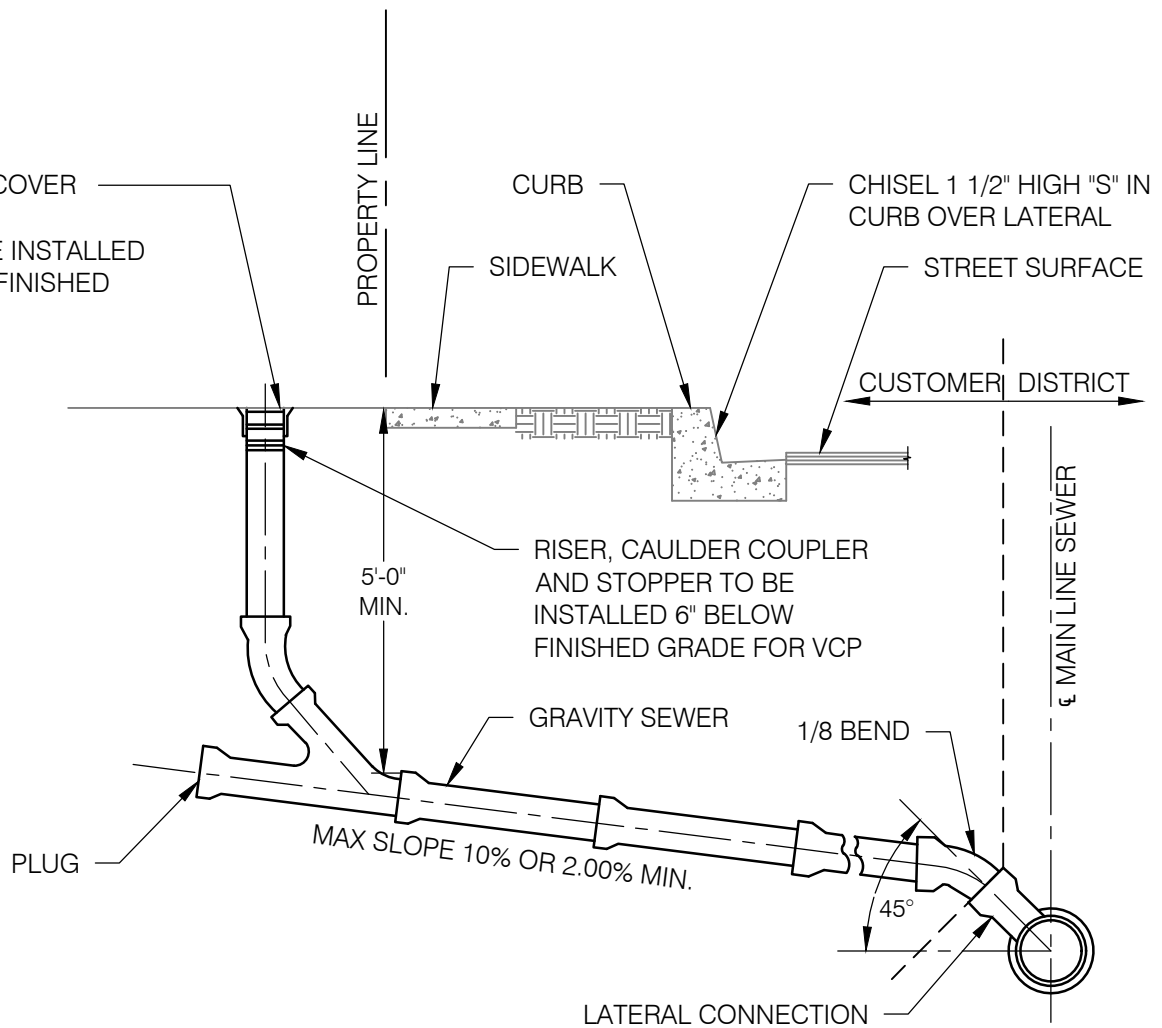

**NOTES:**

1. FOR SLOPE OTHER THAN SHOWN ON THE PLAN, APPROVAL IS REQUIRED BY ENGINEER.
2. THE LATERAL SHALL BE BEDDED THE SAME AS THE MAINLINE SEWER. SEE STD, DRAWING S-1.
3. FOR SEWER CLEANOUT RISER, USE PIPE OF THE SAME DIAMETER AND MATERIAL USED IN THE ADJOINING SEWER LINE.
4. SINGLE FAMILY RESIDENCES SHALL HAVE 4" DIAMETER SEWER LATERALS. 6" OR LARGER LATERAL WILL BE REQUIRED FOR MULTIPLE SINGLE FAMILY RESIDENCE CONNECTIONS INTO A COMMON LATERAL
5. WHERE DIRECTED BY THE ENGINEER, THE CLEANOUT SHALL BE INSTALLED ON THE PUBLIC PROPERTY SIDE OF THE PROPERTY LINE WITHIN A 12" x 12" x 6" DEEP CONCRETE BOX.

9/1/2022

N:\ECC\DWG\ECC\2021-002 Sewer Standards Update\300 Engineering\301 CAD\Plansets\S-25.dwg

		EAST ORANGE COUNTY WATER DISTRICT ORANGE, CALIFORNIA		<b>HOUSE LATERAL CONNECTION TYPICAL</b>		NO SCALE	
		APPROVED BY <i>[Signature]</i> 9/1/2022				STANDARD DWG.	
		GENERAL MANAGER _____ DATE		<b>S-25</b>			
NO.		APPROVED	DATE			DISTRICT ENGINEER <i>[Signature]</i> 9/1/2022	

EXISTING FINISH GRADE

REMOVE MANHOLE FRAME AND COVER, AND CONCRETE RING. REMOVE MANHOLE CONE AND SECTION PER PERMIT REQUIREMENTS.

EXISTING MANHOLE RINGS, BASE AND PIPE TO REMAIN

FILL VOID WITH SAND/CEMENT SLURRY

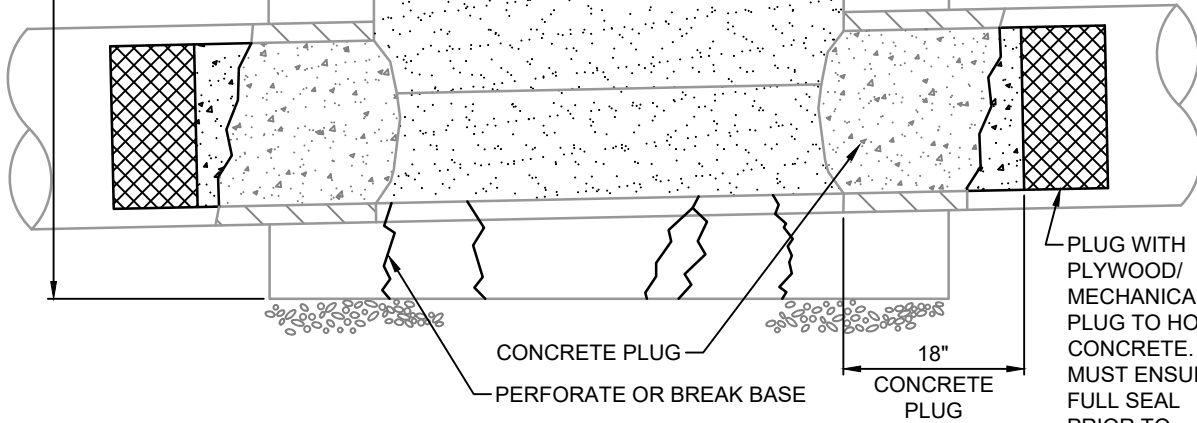

PLUG WITH PLYWOOD/MECHANICAL PLUG TO HOLD CONCRETE. MUST ENSURE FULL SEAL PRIOR TO POURING CONCRETE

NOTES:

1. ALL SALVAGED MATERIAL BECOMES THE PROPERTY OF EOCWD.
2. FILL 18" OF ABANDONED SEWER MAIN WITH CONCRETE OR PRESSURE GROUTING.
3. BACKFILL TRENCH ZONE WITH NATIVE EARTH MATERIAL. BACKFILL SHALL BE COMPACTED TO MINIMUM 90% RELATIVE COMPACTION

9/1/2022

N:\EOCWD\EOCWD-2021-002 Sewer Standards Update\300 Engineering\301 CAD\Plansets\S-26-1.dwg

NO.	APPROVED	DATE

EAST ORANGE COUNTY WATER DISTRICT  
ORANGE, CALIFORNIA  
APPROVED BY *[Signature]* 9/1/2022  
GENERAL MANAGER DATE  
DISTRICT ENGINEER *[Signature]* 9/1/2022  
DATE

EXISTING MANHOLE  
ABANDONMENT  
(ABANDONED SEWER LINE )  
1 OF 2

NO SCALE  
STANDARD DWG.  
**S-26**

9/1/2022

N:\EOCWD\EOCWD-2021-002 Sewer Standards Update\300 Engineering\301 CAD\Plansets\S-26-2.dwg

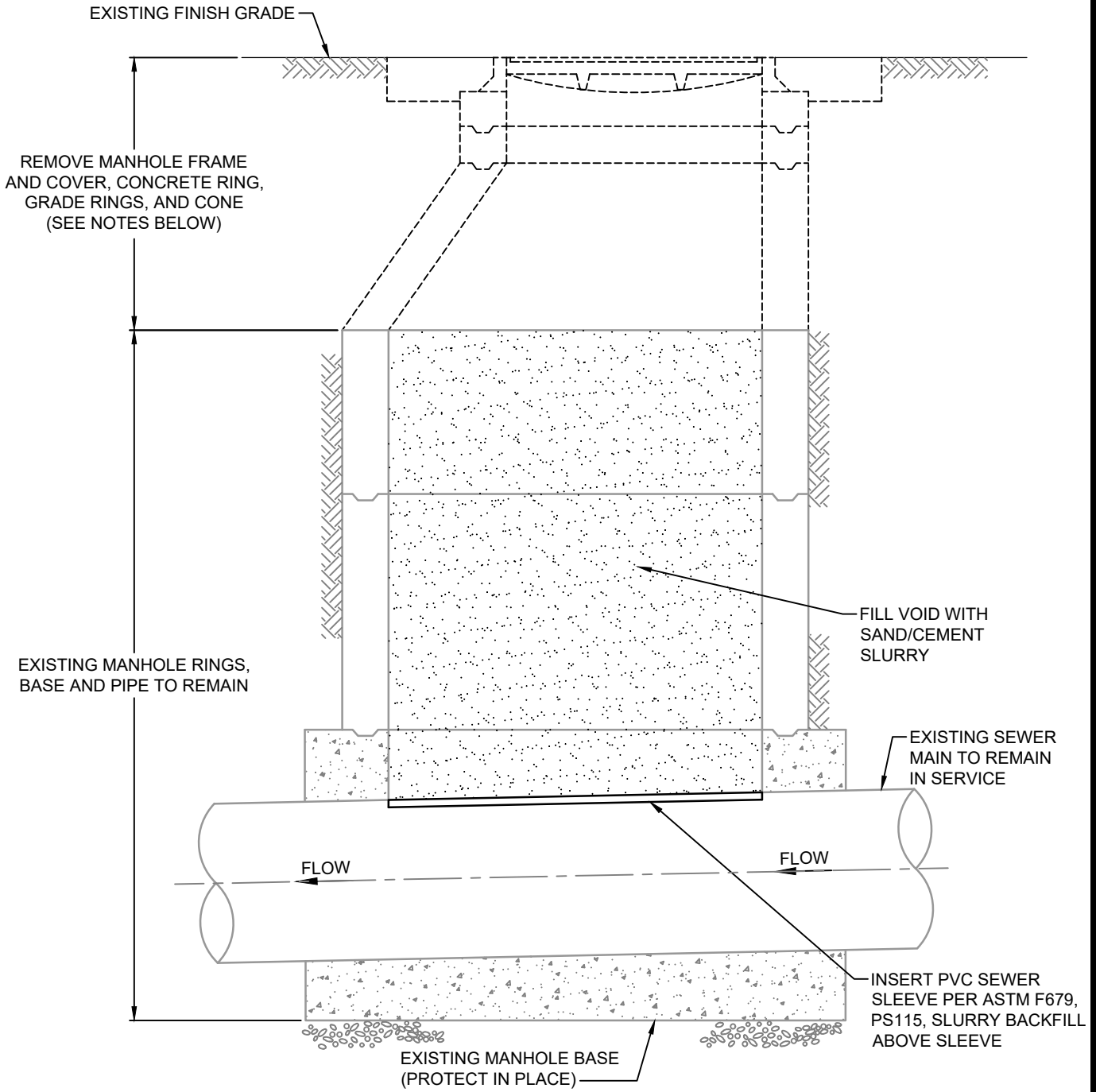

**NOTES:**

1. FIELD MEASURE MANHOLE CHANNEL AND DETERMINE NEEDED SLEEVE DIMENSIONS PRIOR TO INSTALLATION.
2. INSTALL SLEEVE INSIDE FLOW CHANNEL, ALIGN INVERTS OF SLEEVE AND EXISTING SEWER PIPE INSIDE MANHOLE FOR A CONTINUOUS GRADE.
3. AVOID VERTICAL AND HORIZONTAL DISPLACEMENT OF SLEEVE DURING BACKFILLING.
4. DO NOT ALLOW SLURRY TO ENTER INSIDE OF SEWER PIPE.
5. ALL SALVAGE MATERIAL BECOMES PROPERTY OF EOCWD.
6. BACKFILL TRENCH ZONE WITH NATIVE EARTH MATERIAL. BACKFILL SHALL BE COMPACTED TO MINIMUM 90% RELATIVE COMPACTION.

NO.	APPROVED	DATE

EAST ORANGE COUNTY WATER DISTRICT  
ORANGE, CALIFORNIA

APPROVED BY *[Signature]* 9/1/2022  
DATE

GENERAL MANAGER *[Signature]* 9/1/2022  
DATE

DISTRICT ENGINEER *[Signature]* 9/1/2022  
DATE

**EXISTING MANHOLE  
ABANDONMENT  
(SEWER LINE IN SERVICE )  
2 OF 2**

NO SCALE  
STANDARD DWG.  
**S-26**